



# OWNER'S MANUAL

AXOPAR 29 XC CROSS CABIN

MODEL YEAR 2024

**AXOPAR** 

# Table of Contents

1 Introduction.....	5
1.1 Purpose of this manual.....	5
1.2 Safety symbols.....	5
1.3 Document conventions.....	6
1.4 Copyright.....	6
1.5 Disclaimer .....	6
1.6 Warranty.....	7
<b>2 Safety.....</b>	<b>8</b>
2.1 Safe and responsible boat operation.....	8
2.2 Safety diagram.....	10
2.3 Fire protection and control.....	10
2.3.1 Fire control equipment.....	11
2.3.2 Boat owners' and users' responsibilities.....	11
2.3.3 Checklist: Fire in the engine.....	12
2.3.4 Checklist: After fire.....	12
2.4 Carbon monoxide.....	12
2.5 Carbon monoxide monitor.....	13
2.6 Smoke alarm.....	14
2.7 Life raft.....	15
2.8 Safety labels on board.....	15
<b>3 Product overview.....</b>	<b>23</b>
3.1 Purpose of use.....	23
3.2 Identification.....	23
3.3 Builder's plate.....	24
3.4 CE certification.....	24
3.5 Dimensions and weight.....	25
3.6 Boat layout.....	27
<b>4 Product description.....</b>	<b>29</b>
4.1 Stability and buoyancy.....	29
4.1.1 Self-draining systems.....	29
4.1.2 Openings in the hull and deck.....	30
4.1.3 Bilge system.....	33
4.1.3.1 Bilge pumps.....	34
4.2 Technical systems.....	34
4.2.1 Electrical system.....	34
4.2.2 12 V system.....	35

4.2.3 Main switches.....	36
4.2.4 Direct supply fuses.....	37
4.2.5 Fuses.....	37
4.2.6 Heavy duty fuses.....	38
4.2.7 Batteries.....	39
4.2.7.1 Charging the batteries.....	39
4.2.7.2 Winter storage .....	39
4.2.7.3 Cleaning the batteries .....	39
4.2.8 110/230 V system.....	40
4.2.9 Fuel system.....	41
4.2.9.1 Refueling the boat.....	42
4.2.9.2 Maintaining the fuel system.....	43
4.3 Optional equipment.....	43
4.3.1 Fresh water system.....	43
4.3.2 Septic system.....	46
4.3.2.1 Toilet seat.....	46
4.3.2.2 Septic tank.....	47
4.3.3 Heating system.....	47
4.3.4 Navigation system.....	48
4.3.4.1 VHF equipment.....	48
4.3.5 Bow thruster.....	48
4.3.6 Anchor windlass.....	49
4.3.7 Roof racks.....	50
<b>5 Transportation.....</b>	<b>51</b>
5.1 Lifting the boat.....	51
5.2 Transporting and storing the boat.....	52
<b>6 Operation.....</b>	<b>54</b>
6.1 Handling devices.....	54
6.1.1 Steering console.....	54
6.1.2 Steering console switch panel.....	56
6.1.3 Windscreen wipers .....	56
6.1.4 Steering system.....	56
6.1.4.1 Checking and topping up oil .....	56
6.1.4.2 Steering maintenance .....	57
6.1.5 Throttle lever.....	57
6.1.5.1 Trim and tilt.....	57
6.1.6 Starting the engine.....	57
6.2 Swivel seat - Driver and passenger seats.....	58
6.3 Inspecting the boat.....	59
6.3.1 Checklist: Regular inspection before leaving harbor.....	59

6.3.2 Checklist: After using the boat..... 60

6.3.3 Checklist: After grounding..... 60

6.4 Handling the boat..... 61

6.4.1 Checklist: Boat handling before leaving harbor ..... 61

6.4.2 Leaving the jetty ..... 61

6.4.3 Driving the boat..... 62

6.4.3.1 Dead man's switch ..... 62

6.4.3.2 Driving at high speed..... 62

6.4.3.3 Driving in rough seas..... 63

6.4.3.4 Maneuvering in narrow channels..... 63

6.4.4 Visibility from steering position..... 64

6.4.5 Using the trim tabs..... 64

6.5 Preventing falling overboard..... 65

6.6 Anchoring, docking and mooring..... 66

6.6.1 Fastening points..... 66

6.6.2 Docking..... 66

6.6.3 Checklist: Before anchoring ..... 67

6.6.4 Towing and mooring..... 67

7 Maintenance..... 68

7.1 Cleaning and maintaining the gelcoat surface..... 68

7.2 Antifouling..... 70

7.3 Maintaining the interiors..... 71

7.3.1 Wooden interiors..... 71

7.3.2 Plastic and painted surfaces..... 71

7.3.3 Fabrics..... 71

7.3.4 Doors and hatches..... 71

7.4 Maintaining the cover..... 71

7.4.1 Cleaning the cover..... 72

7.5 Protecting underwater metal parts..... 72

7.6 Preventing corrosion..... 73

7.7 Preventing frost damage..... 73

7.8 Checklist: Before winter lay-up..... 73

7.9 Checklist: Before launching..... 74

7.10 Corrective maintenance..... 74

7.10.1 Deposits..... 74

7.10.2 Scratches and nicks..... 74

7.10.3 Stains..... 75

7.10.4 Deep marks, gouges and holes..... 75

8 Environment..... 76

8.1 Requirements for North America..... 76

---

9 Appendix I: Checklists.....	78
9.1 Checklist: Fire in the engine.....	78
9.2 Checklist: After fire.....	78
9.3 Checklist: After grounding.....	78
9.4 Checklist: Regular inspection before leaving harbor.....	79
9.5 Checklist: After using the boat.....	80
9.6 Checklist: Boat handling before leaving harbor .....	80
9.7 Checklist: Before anchoring .....	80
9.8 Checklist: Before winter lay-up.....	81
9.9 Checklist: Before launching.....	81
10 Appendix II: Fuel system.....	83
10.1 Fuel system: EU.....	83
10.2 Fuel system: USA (EPA).....	84
11 Appendix III: Electrical diagrams.....	85
12 Appendix IV: AIS Decontamination – North America.....	86
13 Appendix V: Strapping and transport.....	87

# 1 Introduction

## 1.1 Purpose of this manual

This owner's manual contains important information and instructions for using your boat.

In this owner's manual you can find important information that help you handle and maintain your boat. The manual contains detailed information about the boat and the systems installed, and general information about handling and taking care of the boat. The latest version of the manual is available in electronic format at the manufacturer's website.

Read the manual carefully and familiarize yourself with your boat before you start to use it. Also ensure that the anticipated wind and wave conditions correspond to the design category of your boat, and that you and your crew are able to handle the boat in these conditions.



This owner's manual is not a substitute for boating safety skills or good seamanship.

If this is your first boat or if this boat type is new to you, ensure you can handle the boat before you set out for the first time.

For information about local sea schools and approved instructors, please ask your boat dealer, the local boat clubs and national motorboat or yacht federations for advice. They can also provide information on specific local regulations on issues such as a driving licence or authorization, registration, insurance, and safety equipment.

This owner's manual is not a detailed maintenance or troubleshooting guide. If problems occur, contact the boat manufacturer or its local representative. When you are in need of maintenance or repair and alteration work, always turn to competent and trained professionals. Changes that can affect the boat's security features must be assessed, carried out and documented by competent professionals. The boat manufacturer cannot be held responsible for unauthorized modifications. Every change to the boat's center of gravity (from highly mounted heavy equipment or a new engine type etc.) significantly affects the stability, trim and performance of the boat.

Keep this manual in a safe place and pass it on to the new owner if you sell your boat. If the manual is mislaid or destroyed, a copy can be ordered from your dealer or downloaded from the manufacturer's website.

See the purchase agreement or order for the scope of your purchase. In case something does not work satisfactorily with your boat or its equipment, you can check the service documents for possible service and repair measures. If uncertain, always contact your dealer.

## 1.2 Safety symbols

This owner's manual contains danger, warning, caution and notice statements informing the user or authorized service representatives of any potential harm to the product or person.

Hazard is defined as a source of potential injury to a person.

All abnormal use is forbidden, including disregarding information on safety.

 **DANGER** indicates an imminently hazardous situation which, if not avoided, **will result in death or serious injury**.

 **WARNING** indicates a potentially hazardous situation which, if not avoided, **could result in death or serious injury**.

 **CAUTION** indicates a potentially hazardous situation which, if not avoided, **might result in minor or moderate injury**.

 **NOTICE** indicates a potential situation which, if not avoided, **might result in property damage or in an undesirable result or state**.



The information icon calls attention to information that clarifies or simplifies a procedure.

## 1.3 Document conventions

### Units

This manual uses SI units in accordance with ISO 1000. In some cases, other units may have been used alongside.

An exception is the wind velocity, which in the Recreational Boat Directive is given in the Beaufort Scale.

### Terminology

In this manual, the right side of the hull is referred to as starboard and the left side as port.

## 1.4 Copyright

Copyright ©2024 Axopar Boats. All rights reserved.

This Owner's Manual is protected by copyright controlled by Axopar Boats. This manual cannot be wholly or partly reproduced without prior written authorization by Axopar Boats. This material also contains confidential information, which may not be disclosed to others without the prior written consent of Axopar Boats.

## 1.5 Disclaimer

The material in this manual is for information purposes only.

Axopar Boats reserves the right to change the products without prior notice to improve reliability, function, design or other characteristics of the products. Axopar Boats assumes no liability for any damages, losses, costs or expenses arising out of or relating to the use of this manual or the products described herein.

Axopar Boats makes no representations and warranties with respect to this manual, either express or implied, including, but not limited to, the implied warranties of merchantability and fitness for a particular purpose.

## 1.6 Warranty

The Limited Warranty for the boat and the relevant contact information are enclosed as a separate document.

For any warranty claims, please contact your Axopar dealer mentioned on the cover page.



## 2 Safety

### ⚠ WARNING

The boat owner is responsible for making sure that the safety equipment on the boat meets the rules and regulations of the local authorities.

- Keep the necessary safety equipment up to date and on the boat at all times.

Check the preferred location of the major safety equipment in the section **Safety diagram**.

### ⚠ WARNING

Overloading the boat can damage the engine, even when shut off.

- When loading the boat, never exceed the maximum recommended load of the boat shown in the builder's plate.
- Always load the boat carefully and distribute loads appropriately to maintain design trim.
- Avoid placing heavy equipment or material high up in the boat.

The liquids in the built-in tanks are not included in the maximum load shown on the builder's plate.

### ⚠ WARNING

When out on the water, always use the seats intended for the passengers.

Do not exceed the maximum number of persons allowed in the boat, shown in the builder's plate.

The total weight of the persons on board and their personal luggage must never exceed the maximum load of the boat shown in the builder's plate.

### ⚠ CAUTION

Risk of personal injury and risk of damage to the roof or roof structures.

Do not place or attach any load or equipment on the roof or to the roof structures if there is no specific roof rack.

It is forbidden to enter the roof or dangle from the roof structures.

## 2.1 Safe and responsible boat operation

Please familiarize yourself to these safety aspects before using the boat. The person controlling the boat is in charge of the safety of all the passengers as well as other seafarers.

Neglecting these safety rules might lead to serious injury or death.

- Anyone who controls the boat must be competent to operate a boat of this type and size.
- The boat must not be controlled by an unqualified operator or by an operator under the influence of alcohol, drugs or other substance which impair judgement.
- The boat must always be operated at speeds that will not put people or property in danger.
- The captain must constantly be aware of conditions surrounding the boat when underway and especially before sharp turns.

- In challenging conditions such as rough water and winds, impaired visibility, and congested waterways; reduce speed, use appropriate navigation equipment and lights, and use a lookout to identify possible hazards.
- Pay attention to your wake. It can endanger smaller boats or damage moored boats or other property. You are responsible for damage caused by your wake.
- Only allow passengers to ride in areas that do not pose a hazard to themselves or the boat.
- Do not allow passengers to ride on aft folding seats, aft fender boxes or gunwales.
- Passengers must remain seated while the boat is moving.
- Use of alcohol, drugs, or other judgment-impairing substances poses a serious threat to yourself and others. The boat operator is responsible for the behavior of people on board.
- For every passenger on board, the boat must carry one wearable personal flotation device (PFD).

**⚠ WARNING****Speed hazard**

This is a high-performance vessel; the speed of the craft needs to be adapted to the environment. To ensure your passengers' safety and comfort, avoid sharp turns in speeds exceeding 40 knots. Never operate your boat at speeds which exceed your ability to react to surprising and unpredictable situations. The captain is always responsible for operating the vessel in a safe way.

**⚠ WARNING**

Never operate a boat at a speed at which you do not feel comfortable.

**⚠ DANGER****Slipping hazard**

Deck might be slippery when wet, even on non-skid areas. Be extremely cautious on slippery surfaces and wear suitable footwear.

**⚠ DANGER**

Do not go out boating in severe weather conditions as this might lead to serious injuries or death. Always get back to shore before the weather turns bad.

## 2.2 Safety diagram

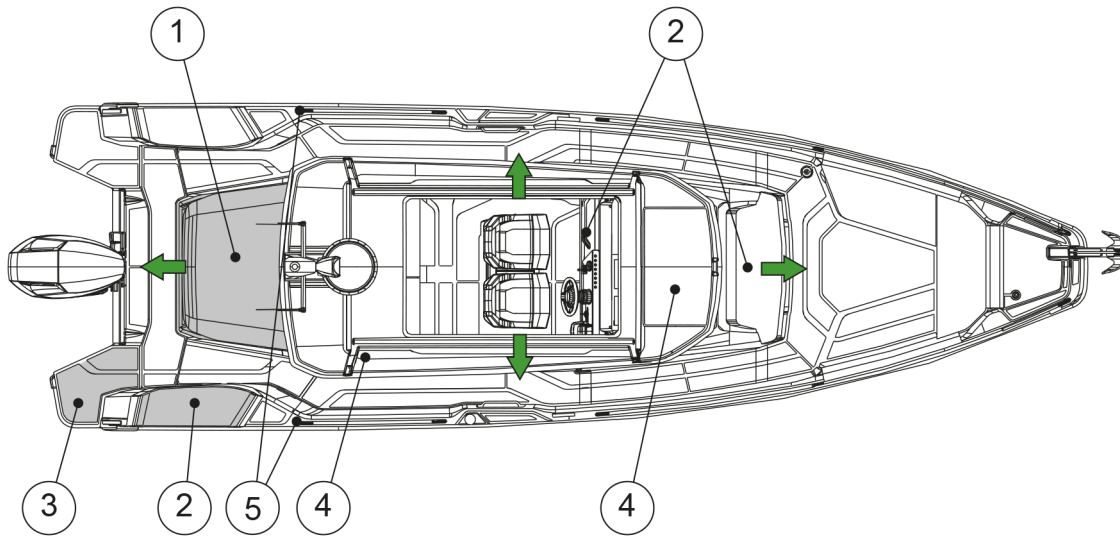

- (1) Life raft storage
- (2) Fire extinguisher
- (3) Swim ladder
- (4) CO monitor and smoke alarm
- (5) Hooking points for safety harness
- Exit

## 2.3 Fire protection and control

The most common fire sources are the engine and the stove. If there is a fire in the boat, it may result in an explosion.

**⚠ WARNING**

Fire usually spreads very fast — be quick to extinguish the fire with the fire extinguisher on the boat!

See the section **Safety diagram** for the exact location of the fire extinguisher(s).

**If the fire starts to get out of control, leave the burning boat to save lives.**

**⚠ WARNING**

Always put down the fire by depriving the fire of oxygen.

Do not use water!

Using water in fire involving flammable liquids can spread the liquid and make the fire worse.

**⚠ WARNING**

If the fire reaches the fuel containers, an explosion may occur and cause a large area around the boat to burn.

- Keep the bilge clean and check it regularly for fuel and gas fumes or fuel and oil leaks.
- Do not hang curtains or other flammable material near or above any equipment with naked flames.
- Never leave the boat unattended when the heater is switched on.
- Never refuel or replace gas containers when the engines are running.
- Never smoke when handling fuel or gas.
- Never block evacuation routes or emergency exits.
- Never block access to safety equipment such as fuel valves or main power switches.
- Never block access to fire extinguishers, visible or concealed.
- Never modify the boat's systems (especially electrical, fuel or gas systems).

### 2.3.1 Fire control equipment

Check the exact locations of the fire control equipment in the section **Safety diagram**.

#### Fire extinguishers

You must fit the boat with hand-held fire extinguishers. The fire ratings of the fire extinguishers must be at least as follows:

- Starboard fender box: 8A/89B (USCG: 5-B)
- Near driver's seat, under feet support, multicabin and an optional aft cabin: 8A/68B (USCG: 5-B).

Check the exact locations of the fire extinguishers in the section **Safety diagram**.



The fire extinguishers are not included in the manufacturer's delivery. Before using the boat, it must be furnished with fire extinguishers.

#### Fire blanket

A fire blanket is ideal for putting out small fires and also one of the best options if a person's clothes catch fire.

- Keep a fire blanket onboard in an easily accessible place.

### 2.3.2 Boat owners' and users' responsibilities

It is your responsibility as the boat owner and user to ensure that the fire control equipment is accessible at all times.

- Check the fire extinguishing equipment regularly at the intervals specified for the equipment.
- Replace equipment with expired date immediately with equivalent or better equipment.
- Advise the crew and guests of the location and instructions for use of the fire control equipment, and the location of evacuation routes and emergency exits.

### 2.3.3 Checklist: Fire in the engine

- Stop the engine.
- Steer the boat up against the wind, if possible.
- Make sure all passengers have life jackets.
- If necessary:
  - Evacuate the passengers.
  - Call for sea rescue.
- Extinguish the fire.
- Wait until fully certain that the fire has been extinguished before opening the engine cover.  
Carefully open the engine cover and be prepared to use the handheld fire extinguisher if necessary for post-fire extinguishing.
- Put out possible smoldering fires with water.

### 2.3.4 Checklist: After fire

- Open doors and windows for better ventilation.
- Inspect the boat and its equipment, and repair any damages.
- Contact local authorities, if needed.
- Make sure that the fire extinguishing equipment is refilled or replaced after use.

## 2.4 Carbon monoxide

**⚠ WARNING**

Carbon monoxide (CO) is colorless, odorless, tasteless, and extremely dangerous gas.

All engines, generators, and fuel burning appliances produce CO as exhaust.

Prolonged exposure to low concentrations or very quick exposure to high concentrations may cause brain damage or death.

Open all doors, curtains, windows, and hatches to let fresh air circulate when running an engine or generator or burning any fuel while the boat is anchored, moored or docked.

If you can smell engine or generator exhaust, you are inhaling CO. CO can also be present without the smell of exhaust fumes.

**If the CO alarm is activated, make sure all persons onboard exit the closed spaces.**

- If exhaust fumes are detected or if CO accumulation is suspected on the boat, take immediate action to ventilate these fumes.
- Turn off all engines and generators.
- Open all hatches, windows and ports to ventilate.

Changing course and speed to place the boat heading into the wind can improve ventilation.

Symptoms of carbon monoxide poisoning are dizziness, ears ringing, headache, nausea and unconsciousness. A poisoning victim's skin often turns cherry red.

Because the carbon monoxide gas is odorless, colorless and tasteless, it is unlikely to be noticed until a person is affected.

- **If CO poisoning is suspected, have the victim breath fresh air deeply.**
- **If breathing stops, resuscitate.**
- A victim often revives, but then relapses because organs are damaged by the lack of oxygen.  
**Seek immediate medical attention.**

High levels of carbon monoxide may accumulate in the following ways:

- Blocking hull exhausts while operating at slow speed or if exhausts are submerged.
- Using canvas curtains.
- Winds blowing exhaust toward boat occupants.
- Operating engine or generator in a confined space.
- Operating with the bow high.

Dangerous concentrations of carbon monoxide are present if:

- the engine or generator exhaust systems leak
- insufficient fresh air is circulating where people are present
- fumes move from the rear of the boat into the cockpit and cabin area.

To minimize the danger of CO accumulation when the engine and generator are running or when using burning fuel applications:

- Be sure to have sufficient ventilation when using canvas or window-type side curtains when underway, anchored, moored or docked.
- Operate all burning fuel appliances, such as charcoal, propane, LPG, CNG or alcohol cooking devices, in areas where fresh air can circulate.

Do not use such devices where there is no noticeable air movement, especially in the cabin, when anchored, moored or docked.

- Do not idle the engine without moving the boat for more than 15 minutes at a time.
- Inspect the exhaust system regularly. See the manufacturer's manual for instructions.

## 2.5 Carbon monoxide monitor

There is a carbon monoxide monitor system in the boat.

The carbon monoxide monitors are located in all accommodation areas of the boat.

- With regular intervals, check that the monitor system is functioning. For instructions, see the equipment manufacturer's manual.
- It is not possible to turn the CO monitor off when the boat is in use.

See here the description of the audible and visual signals of the monitor.



Low battery voltage can trigger the carbon monoxide monitor to sound an alarm.

Operation	Audible Signal	Visual Signal
Normal	None	Green led flashes every minute
CO alarm	4 beeps, 5 seconds off - cycle repeats	Flashing red
Alarm malfunction	Beep every 30 seconds	Alternating red/green flash
End of life signal	Beep every 25-30 second	Red red green green flash sequence

## 2.6 Smoke alarm

Boat is equipped with smoke alarms.

Smoke alarm is battery powered. When the battery level reaches low level, the smoke alarm will start emitting low battery warning signal.

Smoke alarm may give false alarm if there is steam, condensation, or normal smoke or fumes in its vicinity.

The smoke alarm has a built-in hush or silence feature incorporated into the test button. This feature can be useful when unwanted alarm is caused by cooking or other non-hazardous sources trigger the alarm. Hush or silence feature temporarily silences the alarm and can be activated by pressing the test button for approximately 1 second. When hush or silence feature is activated, the alarm will enter dormant mode for 10-minute period with reduced sensitivity. Reduced sensitivity is indicated by red LED flashing every 10 seconds. After the period is over, the device will signal returning to normal sensitivity with two short beeps. If smoke density increases during hush or silence period, the device will automatically return to alarm mode.

Smoke alarms should be replaced at minimum every 5 years.

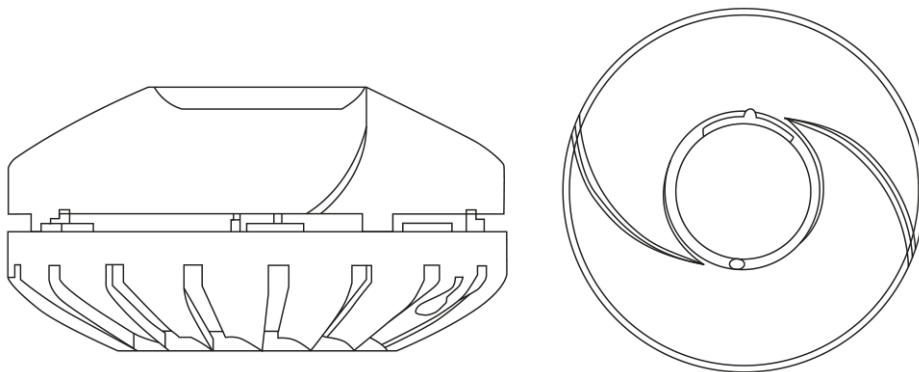

Figure 2.1 Smoke alarm

## 2.7 Life raft

The boat is not equipped with a life raft by the manufacturer.

### Storing a life raft

If you decide to acquire a life raft for your boat, stow it to the aft of the boat, so that it is easily accessible in case of emergency.

### Using the life raft

The life raft must be tied to the stern of the boat and prepared for use.

In an emergency, it is easiest and safest to board the life raft from the swimming deck. Switch off the engine before using the life raft.





Follow the life raft manufacturer's instructions.

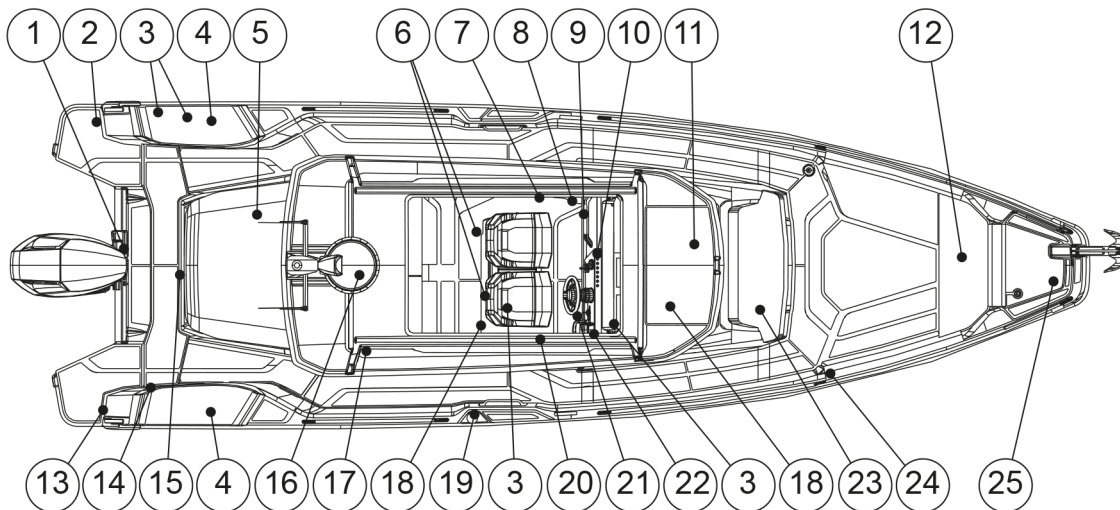

## 2.8 Safety labels on board

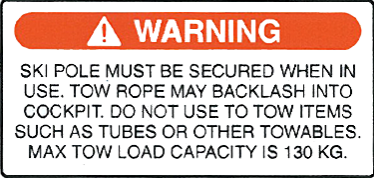
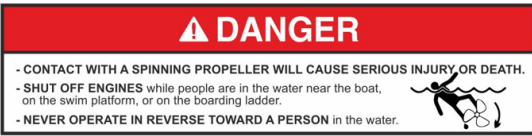

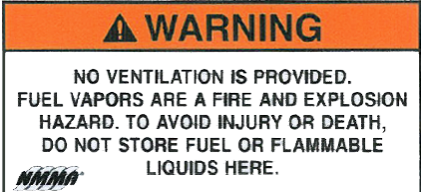

The following picture and table present the location and description of the safety labels on board.

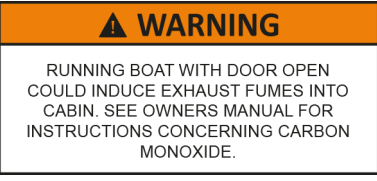

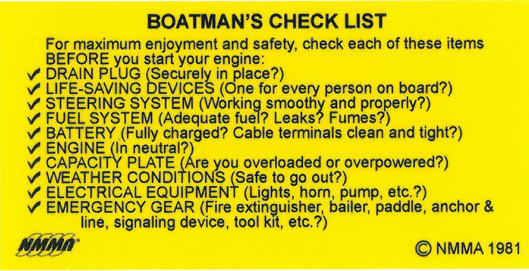

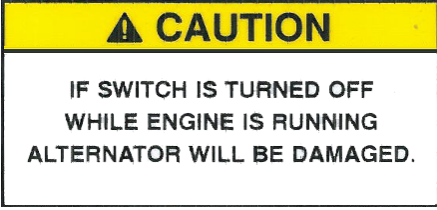
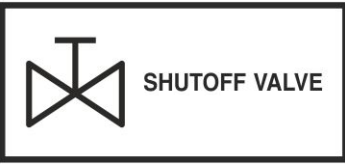





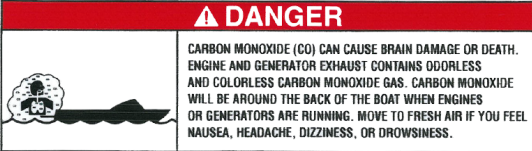

Position	Label	Description
1		<p><b>Warning</b></p> <p>Ski pole must be secured when in use. Tow rope may backlash into cockpit. Do not use to tow items such as tubes or other towables. Max tow load capacity is 130 kg.</p>
2		<p><b>Danger</b></p> <p>-Contact with a spinning propeller will cause serious injury or death.</p> <p>-Shut off engines while people are in the water near the boat, on the swim platform, or on the boarding ladder.</p> <p>-Never operate in reverse toward a person in the water.</p>
2	<p><b>DISCHARGE OF OIL PROHIBITED</b></p> <p>THE FEDERAL WATER POLLUTION CONTROL ACT PROHIBITS THE DISCHARGE OF OIL OR OILY WASTE INTO OR UPON THE NAVIGABLE WATERS OF THE UNITED STATES, OR THE WATERS OF THE CONTIGUOUS ZONE, OR WHICH MAY AFFECT NATURAL RESOURCES BELONGING TO, APPERTAINING TO, OR UNDER THE EXCLUSIVE MANAGMENT AUTHORITY OF THE UNITED STATES, IF SUCH DISCHARGE CAUSES A FILM OR DISCOLORATION OF THE SURFACE OF THE WATER OR CAUSES A SLUDGE OR EMULSION BENEATH THE SURFACE OF THE WATER. VIOLATORS ARE SUBJECT TO SUBSTANTIAL CIVIL PENALTIES AND/OR CRIMINAL SANCTIONS INCLUDING FINES AND IMPRISONMENT.</p> 	<p><b>Discharge of oil prohibited</b></p> <p>The federal water pollution control act prohibits the discharge of oil or oily waste into or upon the navigable waters of the United States, or the waters of the contiguous zone, or which may affect natural resources belonging to, appertaining to, or under the exclusive management authority of the Unites States, if such discharge causes a film or discoloration of the surfaces of the water or causes a sludge or emulsion beneath the surface of the water. Violators are subject to substantial civil penalties and/or criminal sanctions including fines and imprisonment.</p>
3		<p>Do not drink the water.</p>
4		<p><b>Warning</b></p> <p>No ventilation is provided. Fuel vapors are a fire and explosion hazard. To avoid injury and death, do not store fuel or flammable liquids here.</p>
5		<p><b>Caution</b></p> <p>If switch is turned off while engine is running the alternator will be damaged.</p>



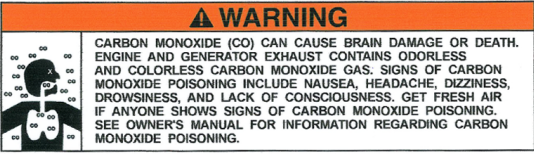
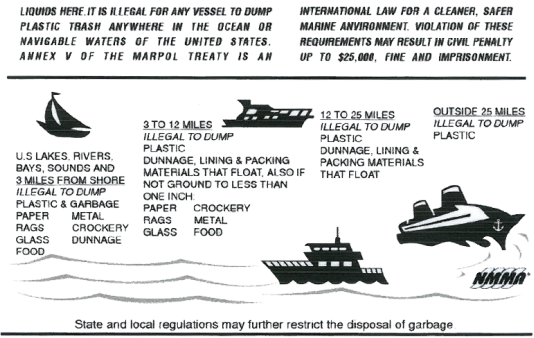
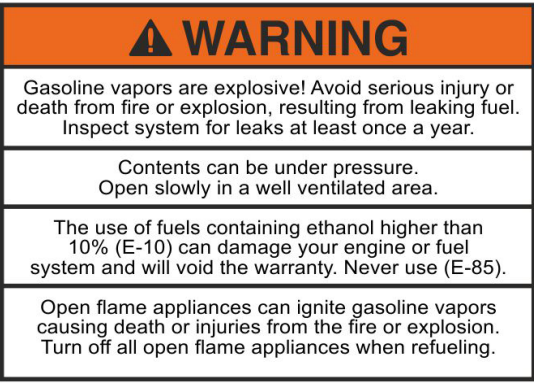

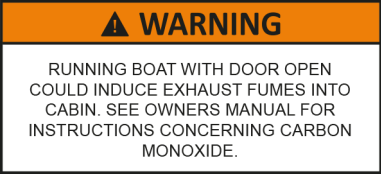
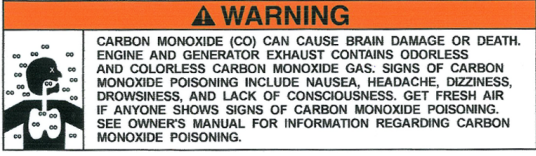

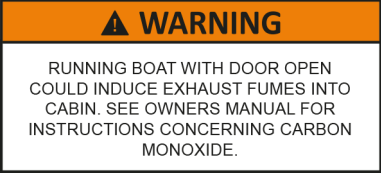
Position	Label	Description
6		<p><b>Warning</b></p> <p>Avoid serious injury or death. Unexpected seat rotation may cause ejection of occupant.</p> <p>Lock swivel when speed exceeds 5 mph.</p>
7		<p><b>Warning</b></p> <p>Running boat with door open could induce exhaust fumes into the cabin. See the owner's manual for instructions concerning carbon monoxide.</p>
7		<p><b>Warning</b></p> <p>Keep shut while underway.</p>
8		<p><b>Boatman's checklist</b></p> <p>For maximum enjoyment and safety, check each of these items before you start your engine:</p> <ul style="list-style-type: none"> <li>- Drain plug (Securely in place?)</li> <li>- Life-saving devices (One for every person on board?)</li> <li>- Steering system (Working smoothly and properly?)</li> <li>- Fuel system (Adequate fuel? Leaks? Fumes?)</li> <li>- Battery (Fully charged? Cable terminals clean and tight?)</li> <li>- Engine (In neutral?)</li> <li>- Capacity plate (Are you overloaded or overpowered?)</li> <li>- Electrical equipment (Lights, horn, pump, etc?)</li> <li>- Emergency gear (Fire extinguisher, bailer, paddle, anchor &amp; line, signaling device, tool kit, etc.?)</li> </ul>

Position	Label	Description
9		<p><b>Caution</b></p> <p>If switch is turned off while engine is running the alternator will be damaged.</p>
10	<p><b>WARNING</b> WATERTIGHT CLOSURE KEEP SHUT WHEN UNDER WAY</p>	<p><b>Warning</b></p> <p>Watertight closure. Keep shut when under way.</p>
11		<p>Shutoff valve</p>
12		<p>Pay attention to the warnings and read the manual.</p>
12		<p><b>Warning</b></p> <p>Electrical shock and fire hazard. Failure to follow these instructions may result in injury or death.</p> <p>(1) Turn off the boat's shore power connection switch before connecting or disconnecting the shore power cable.</p> <p>(2) Connect shore power cable at the boat first.</p> <p>(3) If polarity-warning indicator is activated, immediately disconnect cable.</p> <p>(4) Disconnect shore power cable at shore outlet first.</p> <p>(5) Close shore power inlet cover tightly.</p> <p>Do not alter shore power cable connectors.</p>
12		<p><b>Warning</b></p> <p>No ventilation is provided. Fuel vapors are a fire and explosion hazard. To avoid injury and death, do not store fuel or flammable liquids here.</p>

Position	Label	Description
13	 <p><b>⚠ DANGER</b></p> <p>- CONTACT WITH A SPINNING PROPELLER WILL CAUSE SERIOUS INJURY OR DEATH.          - SHUT OFF ENGINES while people are in the water near the boat, on the swim platform, or on the boarding ladder.          - NEVER OPERATE IN REVERSE TOWARD A PERSON in the water.</p>	<p><b>Danger</b></p> <p>-Contact with a spinning propeller will cause serious injury or death.</p> <p>-Shut off engines while people are in the water near the boat, on the swim platform, or on the boarding ladder.</p> <p>-Never operate in reverse toward a person in the water.</p>
13	 <p><b>⚠ DANGER</b></p> <p>CARBON MONOXIDE (CO) CAN CAUSE BRAIN DAMAGE OR DEATH. ENGINE AND GENERATOR EXHAUST CONTAINS ODORLESS AND COLORLESS CARBON MONOXIDE GAS. CARBON MONOXIDE WILL BE AROUND THE BACK OF THE BOAT WHEN ENGINES OR GENERATORS ARE RUNNING. MOVE TO FRESH AIR IF YOU FEEL NAUSEA, HEADACHE, DIZZINESS, OR DROWSINESS.</p>	<p><b>Danger</b></p> <p>Carbon monoxide (CO) can cause brain damage or death. Engine and generator exhaust contains odorless and colorless carbon monoxide gas. Carbon monoxide will be around the back of the boat when engines or generators are running. Move to fresh air if you feel nausea, headache, dizziness, or drowsiness.</p>
14		<p>Fire extinguisher</p>
15	 <p><b>⚠ DANGER</b></p> <p>LEAVING HATCH OPEN COULD INDUCE EXHAUST FUMES INTO CABIN RESULTING IN SEVERE PERSONAL INJURY OR DEATH.</p>	<p><b>Danger</b></p> <p>Leaving hatch open could induce exhaust fumes into cabin resulting in severe personal injury or death.</p>
15		<p>Emergency exit</p>
16	 <p><b>⚠ DANGER</b></p> <p>FORE AND AFT SUN PADS SHOULD NOT BE USED WHEN VESSEL IS UNDER WAY.</p>	<p><b>Danger</b></p> <p>Fore and aft sun pads should not be used when vessel is under way.</p>

Position	Label	Description
17		<p><b>Warning</b></p> <p>Carbon monoxide (CO) can cause brain damage or death. Engine and generator exhaust contains odorless and colorless carbon monoxide gas. Signs of carbon monoxide poisoning include nausea, headache, dizziness, drowsiness, and lack of consciousness. Get fresh air if anyone shows signs of carbon monoxide poisoning. See owner's manual for information regarding carbon monoxide poisoning.</p>
18	<p><b>LIQUIDS HERE IT IS ILLEGAL FOR ANY VESSEL TO DUMP PLASTIC TRASH ANYWHERE IN THE OCEAN OR NAVIGABLE WATERS OF THE UNITED STATES. ANNEX V OF THE MARPOL TREATY IS AN</b></p> <p><b>INTERNATIONAL LAW FOR A CLEANER, SAFER MARINE ENVIRONMENT. VIOLATION OF THESE REQUIREMENTS MAY RESULT IN CIVIL PENALTY UP TO \$25,000, FINE AND IMPRISONMENT.</b></p> 	<p>Liquids here. It is illegal for any vessel to dump plastic trash anywhere in the ocean or navigable waters of the United States. Annex V of the Marpol Treaty is an international law for a cleaner, safer marine environment., Violation of these requirements may result in civil penalty up to \$25,000, fine and imprisonment. U.S. lakes, rivers, bays, sounds and 3 miles from shore Illegal to dump plastic &amp; garbage, paper, metal, rags, crockery, glass, dunnage, food.</p> <p>3 to 12 miles Illegal to dump plastic, dunnage, lining &amp; packing materials that float. Also if not ground to less than one inch: paper, crockery, rags, metal, glass, food</p> <p>12 to 25 miles illegal to dump plastic, dunnage, lining &amp; packing materials that float</p> <p>Outside 25 miles illegal do dump plastic</p> <p>State and local regulations may further restrict the disposal of garbage.</p>
19		<p><b>Warning</b></p> <p>Gasoline vapors are explosive! Avoid serious injury or death from fire or explosion, resulting from leaking fuel. Inspect system for leaks at least once a year.</p> <p>Contents can be under pressure. Open slowly in a well ventilated aread.</p> <p>The use of fuels containing ethanol higher than 10% (E-10) can damage your engine or fuel system and will void the warranty. Never use (E-85).</p> <p>Open flame appliances can ignite gasoline vapors causing death or injuries from the fire or explosion. Turn off all open flame appliances when refueling.</p>

Position	Label	Description
20		<p><b>Warning</b></p> <p>Running boat with door open could induce exhaust fumes into the cabin. See the owner's manual for instructions concerning carbon monoxide.</p>
21		<p><b>Warning</b></p> <p>Carbon monoxide (CO) can cause brain damage or death. Engine and generator exhaust contains odorless and colorless carbon monoxide gas. Signs of carbon monoxide poisoning include nausea, headache, dizziness, drowsiness, and lack of consciousness. Get fresh air if anyone shows signs of carbon monoxide poisoning. See owner's manual for information regarding carbon monoxide poisoning.</p>
21		<p><b>Warning</b></p> <p>Qualified operator to be in control at all times. Operation by an unqualified operator can cause loss of control. This may result in severe injury, death, or property damage. Boat stability and handling will change with weight distribution. Read owners manual before use.</p>
21		<p><b>Warning</b></p> <p>Use caution with skier in tow as tow rope may backlash into the cockpit when released.</p>
21		<p><b>Warning</b></p> <p>Running boat with door open could induce exhaust fumes into the cabin. See the owner's manual for instructions concerning carbon monoxide.</p>
21		<p><b>Danger</b></p> <ul style="list-style-type: none"> <li>-Contact with a spinning propeller will cause serious injury or death.</li> <li>-Shut off engines while people are in the water near the boat, on the swim platform, or on the boarding ladder.</li> <li>-Never operate in reverse toward a person in the water.</li> </ul>

Position	Label	Description
21	 <p><b>YACHT CERTIFICATION</b>  <small>DESIGN COMPLIANCE WITH NMMA REQUIREMENTS IN EFFECT ON THE DATE OF CERTIFICATION IS VERIFIED.            MANUFACTURER RESPONSIBLE FOR QUALITY CONTROL.            NATIONAL MARINE MANUFACTURERS ASSOCIATION</small>  <b>THIS BOAT COMPLIES WITH U.S. COAST GUARD SAFETY STANDARDS IN EFFECT ON THE DATE OF CERTIFICATION</b>  <small>MEETS U.S. EVAP STANDARDS            USING CERTIFIED COMPONENTS</small>  <b>AXOPAR BOATS INC, BOCA RATON, FL</b></p>	<p><b>Certification plate US</b></p> <p>Design compliance with NMMA requirements and US Coast Guard safety standards.</p> <p>Meets EVAP standards using certified components.</p>
21	 <p><b>⚠ WARNING</b></p> <p>ATTACH SHUT DOWN SWITCH LANYARD TO QUALIFIED OPERATOR WHILE ENGINE IS IN OPERATION. UNCONTROLLED BOAT MAY CAUSE INJURY OR DEATH. READ OWNERS MANUAL BEFORE USE.</p>	<p><b>Warning</b></p> <p>Attach shutdown switch lanyard to a qualified operator while engine is in operation.</p> <p>Uncontrolled boat may cause injury or death.</p> <p>Read owner's manual before use.</p>
22		<p>NMMA certificate</p>
23	 <p><b>⚠ WARNING</b></p> <p>Installation of Maintenance free AGM batteries are only allowed in this area.</p>	<p><b>Warning</b></p> <p>Installation of maintenance free AGM batteries are only allowed in this area.</p>
24	 <p><b>⚠ WARNING</b></p> <p>AVOID PERSONAL INJURY STAY INSIDE DECK RAILS (AND GATES) WHEN BOAT IS UNDERWAY.</p>	<p><b>Warning</b></p> <p>Avoid personal injury. Stay inside deck rails (and gates) when boat is underway.</p>
25	 <p><b>⚠ WARNING</b></p> <p>KEEP HANDS OUT OF MACHINERY. FOLLOW UP INSTRUCTIONS FOR REMOTE CONTROL ENABLING.</p>	<p><b>Warning</b></p> <p>Keep hands out of machinery.</p> <p>Follow up instructions for remote control enabling.</p>

## 3 Product overview

### 3.1 Purpose of use

The boat is a recreational boat, thus not suitable for professional use.

### 3.2 Identification

Each boat has a unique identification code, containing 14 characters and a hyphen.

The height of the code text is 6 mm, and it is located on the starboard side of the stern.

Example: FI – AXO9C010F324	Data
FI	Country of manufacturer: Finland
-	Hyphen
AXO	Manufacturer: Axopar Boats
9B	Boat model • C = XC Cross Cabin
010	Boat number
F	Manufacturing month • A = January • B = February • C = March • etc.
3	Last digit of the manufacturing year
24	Model year



### 3.3 Builder's plate

The builder's plate is always located close to the steering position of the boat.

Boat has been inspected according to Recreational Craft Directive and related standards' requirements. HPI Verification Services Ltd. has assigned EU Type-Examination Certificate (CE certificate) to the boat model.

Boat carries UKCA marking (shown in right bottom corner of CE plate) to indicate that it complies with the UK Recreational Craft Regulations.

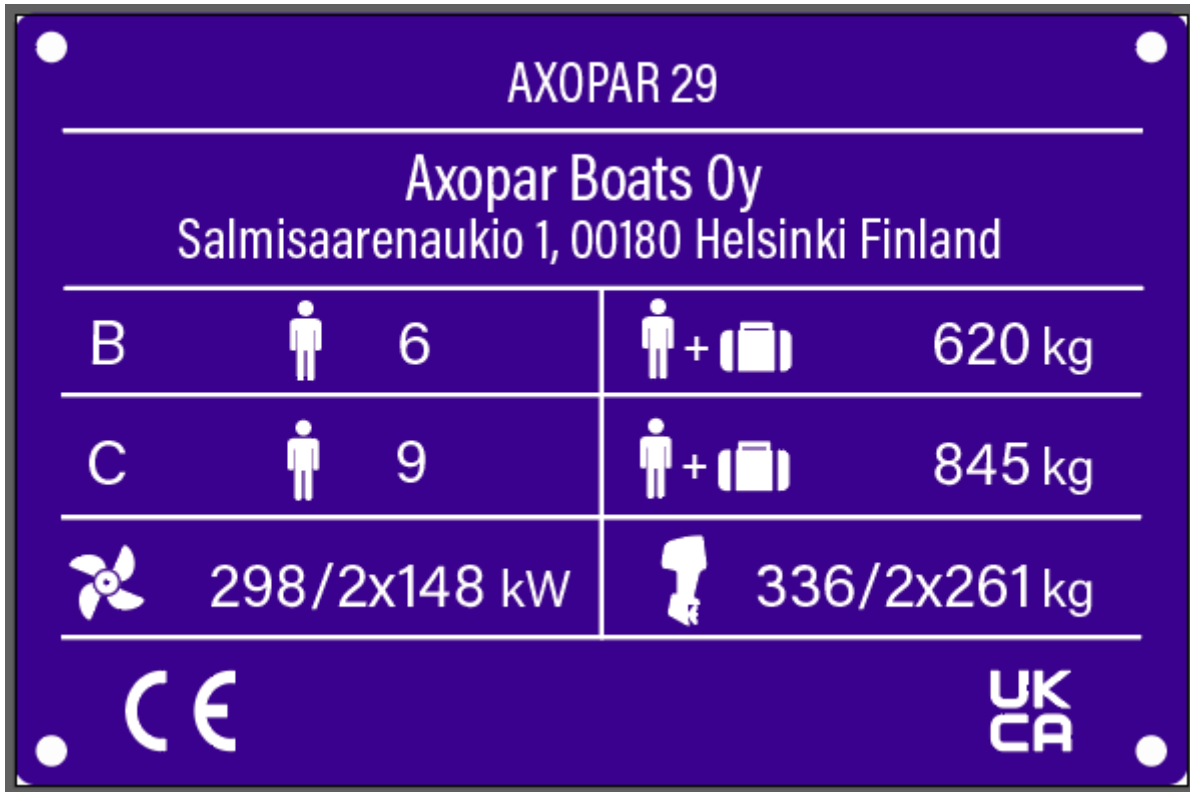

The builder's plate contains the following information:

- Boat model
- Manufacturer's address
- Maximum number of persons on board
- Maximum load: total weight of persons including personal luggage and basic equipment, and excluding tank contents
- Maximum engine power
- Maximum engine weight

### 3.4 CE certification

The category is determined according to the maximum number of persons allowed onboard.

The CE certification indicates that a boat is designed and built in such a way that it retains its stability and buoyancy in given circumstances and meets other important requirements that are characteristic of the category in question. One of these requirements is that the boat must be easy to maneuver.

The CE categories classification also signifies that a boat is designed and constructed to withstand the following parameters in respect of stability, buoyancy, and other relevant essential requirements stated.

Category	Description
A. Ocean	The boat is designed for extended voyages, where conditions experienced may exceed wind force 8 on Beaufort Scale and include significant wave heights of at least 4 meters. Under such conditions, the boat must be largely self-sufficient.
B. Offshore	The boat is designed for offshore voyages, where conditions up to and including wind force 8 on Beaufort Scale and significant wave heights up to and including 4 meters may be experienced.
C. Inshore	The boat is designed for voyages in coastal waters, large bays, estuaries, lakes and rivers, where conditions up to and including wind force 6 Beaufort Scale and significant wave heights up to and including 2 m may be experienced.

## 3.5 Dimensions and weight

### Dimensions

Dimension	SI units	US units
Hull length (LH)	9.31 m	30 ft 7 in
Overall length (LMAX) (excluding engine)	9.71 m	31 ft 10 in
Hull beam (BH)	2.92 m	9 ft 7 in
BMAX	3.0 m	9 ft 10 in
Draught at max. load (excluding engine)	0.62 m	2 ft
Draught to props	approx 0.93 m	3 ft 6 in
Height measured from waterline at light load (excluding antennas)	3.03 m	9 ft 12 in

### Engines

	SI units	US units
Maximum recommended engine power	298 kW	400 hp
Maximum recommended power with twin engines	2 x 148 kW	2 x 200 hp

	SI units	US units
Maximum recommended engine weight, single engine	336 kg	741 lb
Maximum recommended engine weight, twin engine	2x261 kg	2x575 lb

### Weight and loading

	Category B		Category C	
	SI units	US units	SI units	US units
Hull weight (excluding engines)	2900 kg	6393 lb	2900 kg	6393 lb
Weight of unloaded boat with maximum weight outboard engines (MLC)	3609 kg	7957 lb	3609 kg	7957 lb
Boat weight at maximum load (MLDC)	4710 kg	10384 lb	4935 kg	10880 lb
Mass on trailer	4140 kg	9127 lb	4140 kg	9127 lb

### Load components

	Category B		Category C	
	SI units	US units	SI units	US units
Maximum recommended load	1101 kg	2427 lb	1326 kg	2923 lb

of which

	Category B		Category C	
	SI units	US units	SI units	US units
Total weight of all persons	450 kg	992 lb	675 kg	1488 lb
Personal luggage	80 kg	176 lb	80 kg	176 lb
Life raft weight	50 kg	110 lb	50 kg	110 lb

	Category B		Category C	
	SI units	US units	SI units	US units
Optional - Load on roof racks	40 kg	88 lb	40 kg	88 lb
Total weight of fuel, water and other liquids	481 kg	1060 lb	481 kg	1060 lb

**Tank capacity**

	SI units	US units
Fuel tank	400 l	105 gal
Fresh water tank	42 l	11 gal
Septic tank	42 l	11 gal
Optional - Heater fuel (23 l)	19 kg	42 lb
Optional - Bait well (100 l)	98 kg	216 lb

The boat's stability assessment is based on maximum load conditions.

The maximum recommended load only contains the weight components mentioned above.

**3.6 Boat layout**

The boat has several deck options. The layout of the equipment and the technical components may vary depending on the chosen accessories.

The standard boat has a flat aft deck with stowage underneath.

The storage can be replaced with optional extra equipment such as an aft cabin, a storage bench or a wetbar.

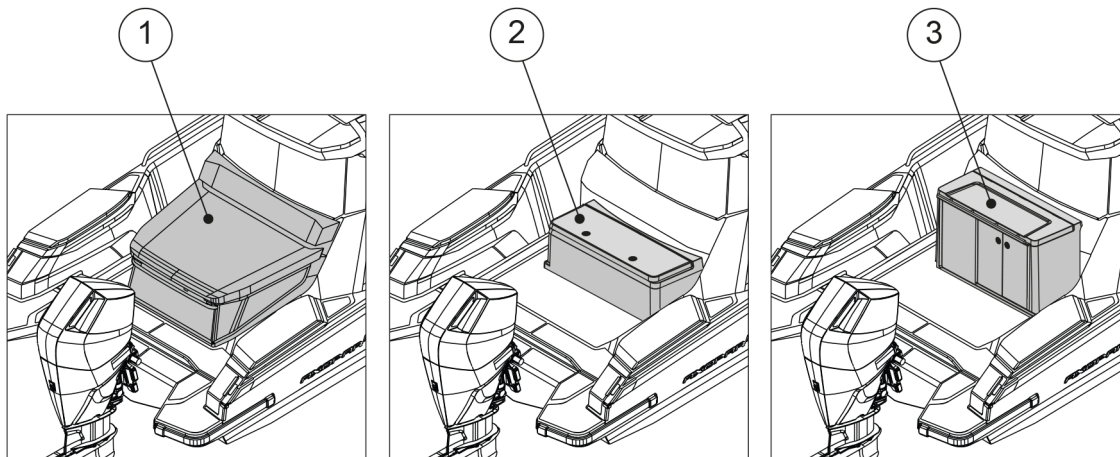

- (1) Aft cabin
- (2) Storage bench
- (3) Wetbar

As an option, the cabin can be equipped with seat base refrigerator and sink. In the front part of the cabin, there is a separate multicabin with a door that opens to the front deck. The multicabin can be equipped with a toilet package and furnished with an accommodation package.

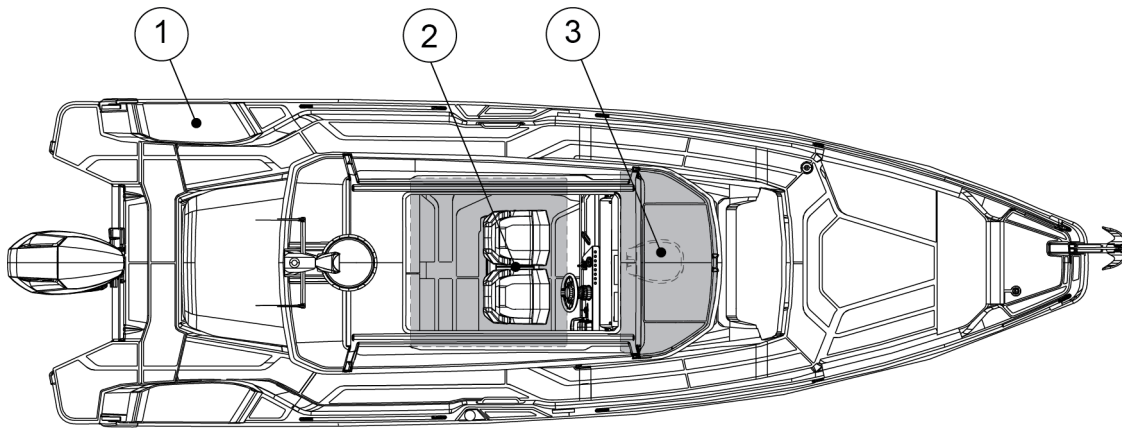

- (1) Optional fender box wetbar
- (2) Optional seatbase refrigerator and sink
- (3) Multicabin or optional toilet

## 4 Product description

### 4.1 Stability and buoyancy

Pay attention to the stability and buoyancy of the boat.

All weight dispositions (for example installing a fishing tower or radar, and engine replacement) can have a significant impact on the stability, trim, and performance of the boat.

- The bilge water level needs to be kept at a minimum.
- The stability of the boat is compromised if any weight is placed in a high position.

In stormy weather, all hatches, compartments and doors must be kept closed to minimize the risk of flooding.

Breaking waves represent a significant danger to stability.

#### **WARNING**

To avoid the risk of flooding, always keep the seacocks closed when not in use (for example, the seacock for the toilet's flushing water).

#### 4.1.1 Self-draining systems

The boat is equipped with self-draining systems for the whole deck area. The system is drained through drain holes in the aft of the boat. In addition to rainwater, the drain holes are intended to drain water ending up on the deck through splashing or from breaking waves.

There are drain holes for water in both aft corners of the deck. The openings are directly connected to the sea. The deck of the boat has been designed to allow the water to drain straight into the sea via the water gullies.

#### **CAUTION**

Do not close the drain holes when using the boat.

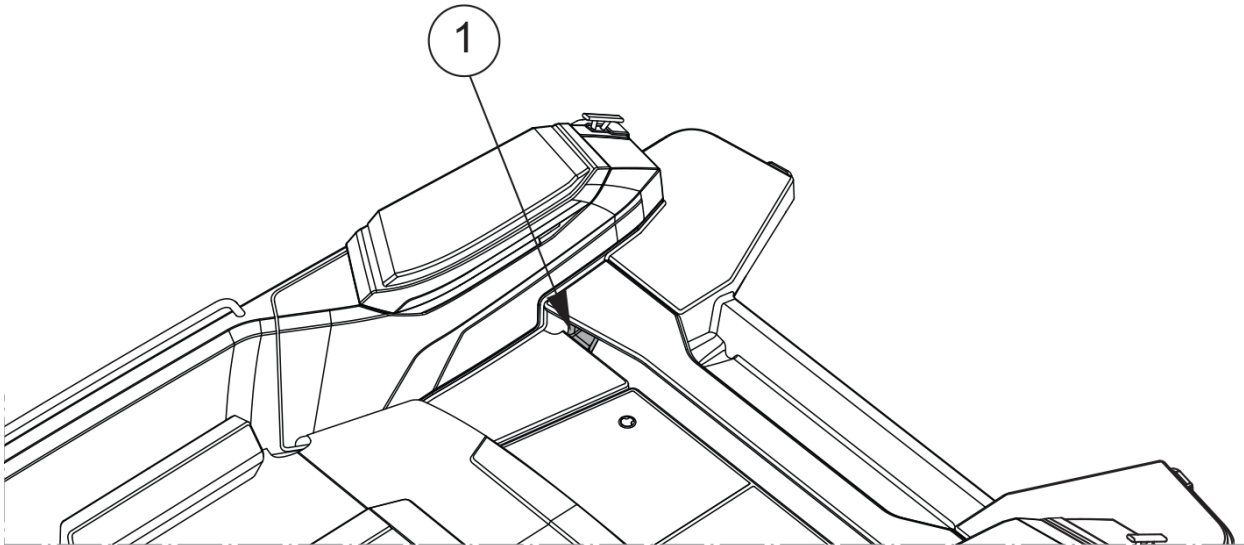

(1) Drain hole

The drain holes must be open at all times. Clean the holes regularly by removing any accumulated debris to prevent clogging.

The system is built so as to drain the water from the deck in normal use. Do not close the taps when using the boat or when the boat is attached to the dock.

**NOTICE**

The self-emptying open space is meant for the removal of such water that ends up on the deck through rain, splashing or from breaking waves. A part of the rain water as well as water condensation in the bilge may end up in the bilge.

- Do not leave the boat unattended in the water for a long time.
- Observe the floating position of the boat and empty the bilge when necessary.

Leaving the boat unattended in the water for a long time may cause damage.

### 4.1.2 Openings in the hull and deck

There are several inlets through the boat that include valves for opening and closing such inlets. It is recommended to keep these inlets closed if the boat is out of use for a long time, and to open them again when the boat is used again. If the boat is lifted out from water or in rainy conditions, inlets should be kept open.

Always check that all hatches are securely closed before and after using the boat.

Always check in the spring when launching that the inlets through the side and bottom are tightly closed.

We recommend that you keep the windows, doors, deck hatches, roof hatches, vents and interior doors closed while driving. In stormy weather, always keep them securely closed to minimize the risk of water getting into the boat and to avoid any personal injuries.

In certain conditions and speeds, it is possible that water is sprayed inside through canopies, hatches or other openings, due to negative pressure or other effects. Risk for this can be minimized by closing the canopies, hatches or other openings.

**⚠ WARNING**

All doors and hatches must be kept shut when under way.

The figure shows the hatches and seacocks that must be kept closed when the boat is left unattended. Keep hatches closed also while underway.

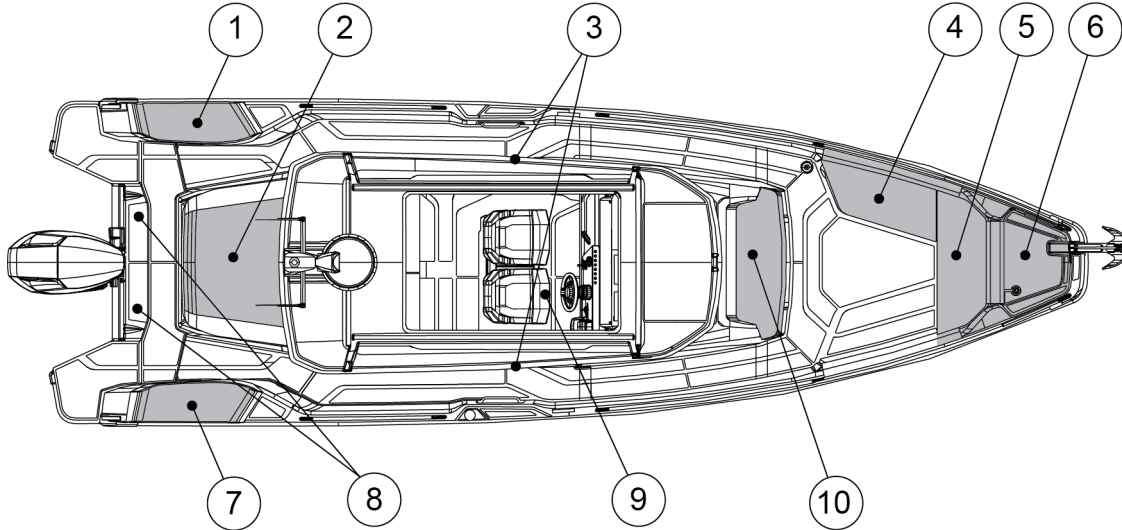

- (1) Port fender box hatch
- (2) Aft deck hatch / aft cabin hatch
- (3) Cabin door
- (4) Side storage box
- (5) Front storage box
- (6) Anchor hatch
- (7) Starboard fender box hatch
- (8) Inspection hatches
- (9) Fuel tank compartment inspection hatch
- (10) Multicabin

The location and number of these components depend on the level of the equipment on the boat.



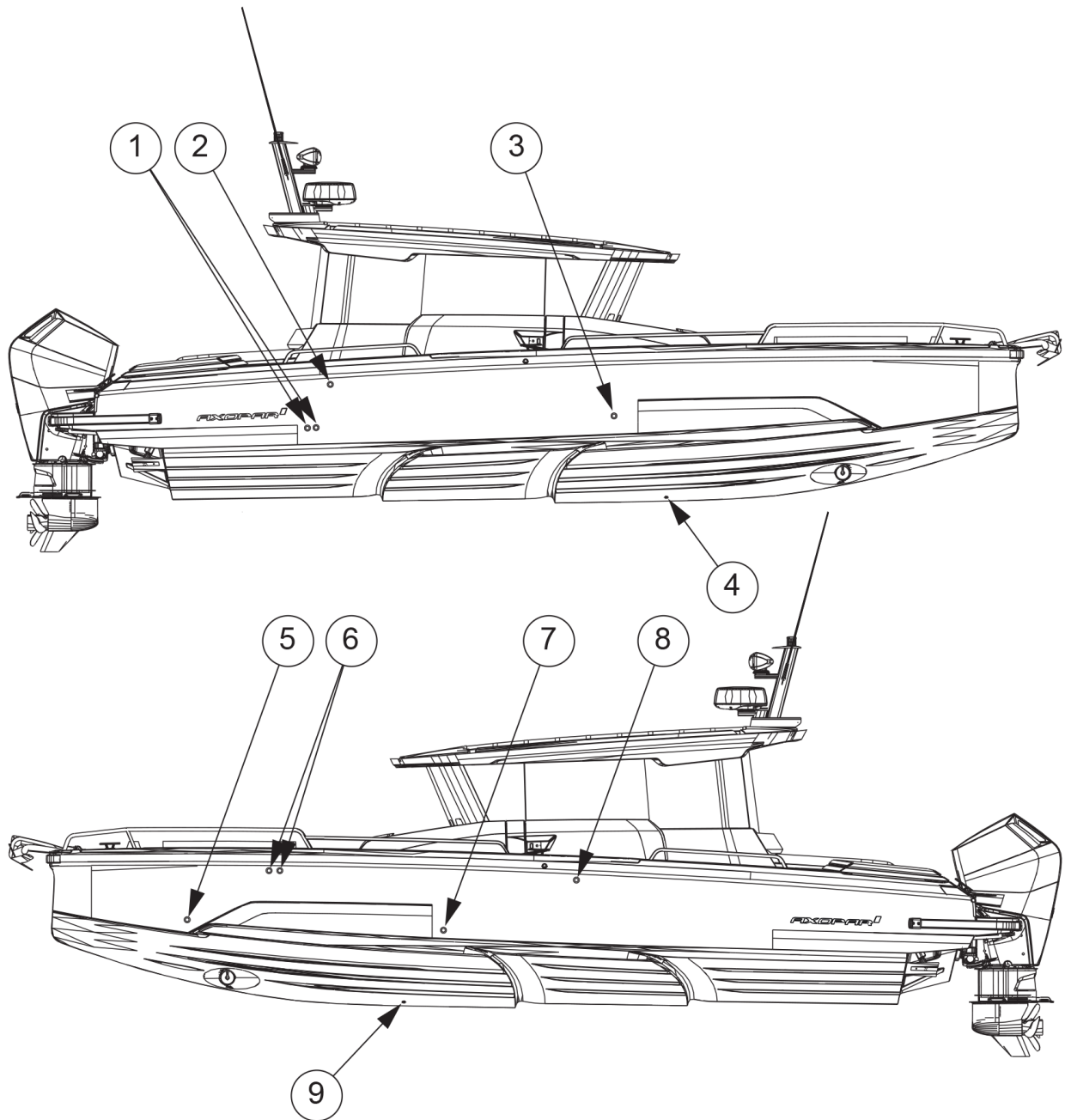

- (1) Electric and manual bilge pump outlets
- (2) Heaters fuel tank vent
- (3) Grey water outlet
- (4) Black water tank seacock
- (5) Manual front bilge pump outlet
- (6) Fresh water and black water tank vents
- (7) Electric front bilge pump outlet
- (8) Heater exhaust
- (9) Transducer

### 4.1.3 Bilge system

The bilge system is designed to enable keeping the bilge water level at a minimum. The system consists of several pumps that cover all the lower sections of the boat.

The boat is equipped with both manual and electric bilge pumps. The signs on the boat display the draining area of each pump.

The manual bilge pump is controlled with its handle.

The submersible electric bilge pumps are equipped with a float which triggers them automatically if there is water in the bilge space. The electric bilge pumps can also be controlled manually from the switches on the steering console.

**⚠ WARNING**

The bilge system is not designed for damage control.

The combined capacity of the bilge system is not designed to pump out the boat in the event of hull damage.

**NOTICE**

Keep the bilge area clean by washing it ever so often using bilge cleaner or biodegradable soap and water. Clean bilge significantly helps noticing signs of leaks or other problems that may occur.

**NOTICE**

- Check the functionality of the bilge pumps regularly by manually activating them.
- Remove any waste from the intakes.
- Clear the pump outlets from debris.

If seacocks are fitted in the fore and aft peak bulkheads, keep them closed, and only open to let water drain into the main bilges.

**NOTICE**

Do not run the pumps dry for a long time. The pumps will be damaged.

**NOTICE**

Avoid pollution.

Since the bilge system comprises of several automatic and manual pumps that cover all areas of the boat, the risk of accidental discharge of contaminated water by automatic pumps needs to be minimized.

Mitigate the risk by checking the bilge water regularly for contaminants such as oil, diesel, and glycol.

**Before every use**

Make sure that:

- The bilge pumps can operate freely, and there are no objects blocking operation.
- Water can flow through the strainer, and there is no muck or material restricting the water flow.  
Clean the strainer by pushing the lock tabs in the pump motor and lifting the motor unit off.

### 4.1.3.1 Bilge pumps

#### Bilge pump output

The manual and automatic bilge pump output exceeds the minimum of 15 liters (4 gallons) per minute.

#### Bilge pump locations

The manual bilge pump's control handle is located in the starboard side fender storage in the aft deck.

The electric bilge pumps are submersible.

One electric bilge pump is located under the berth of the aft cabin.

The second electric bilge pump can be accessed through the multicabin. The electric pumps are by default in automatic mode and pump out the bilge once the float-switch is triggered. The electric bilge pumps can also be started manually from the boat's main control panel.

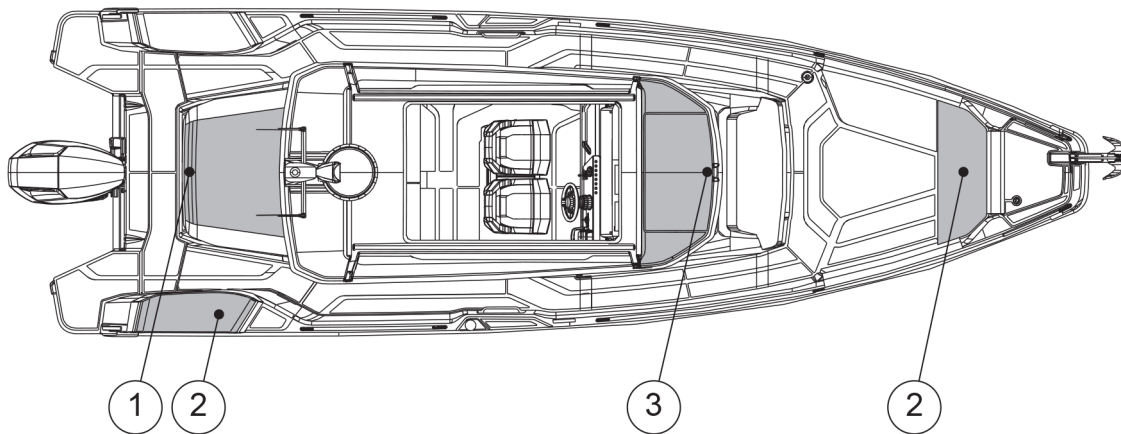

- (1) Aft electric bilge pump
- (2) Manual bilge pump
- (3) Front electric bilge pump

## 4.2 Technical systems

### 4.2.1 Electrical system

**⚠ WARNING**

**Risks of fire, explosion and electric shock!**

Improper use of electric DC and AC systems may result in fire, explosion or electric shock.

Follow the instructions carefully.

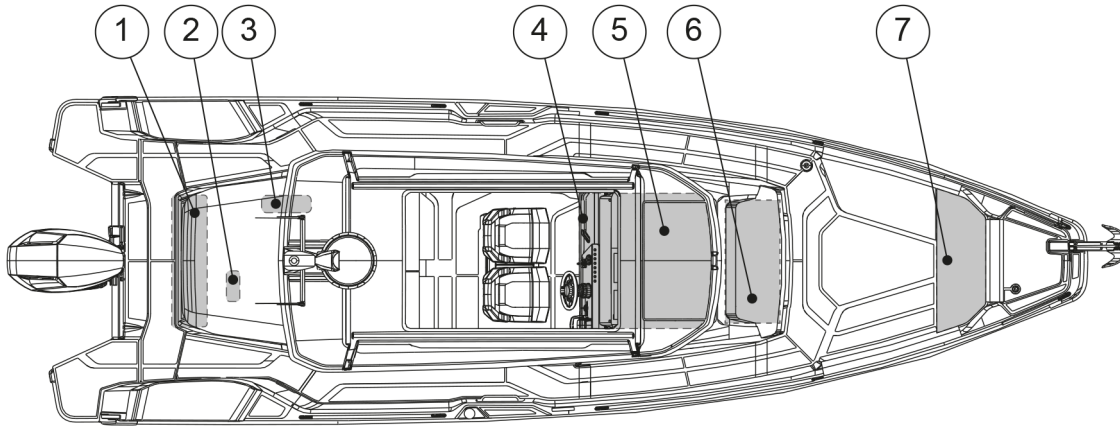

- (1) Batteries
- (2) Shore power system battery charger
- (3) Main switch panel
- (4) Optional remote main switch panel
- (5) Fuse panel
- (6) Bow thruster and windlass fuses; Aux battery with charger
- (7) Shore power plug and fuse switches

## 4.2.2 12 V system

Most of the boat's equipment uses the 12 V system.

The 12 V system consists of engine driven alternators, battery chargers for shore-side electricity, batteries and equipment. The power is supplied to the batteries via diodes from either the engine alternator or the shore power charger.

To activate the circuits in the 12V system, the main switches for the corresponding circuits need to be activated and the fuses intact. When the electronic circuit is switched on, the equipment can be operated from the main switch panel.

### **⚠ WARNING**

- Never switch off the main switch when the engine is running, because this may cause damage to the alternator.
- Never carry out electrical installations when the power is switched on.
- Never modify the boat's electrical system or diagrams. Service and maintenance must be carried out by a qualified electrician.
- Never alter or modify the rated amperage of the overcurrent protective devices.
- Never install or replace electrical equipment with components that cause the circuit's nominal rated amperage to be exceeded.
- Never leave the boat unattended with the electrical system energized, except automatic bilge pump, fire protection, and alarm circuits.
- Maintain any damaged equipment before taking it back to use.

### 4.2.3 Main switches

The different electronic circuits of the boat are controlled by the main switches on the distribution board.

The main switches allow the batteries to be disconnected from all devices that consume electricity. When the main switches are in the On position, the current is conducted to the distribution board and from there to different parts of the boat.

The background color of the main switch and the text On shows that the electronic circuit is switched on, and when the circuit is switched off, the background color is red and the text says Off.

When you leave the boat for any length of time, switch off the current from all main switches. Devices that constantly need current are active regardless of the position of the main switches.

The design drawing of the boat's electrical system is presented in **Appendix II**. The main switch is located under the after seat. In the main switch panel, there are direct supply switches for critical equipment and main switches for the start batteries, the service battery and the Aux battery.

Current is fed to the engine by turning the Start switch to the On position. The current feed to other equipment is achieved by turning the Service switch to the On position, and feed to the bow thruster and windlasses is achieved by turning the Aux switch to the On position.

#### Main switch panel

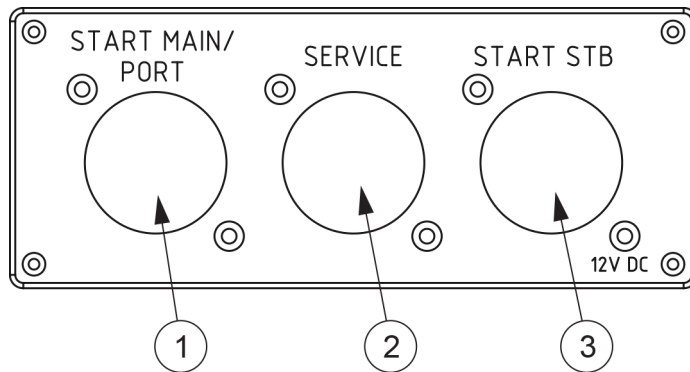

- (1) Start batteries
- (2) Service battery
- (3) Optional second engine main switch

**Optional remote main switch panel**

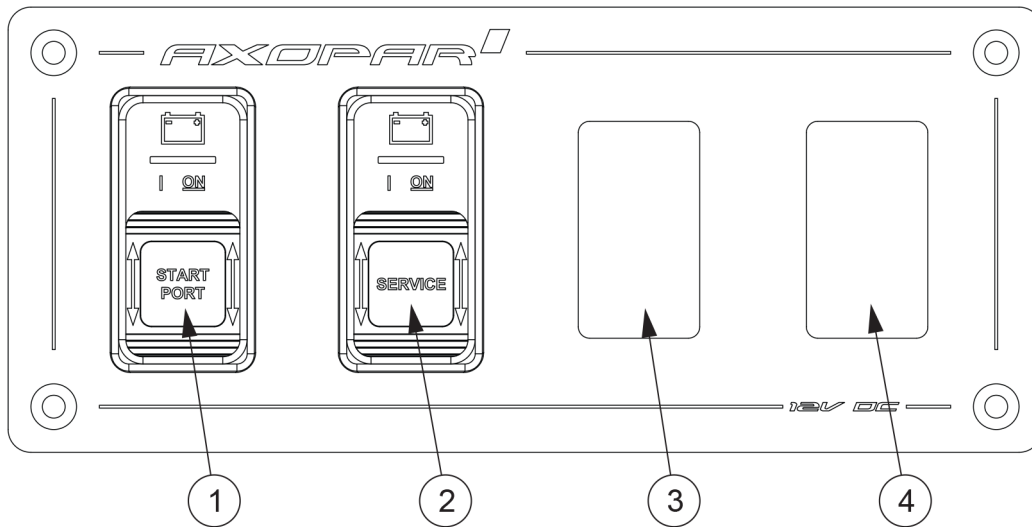

- (1) Start batteries
- (2) Service battery
- (3) Space for the switch of optional second engine
- (4) Space for the switch of optional bow thruster and windlass

**4.2.4 Direct supply fuses**

Some of the devices in the boat are supplied by direct supply switches. Direct supply switches are intended for such equipment that need current when the main switches are turned off.

When pushed down, the switch is on and when pushed up it is off. The switch indicates a short circuit or interference in the electronic circuit by springing up to the “off” position. The switch can be reconnected by pushing it back down to the “on” position. Do not reconnect the switch before you have found out the reason for the interference.

The direct supply switches must be left on even if the current from other circuits is switched off. An appliance that is switched off too early may cause the appliance to overheat and become damaged.

**⚠ WARNING**

Turning the direct supply switch off too early may cause the device (for example, the heater) to break or catch fire, because the devices have a ventilation feature that works even if the device is otherwise switched off.

- Make sure the device is cooled down before turning it off completely. For more information, see the manual of the device in question.

**4.2.5 Fuses**

The fuse panel includes fuses for the boat’s equipment. The fuse panel is located in the front multicabin.

The fuses are in the form of trip switches that break the circuit and spring up when tripped. Do not reset the switch before you have found out the reason for the breaker tripping. After that press the switch back down.

The panel has a switch for the macerator.

**⚠ WARNING**

Before connecting an electric circuit, make sure that the circuit is not damaged and that there will be no short circuit or a fire caused by possible damages in the electric circuit. Any damaged equipment must be maintained or changed before they are again taken into use.

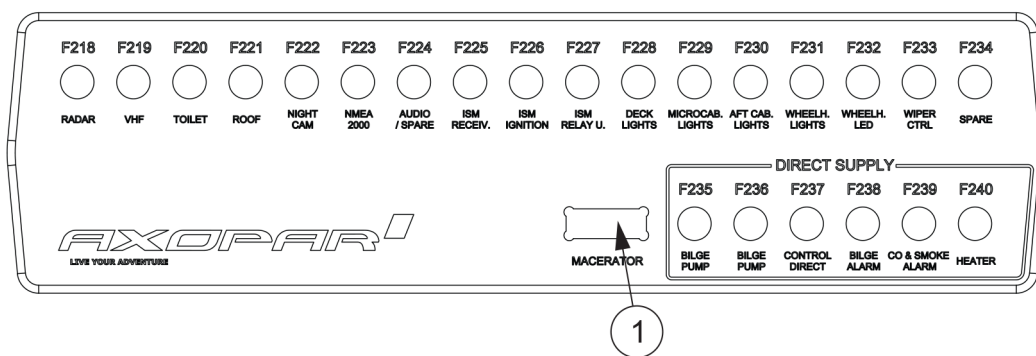
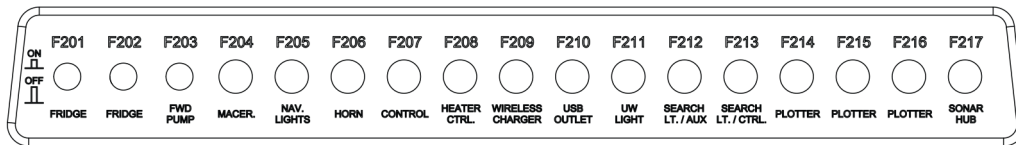

(1) Macerator pump switch

### 4.2.6 Heavy duty fuses

There are fuse panels containing fuses for appliances and electronic circuits which require large currents, such as windlasses, in the boat.

The bow thruster's and windlasses' high current fuses are located under the service hatch in the multicabin and the battery charger fuses in the technical space under the aft deck.

The functioning of fuses can be checked from the holes in the fuse's cover. If the metal strip visible in the hole is unbroken, the fuse is operational.

If the metal strip is damaged, meaning that an overload has occurred, contact a qualified nautical electrician.

**⚠ WARNING**

Opening the cover is not recommended, as there is a danger of electric shock and serious injury.

If the metal strip is damaged, contact a qualified nautical electrician. If it is necessary to open the cover, make sure that all the current cables from the batteries are disconnected.

## 4.2.7 Batteries

The boat is equipped with 2-4 batteries. The amount of start batteries depends on the engine selection. The start batteries supply current to the engine(s) and engine-related equipment, and the service battery for other appliances and equipment on the boat. There is a separate battery for the bow thruster.

The dual battery system has been designed and built so that the boat's engine starts even if its service battery is empty. When the dual battery system has been installed, the start battery only supplies current for the engine system. All other power consuming devices have been connected on to service battery. The batteries are charged by the engine alternator. Charging of the batteries is arranged so that the start batteries are always prioritized. Once the start batteries are full, charging of the service batteries starts automatically.

The batteries are located in the aft of the boat. The exact location of the batteries is presented in the section **Electrical System**.

### **WARNING**

Only use maintenance-free AGM batteries in the boat.

- When you leave the boat, switch off the current from the main switch.
- Remove the batteries from the boat for winter storage.
  - When removing a battery, detach the negative pole first.
  - When disconnecting batteries, be careful not to touch both poles at the same time with a metal tool.

### 4.2.7.1 Charging the batteries

#### **WARNING**

- Remember that the batteries discharge an explosive oxy-hydrogen gas at a voltage of 14.4 volts.
  - The voltage of a normal battery in unloaded status is 12.3-12.7 V.
  - During charging, the voltage increases and the charging regulator stops the charging process automatically at a preset level.
  - The voltage measurement must be taken at the battery terminals, not the alternator, to achieve the correct result.

### 4.2.7.2 Winter storage

For winter storage, the batteries can be left on board only if they are fully charged.

A partially discharged battery can freeze and crack. Always disconnect the cable terminals from the battery to avoid oxidation. When removing batteries, disconnect the negative pole first and make sure that there are no flammable or explosive materials or liquids nearby. When putting the batteries back in place, connect them in reverse order (positive pole first).

### 4.2.7.3 Cleaning the batteries

The top of the batteries needs to be cleaned regularly to avoid current leakage between the cells. If the battery is located in a separate area, it is normally sufficient to clean it in the spring and autumn.



Make sure that the air holes in the cell plugs are open so that gas can be vented.

The terminals and cable terminals must be lubricated to prevent deposits and corrosion.

## 4.2.8 110/230 V system

You can choose to equip your boat with the optional 110/230 V AC system with a shore power connection, which will allow you to use devices that run on the standard mains current.

The system obtains its power from an external supply on shore or from the jetty (shore power). In the European market the system used is 230 V and in the American market 110 V.

The system functions when a shore power cable has been connected to the shore power socket connection.

1. Turn off the shore power switch before connecting or disconnecting the cable.
2. Connect the shore power cable to the boat before connecting it to the shore power.
3. Disconnect the shore power cable from the shore power before disconnecting from the boat.
4. Close the hatch of the boat's shore power connection.

### CAUTION

Unplug the shore power cable before starting the engines. Starting the engines with the shore power cable connected may break the battery isolators.

The system's main fuse is located in a separate control panel. The system includes a battery charger, which starts charging batteries automatically when the boat has been connected to shore power. The location of the components is presented in the section **Electrical System**.

The shore power system needs to be checked at least biannually. Always disconnect the shore power cable when the system is not in use. Metal casings of installed electrical equipment must always be connected to earth in the boat electrical system. Use electrical equipment equipped with earth protection only.

### DANGER

Risk of electric shock and fire!

- Do not touch an energized high voltage system.
- Do not change the plug of the shore power cable. Use compatible connectors only.
- Try to minimize the risk of electric shock, short circuit and fire.
- Do not allow the shore power cable to hang in the water. If it does, a hazardous electric field could be created in the water.
- Never modify the connections on the shore power cable. Use compatible connectors only.
- If the earth fault breaker is tripped, disconnect the shore power cable immediately. In such a case contact a qualified electrician for repairs before the system is used again.

**⚠ DANGER**

To avoid an electric shock and risk of fire:

- Switch off the shore power switch before connecting and disconnecting the cable.
- Connect the shore power cable to the boat before connecting it ashore.
- Disconnect the shore power cable ashore before disconnecting it from the boat.
- Close the hatch to the shore power socket on the boat carefully, avoiding getting it wet.

## 4.2.9 Fuel system

The boat has a fixed fuel system and a water-separating fuel filter on the suction line.

Instead of the fuel system used in the European region, the boats produced for the American region use the EPA (United States Environmental Protection Agency) fuel system regarding NMMA (National Marine Manufacturers Association) certification rules.

See the fuel system drawing in **Appendix II**. For care and maintenance of the fuel system, see the instructions in the engine manual.

**⚠ WARNING**

Never start the engines if there is strong gasoline odor present.

**⚠ WARNING**

Risk of fire.

- Do not smoke or handle open flames when refueling.
- Remember that it is not allowed to store fuel in spaces not specifically designed for it. Since there is no ventilated storage space on the boat, possible spare fuel cans must be stored on deck.

### Fuel system component locations

- The fuel tank is located in the middle of the keel. Prevent damage to the fuel lines.
- The components of the tank, the fuel filter (if available) and the fuel tank valves are located under the driver's seat. The EPA fuel system is equipped with an automatic fuel valve.
- The inlet pipe for fuel is located in the starboard side of the deck.

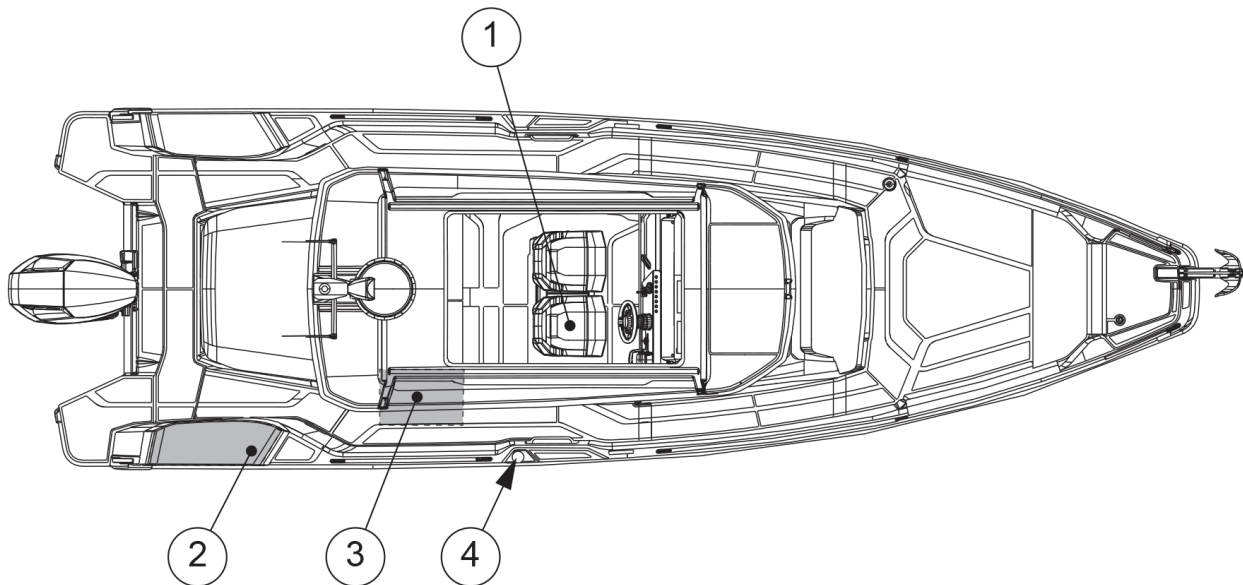

- (1) Fuel tank and valve
- (2) Diesel tank inlet
- (3) Optional diesel tank
- (4) Fuel inlet fitting

#### 4.2.9.1 Refueling the boat

If the boat has optional decking material, wet down the deck with water before refueling. This ensures that any fuel spillage will float on the water and not penetrate the decking material.

Water reaching the engine's injection system can cause rapid corrosion damage to the precision components in the injection pump components. For this reason, it is vital to check the extra fuel filter regularly for water. Every so often, drain a small quantity of fuel into a suitable container (avoid fuel spillage) and check that there is no condensation water. If there is water in the filter, continue to drain until only clean fuel appears.

The fuel system on the engine is sensitive to air bubbles in the fuel. Always fill the tanks well before they are completely empty. If the system has been run dry, it must be bled before the engine can be started again. See the engine manufacturer's instruction manual before bleeding the fuel system.

#### **⚠ WARNING**

- Never block access to safety equipment, fire extinguishers, fuel valves or main power switches.
- Never block any ventilation openings made in the boat because their purpose is to clear the air of fuel fumes.
- Never use a wrong type of fuel in the heater or cooker as this may damage them.
- Never use an open flame when detecting leaks.

### 4.2.9.2 Maintaining the fuel system

Follow the engine manufacturer's maintenance schedule.

- Annually, check the condition of the hoses and make sure that there are no visible cracks, abrasion, or deterioration.
- Replace worn parts with genuine, marine-grade parts only.
- Bi-annually and for winter storage, check the fuel tank compartment for possible accumulated water. This can be done by inserting a thin hose through the aluminium pipe at top of the tank. The pipe guides the hose to the lowest part of the fuel tank compartment. The compartment can then be emptied with wet-dry vacuum cleaner connected to the hose.
- Bi-monthly, inspect the fuel system for presence of water in the fuel tank.

Presence of water in fuel can be checked by inspecting the contents of the fuel filter.

If any water is found, it must be removed and the whole fuel tank dried before the tank can be refilled with fuel.

- Examine the fuel tank and lines for corrosion and leaks.

Bi-annually and for winter storage, check the fuel tank compartment for possible accumulated water as follows:

1. Insert a thin hose through the aluminium pipe at top of the tank. The pipe guides the hose to the lowest part of the fuel tank compartment.
2. Connect a wet-dry vacuum cleaner to the hose.
3. Empty the compartment.

## 4.3 Optional equipment

This section presents the optional equipment and systems available for the boat.

### 4.3.1 Fresh water system

You can choose to equip your boat with a fresh water system as an optional extra.

The fresh water system consists of a fresh water tank, pump and accumulator. The boat may also be equipped with a water supply point in the galley and a deck shower and a water supply point for the wet bar.

The tank is located under front deck. The fresh water tank is filled via the inlet pipe on the foredeck.

The fresh water system is turned on by switching on the fresh water pump. The pump switch is located on the fuse panel.

The system maintains a working pressure automatically. The water pump has automatic pressure sensor which activates and shuts down the pump as needed.

Switch the system off when leaving the boat. Do not forget to check filter in the pump regularly.

The dealer is responsible for disinfecting the fresh water tank before sale.

**NOTICE**

The water from the system is not meant for drinking.

The fresh water system must be thoroughly emptied for winter storage. It is not recommended to use any anti-freeze products in the fresh water system.

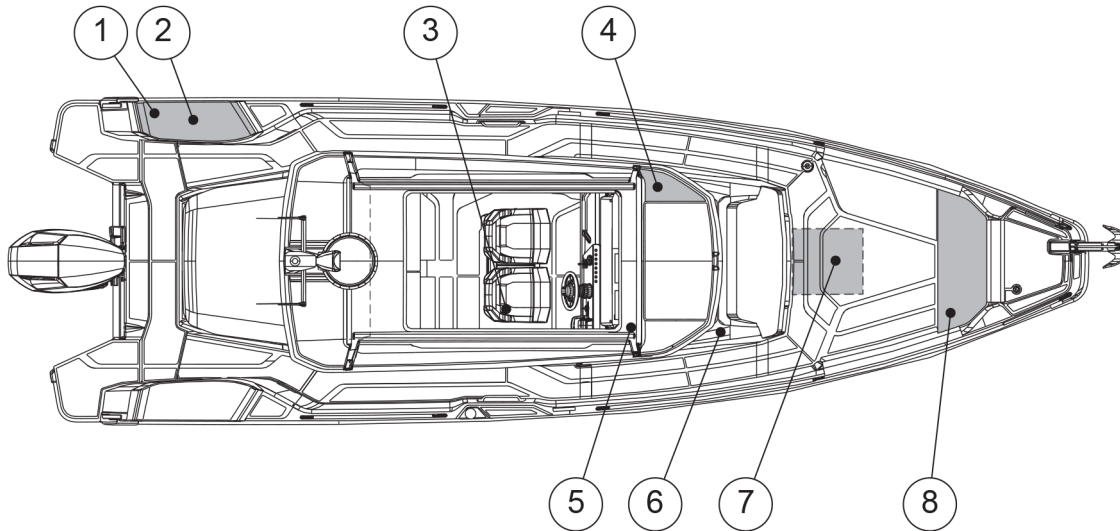

- (1) Deck shower
- (2) Wetbar tap
- (3) Galley tap
- (4) Fresh water pump switch
- (5) Toilet tap
- (6) Fresh water pump
- (7) Fresh water tank
- (8) Water inlet

The water pump has air release valve which should be slightly opened to facilitate priming when starting the pump or emptying the tank. Once the pump operates normally, the valve should be closed.

The water pump has also two LEDs indicating the operating status and faults in the pump operation. For more information about the signals, please refer to manufacturer's manual.

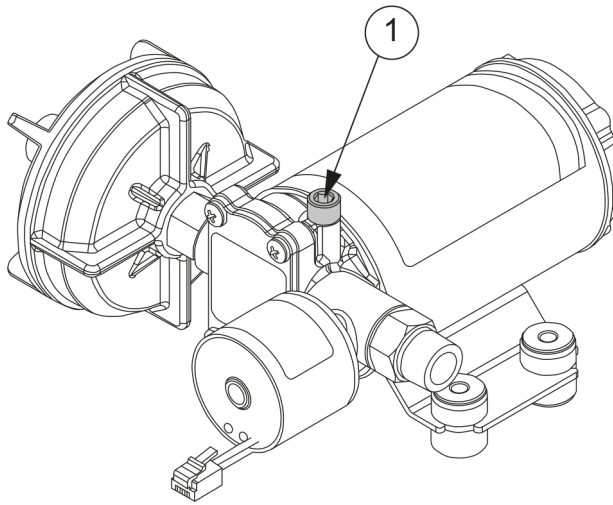

Figure 4.1 Water pump and air release valve

Fresh water system needs to be disinfected and flushed annually or after longer periods of non-use to keep the system in working order.

Disinfection procedure is described below:

1. Flush the entire system thoroughly by running potable water to flow through it.
2. Drain the system completely.
3. Fill the entire system with disinfecting solution and follow the manufacturer's instructions.
4. Drain the entire system once disinfection process is complete.
5. Flush the entire system thoroughly several more times with potable water.
6. Fill the system with potable water. Fresh water system is now ready to be used.

**Maintenance:** Annually inspect hose connections, tube fittings and pump electrical wiring connections for proper securing and no chafing. Water pump inlet filter is recommended to be checked and cleaned annually. Running the system regularly helps keep the water pump's impellers in working order.

## 4.3.2 Septic system

The boat's septic system consists of the toilet seat, the septic tank and the related systems.

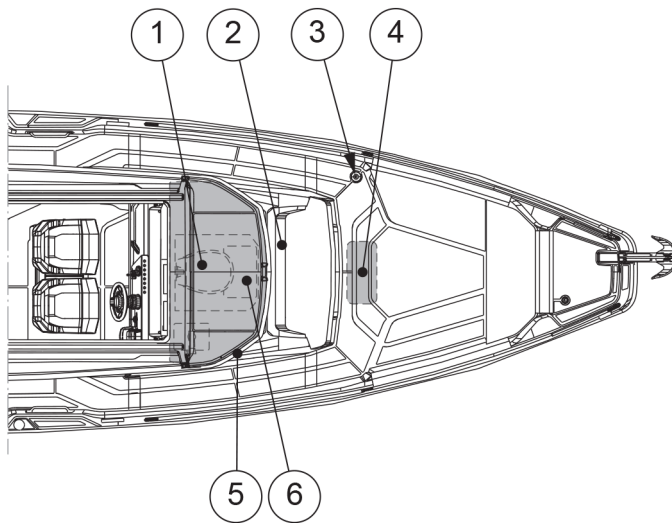

- (1) Toilet seat
- (2) Septic macerator
- (3) Septic tank suction fitting
- (4) Septic tank
- (5) Toilet seat pump
- (6) Septic tank seacock and raw water intake seacock

### Maintaining the macerator

The macerator pump can get stuck if it is not used for extended periods of time. Regular use of the macerator helps to prevent this from happening.

If the macerator pump gets stuck, please contact your dealer for repairs.

### 4.3.2.1 Toilet seat

#### NOTICE

- Never put any other objects but toilet paper in the toilet.
- In order to avoid damages, you must also not pour hotter than lukewarm water into the toilet.
- It is under no circumstances allowed to flush paper towels, fabric or rubber products, hard objects, oil products or solvents down the toilet.

### Using the electrical toilet

The electrical toilet is used with a separate operating switch. For more information on the device, see the manual for the toilet.

## Maintaining the toilet

- Clean the toilet with a mild cleaner.
- Never use cleaning agents or deodorants which contain pine oil, formaldehyde or chlorine, nor corrosive or petroleum-based agents.

These materials can damage the plastic and rubber parts in the toilet.

- Lubricate the pump shaft with Vaseline to increase the service life of the seal.
- Flush the toilet system thoroughly with fresh water when the boat is not in use.

### 4.3.2.2 Septic tank



Avoid environmental pollution!

The black water tank is fitted with a deck outlet pump using an international standard type connection. Using the pump, the black water can be emptied to a permanent septic tanks ashore. These facilities must always be used.

In areas where there are no permanent septic tanks, the macerator is used to evacuate the contents of the tank straight into the water as follows: Open the sealed seacock. If possible, empty the tank daily and always in deep waters far from the shore. For the location of the pump, see the section **Septic system**.



The shut-off valve must be closed after the evacuation.

Do not allow the tank to become full. It can lead to paper becoming compacted in the bottom of the tank, making it more difficult to empty.

#### **NOTICE**

Before the boat is laid-up for winter storage, the whole system must be cleaned and flushed thoroughly while the boat is still in the water.

The whole system must be thoroughly drained of water when the boat is lifted out of the water.

This measure prevents frost damage, bacteria growth and smells.

Use of antifreeze is not recommended, since it is impossible to guarantee that it reaches all parts of the system.

### 4.3.3 Heating system

The boat can be equipped with a heating system as an optional equipment.

The heater unit is located port side, midship, under the deck. It is accessible through the hatch from inside the wheelhouse. There are closable heating vents in the wheelhouse aft area and in multicabin.

The operation panel is located in the pilothouse port wall.



**⚠ WARNING**

Appliances that burn fuel, consume oxygen and discharge toxic combustion products into the boat.

Good ventilation is essential when such an appliance is in use. Open ventilation holes and make sure that they are not blocked and that air flows freely through them.

- Never leave the boat unattended when the heater is in use.

**NOTICE**

Heater components may break if the wrong kind of fuel is used. For more information, see the manufacturer’s manual.

- Do not switch off the heater’s direct supply current before you have made sure that the appliance has cooled down.

### 4.3.4 Navigation system

Your boat can be equipped with multifunction displays (MFD).

Depending on the boat configuration, the boat is equipped with single or multiple screens.

The multifunction display can be used to show electronic charts, plot courses, and navigate the boat. It also acts as interface for marine electronics and other digitally enabled equipment on board.

Refer to the supplier’s manuals for complete user instructions and maintenance instructions of these functionalities and equipment.

#### 4.3.4.1 VHF equipment

VHF radio allows instant communication between your boat and other boats, marinas, bridges, and maritime authorities.

The VHF radio is the recommended means of communication on the coastal waters, and it transmits messages on high frequency waves. The VHF system consists of a VHF radio unit near the drivers position and a radio antenna located on the mast of the boat.



Study the provided booklet for the local regulations and the functionalities related to the use of the VHF system.



For your safety, make sure the VHF system is operational before going out to open sea.

### 4.3.5 Bow thruster

The bow thruster enhances the maneuverability of the bow when docking or performing other maneuvers that require increased operator control.

The bow thruster is powered by the Aux battery.

The batteries must be disconnected from the electronic circuit before changing a fuse. For more information, see the manufacturer’s manual.

**⚠ WARNING**

Incorrect use may cause overheating and short circuiting, and pose a fire risk.

- Use the bow thruster for only short periods at a time.
- Do not exceed four duty cycles (max. 30 seconds long in 25 mins).

If overloading occurs, contact a qualified marine electrician.

**⚠ WARNING**

- Do not touch the bow thruster or its fuse if the Aux main switch is switched on.

**⚠ DANGER**

**Pinching hazard**

Never put your hand or any other body part near a windlass or bow roller in operation.

### 4.3.6 Anchor windlass

The boat can be equipped with bow windlass.

#### Operation

To operate the windlass, windlass breaker must be switched on.

Windlass is operated with a momentary switch. Pushing the up button will raise the anchor and pushing the down button will lower the anchor.

If there is a loss of power to the windlass, check the windlass breaker to see if it needs to be reset. If the breaker keeps tripping after it has been reset, the anchor windlass system is recommended to be inspected by a qualified electrician.

The anchor windlasses are powered by the Aux battery. The battery and its fuse are located in the bow of the boat.

**⚠ WARNING**

- Do not touch the anchor windlass or its fuse if the main switch Aux is switched on.
- Even if the current is switched off, do not change the windlass fuse. The high current may cause a fatal electric shock.

#### Manual operation

In case of loss of power, the windlass can be manually operated by disengaging the clutch. Please refer to the manufacturer's manual how to operate the windlass manually.

#### Before using the anchor windlass

Always check that:

- The windlass is in working order.
- The anchor chain can move freely.
- The anchor and the chain cannot damage the boat when lowered.
- The anchor and anchor chain cannot hit any person.

For more information, see the manufacturer's manual.

**While under way**

The anchor windlass must be fixed mechanically to prevent it from coming loose when the boat is moving. For more information, see the manufacturer’s manual.

**⚠ DANGER**

**⚠ WARNING**

**Pinching hazard**

Never put your hand or any other body part near a windlass or bow roller in operation.

**⚠ WARNING**

If the windlass loosens when the boat is moving at great speed, it may cause great damage to the boat, its passengers and outsiders.

- Always fix the anchor windlass mechanically in place before getting under way.

**⚠ WARNING**

- Keep all body parts and clothing away from an activated windlass.

**NOTICE**

- Do not use the windlass to pull or tow another vessel.

**Maintenance**

Salt deposit accumulating on the windlass should be washed away with fresh water regularly to prevent corrosion. For more information, please refer to the manufacturer’s manual.

**4.3.7 Roof racks**

The boat can be equipped with roof racks.

Roof racks allow for transportation of bulkier objects such as kayaks or bicycles. Objects put on the roof racks must be secured tight to prevent them from falling off or damaging the boat’s roof or other components.



Load limit of roof racks is 25 kg / 55 lbs per roof half. Max. load of roof racks is 40 kg / 88 lbs.

## 5 Transportation

### 5.1 Lifting the boat

Lift the boat only with a lifting beam and lifting straps. Use the specified locations for the lifting straps.



Commission only a reputable lifting company or a boatyard with sufficient lifting capacity to lift the boat. Make sure the company has full insurance cover, in case of any damages.

#### DANGER

Risk of serious injury or death by falling load.

- Do not stay under the boat when it is hanging in the crane.

Lift straps may slip on the hull. When appropriate, tie the straps together before lifting.

The position of the straps may need to be adjusted depending on how the boat is loaded.

In addition to the boat's own weight, take into account the equipment and other possible loads in the boat.

#### CAUTION

Note the location of the log transducer to avoid damaging it.

- Protect the hull sides well to avoid damages.

The lifting beam must be exactly the same width as the boat. Always take great precautions near and around the boat when lifting.

#### CAUTION

Risk of damage to the hull.

Do not lift the boat with a forklift.

The location of the lift straps is indicated in the figure.

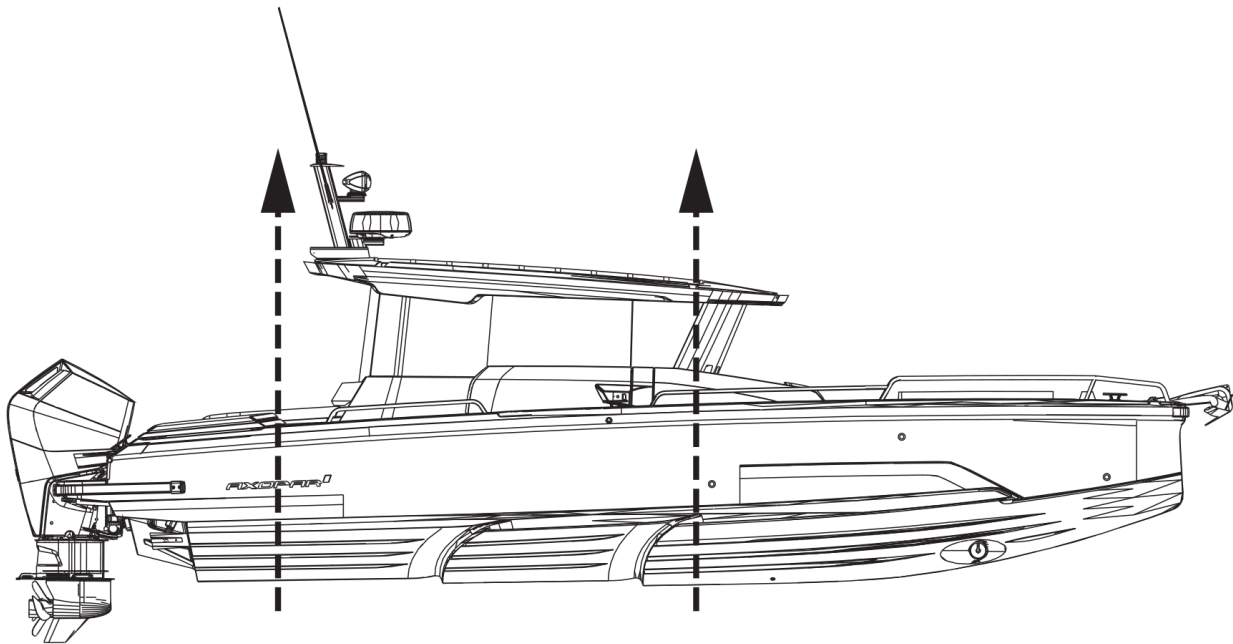

Before operating any lifting equipment:

- Check and determine applicability of federal, state, or local requirements.
- Follow the lift equipment manufacturer's requirements and recommendations.
- Check the boat's lift points, weight and other information.
- Straddle lift operation is a highly technical area that requires trained and experienced operators.

During lifting:

- Check the boat for bilge water before lifting.  
Excessive quantities of bilge water can shift, changing the balance of the load.
- Check for thru-hull appendages such as knot meters and stabilizers, rub, spray, and splash rails, so that they are not damaged by the lifting equipment.
- Check the hull structure to locate shafts, rudders, struts, and the forward and aft ends of any keels.
- Check the hull's structural configuration, including the location of bulkheads, stringers, engines, and tanks.
- Check bilges for water ingress following launch.
- Transport the boat as close to the ground as practicable.

## 5.2 Transporting and storing the boat

Before lifting the boat onto the trailer, make sure that the trailer is suitable for the boat.

Make sure that there is a sufficient number of supports to distribute the weight properly without excessive point loads, and the capacity and dimensions of the trailer are sufficient to carry the boat and its engine,

equipment, battery, boating accessories and fuel on board. Pay special attention to exposed areas and edges of hull, such as strakes and steps in the hull, during loading, deloading and transportation.

**⚠ WARNING**

A boat trailer that does not have sufficient capacity or that is poorly maintained can become damaged and cause a danger on the road.

- Make sure that the trailer capacity is sufficient to also carry the weight of the engine, fuel and equipment.

**⚠ CAUTION**

The hull of the boat can be damaged if there is an insufficient amount of supports on the trailer or during the storage.

The trailer must be a little nose heavy. Make sure that the boat is securely fastened to the trailer, that it cannot move into any direction, and that the side supports provide an even support for the weight of the boat.

Before loading the boat on the trailer:

- Remove any unnecessary weight from the boat.
- Drain the bilge water.
- Adjust the side supports of the trailer so that the most weight rests on the keel supports, and the side supports only offer lateral support.
- Protect the boat by placing suitable padding between the tie down straps and the boat, if necessary.
- See the engine manual for any instructions on trailering.
- Make sure that the doors and hatches are properly closed.
- Pay attention to any equipment and accessories in the boat during trailering.
  - Make sure you secure all loose items in the boat.
  - Do not use a hood, canopy, tonneau cover or other similar top or cover on the boat during trailering.

These hoods and covers can become detached at high speeds and damage the boat and cause a danger to traffic.

A hood or other cover flapping in the wind during trailering can damage the boat surface.

- Keep the hood in its dedicated storage compartment during trailering, or remove the hood completely, if necessary.

## 6 Operation

The boat owner must take local and international regulations into consideration concerning the boat crew, equipment and handling of the boat. In some countries, a driving license or a separate authorization is required for driving the boat. Special regulations may also apply.

Ensure that the anticipated wind and wave conditions do not exceed the design category of the boat, and that the crew is able to handle the boat in these conditions. Even though the boat is designed for such conditions, they can still be very dangerous. Only a capable, fit and trained crew, using a well maintained boat, can satisfactorily operate in such conditions.

If the boat is fitted with a life raft, carefully read its operation manual. Onboard, the boat must have the appropriate safety equipment according to the boat type and weather conditions. This equipment is compulsory in some countries. The crew must be familiar with the use of all safety equipment and the most important actions in different emergency situations. Sailing schools and clubs regularly organize rescue drills.

The equipment in the boat may differ from the equipment used in the figures in this manual. This might be due to any optional equipment chosen or modifications made after producing this manual. In such cases, contact your local dealer for the operation instructions and additional information regarding the operation of the equipment in question.

Always maintain the boat properly and make allowance for the deterioration that occurs over time and as a result of heavy use or misuse of the boat. Any boat, no matter how strong it may be, can be severely damaged if not used properly. Inappropriate use of this boat not compatible with safe boating is not allowed. It is always important to adjust the handling of the boat to the sea conditions and own boating experience. The gelcoat parts, especially the colored parts, need to be polished and waxed approximately every fourth months to prevent the parts from fading or getting other visual defects.

### 6.1 Handling devices

#### 6.1.1 Steering console

The controllers are situated so that the driver can easily manage them from the steering console.

The location and quantity of the devices depend on what optional equipment and engine models have been chosen. See the device manuals for further information on the devices.

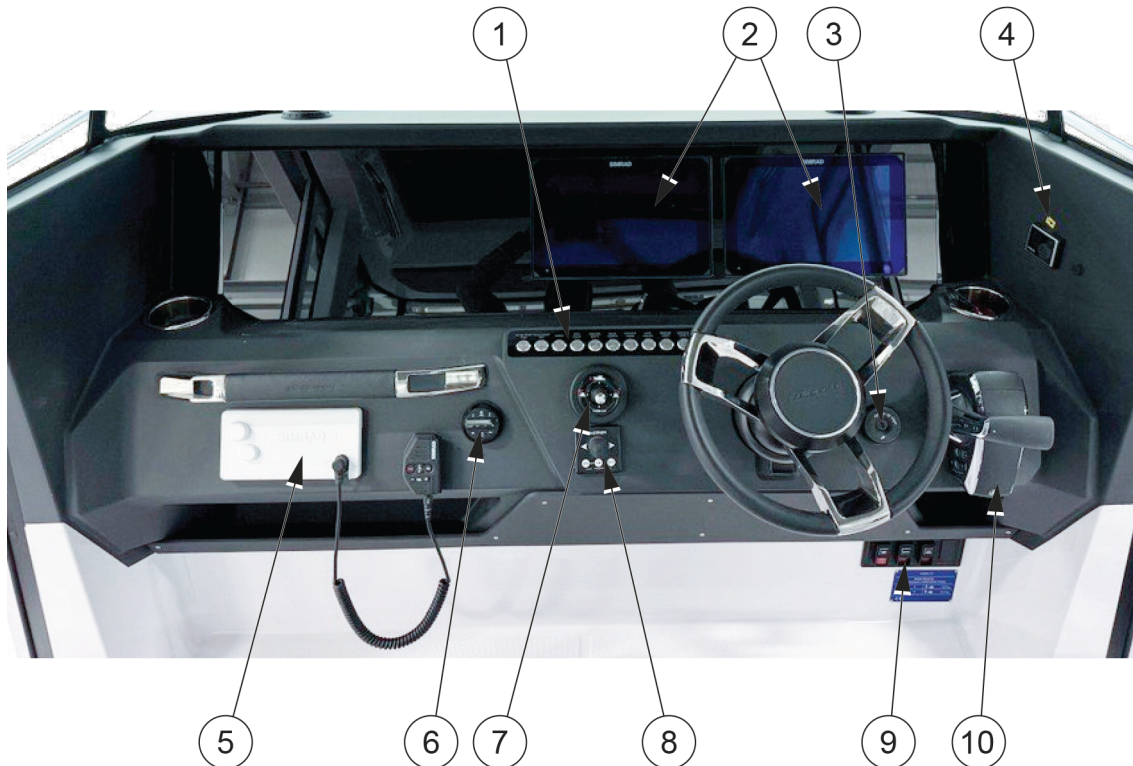

- (1) Steering console switch panel
- (2) Chart plotters (second one optional)
- (3) Ignition key
- (4) Heater control (optional) (Moved to port side)
- (5) VHF radio
- (6) Audio remote (optional)
- (7) Trim tabs control
- (8) Bow thruster control
- (9) Remote main switches
- (10) Engine remote control



## 6.1.2 Steering console switch panel

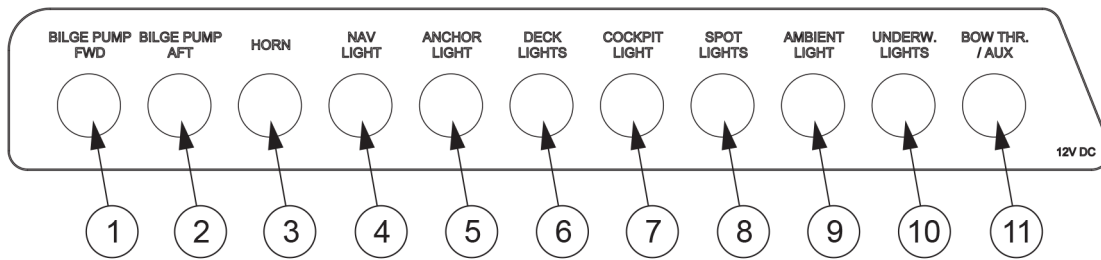

- (1) Bilge pump forward
- (2) Bilge pump aft
- (3) Horn
- (4) Navigation light
- (5) Anchor lights
- (6) Deck lights
- (7) Cockpit light
- (8) Spot lights
- (9) Ambient light
- (10) Underwater light
- (11) Bow thruster / Aux

## 6.1.3 Windscreen wipers

The boat's windscreen wipers are controlled by the switches in the boat's steering console.

## 6.1.4 Steering system

The steering system is one of the most vital systems related to safe boating.

The boats are equipped with a hydraulic steering system with the alternatives of power steering and non-power steering systems. Please refer to the collateral manuals provided by the outboard engine and steering system manufacturer included in the manual package provided with the boat.

The non-power steering system consists of a steering wheel, a helm pump, a hydraulic hosing, and a hydraulic steering cylinder.

The power steering system includes a steering pump to help with the handling of the vessel.

### 6.1.4.1 Checking and topping up oil

Effective and properly working steering is crucial for the safety of the boat.

- Check the oil level in the pump before casting off.
- For detailed instructions and the steering system oil recommendation, see the manufacturer's documentation.

### 6.1.4.2 Steering maintenance

For the regular maintenance of the steering system components, please refer to supplier's manual.

If you encounter issues beyond regular maintenance needs, please contact your boat dealer immediately for service.

### 6.1.5 Throttle lever

The engine throttle and shift are controlled by the electronic throttle lever. To start the engine, the lever must be in the neutral position. The throttle lever is used to control the engine's RPM which affects the speed of the boat.

Moving the lever forward shifts engine into the forward gear, and moving the lever backwards shifts the engine into the reverse gear. Progressively moving the lever in one direction will increase the speed of the boat in that same direction.

For detailed guidelines about safe boating and component maintenance, please refer to the provided outboard engine literature. If you encounter issues beyond regular maintenance needs, or if noticeable failures occur, please contact your boat dealer immediately for service.

#### **WARNING**

Always make sure no one is close to the propeller when starting the engine or engaging the propeller! Acknowledge the information provided on the helm's warning labels.

#### 6.1.5.1 Trim and tilt

The engine can be raised or lowered with the trim controls in the throttle lever.

Raising and lowering the engine is needed when trailering or launching the boat. Adjusting the trim angle of the engine also allows optimizing the run angle for the boat to achieve optimal performance or fuel efficiency.

When raising the engine(s) all the way, make sure the engines are facing straight aft, and no optional equipment such as foldable seats or aft deck gates are in the way.

Refer to the supplier's manuals for detailed operation instructions, maintenance, and warranty information.

#### **WARNING**

Raising the engines out of the water without paying attention to surrounding equipment such as aft deck gates, foldable seats or waterski frame may cause damage to the engines.

### 6.1.6 Starting the engine

See the engine manufacturer's manual for engine information.

1. Set the engine lever in neutral.
2. Turn the ignition on and check the fuel level.
3. Start the engine by turning the ignition key.

4. Check that the gauges for oil pressure and volt meter show normal values.
5. Run the engine to operating temperature at idling speed. Never rev up a cold engine.

**⚠ DANGER**

Risk of carbon monoxide poisoning.

Be aware of the risks with engine exhausts. For example, under turbulence or disadvantageous wind conditions, exhaust can enter the boat. If this happens, avoid idling the engines. If these problems occur under way, do not open the hatches and ventilators, as it can worsen the problems. Instead, you may try solving the problems by changing the boat's speed or weight distribution.

**⚠ WARNING**

Never step onto the swim ladder when the engine is running. Stop the engine while the steering and propeller are being inspected.

**⚠ WARNING**

Do not operate this boat with an engine that exceeds the maximum engine power recommended by the manufacturer.

## 6.2 Swivel seat - Driver and passenger seats

The driver and passenger seats are operated with locking handles.

**⚠ DANGER**

The locking handles must be in the locked position before the boat speed exceed 5 knots.

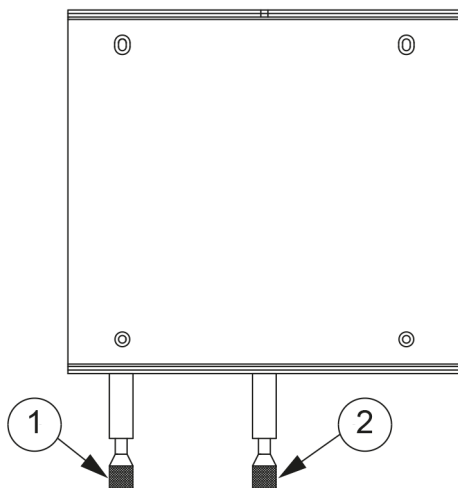

- (1) Rotation locking handle
- (2) Moving locking handle

- For the rotating function, press the locking handle down to release the lock.  
This allows you to rotate the seat on the post.
- For the moving function, lift the locking handle up to release the lock.  
This allows you to move seat from back to front.

## 6.3 Inspecting the boat

Due to safety reasons, the below listed inspections must be carried out before and after using the boat.

### 6.3.1 Checklist: Regular inspection before leaving harbor

#### Safety

Make sure that:

- All the people onboard have life jackets.
- The wind and wave conditions do not exceed the design category of the boat.
- The dead man's switch is switched to driver.
- There is a fire extinguisher (or several) onboard and their approval/inspection date has not expired.
- The needed ropes and anchor are onboard.

#### Draining and tightness

Check that:

- There is no water in the bilge.
- All the bilge pumps are functional.
- The bilge has no signs of fuel or oil leaks.
- All deck hatches are tightly closed.

#### Electrical and engine

Check that:

- All the fuses are intact.
- The main switches are switched on.
- The batteries have enough power.
- The engine works properly.
- The engine cooling water flows as expected.
- The fuel level is sufficient.

#### **WARNING**

The specified tank capacity is not necessarily fully available, depending on the trim and load on board. The tank must always be kept at least 20% full.

### 6.3.2 Checklist: After using the boat

Make sure that:

- The main switches are switched off.
- The septic tank discharge valve is closed.
- There is no water in the bilge.
- The bilge pumps are functional.
- The deck draining works properly and all the draining valves are open.
- All deck hatches, roof canvas and doors are tightly closed.

### 6.3.3 Checklist: After grounding

If the boat hits a rock, the damage may be easily visible or hidden.

- Make sure that everyone on board is wearing a life jacket.
- Check that everyone on board is up on the deck.
- If necessary, make an emergency call or use a distress signaling device.
- Immediately after a capsize, check the bilge for leaks. Even if the bilge pump is not rated for leaks, you may try to empty the boat using it.
- Stop the engines and lift them out of the water.
- Turn off all the main electrical switches.
- If you can detach the boat after a rock slide, check the condition of the engine.
- Inspect the boat for leaks.
- To avoid further damage to the engine, do not drive the boat if, for example, you notice an oil leak or the engine blade is damaged.
- If the leak is small, the boat is detached and at least one of the engines is functioning, drive to the nearest shore to prevent the boat from sinking.
- If a liferaft is available and required, prepare it for use.
- If you detect a leak, close all doors and hatches. Open doors and hatches may cause the boat to drown more quickly.
- Do not go inside of the boat if it has a leak.
- Call for towing assistance from local authorities or other agencies.
- A professional should inspect the boat after grounding. Even if there is no visible leak, the hull may be damaged and in need of repair.

**⚠ WARNING**

A big leak may cause the boat to sink quickly. Do not go or stay in and wear a life jacket.

## 6.4 Handling the boat

### 6.4.1 Checklist: Boat handling before leaving harbor

For safe navigation under all weather conditions, proper sound signaling equipment in compliance with regulations (COLREG, 1972) must be carried on board. Make sure that the sound signaling equipment on the boat is compliant with these regulations.

#### **⚠ CAUTION**

According to national regulations in some countries, it is a legal requirement to wear a life vest at all times.

- Check that the boat and its equipment are in seaworthy condition.
- Always listen to long-term weather forecasts when planning longer trips.
- Always make sure there is enough fuel and freshwater in the tanks.
- Check that all items on board are properly stowed and adequately secured to manage rough sea and wind conditions.
- Make sure that the swim ladder is raised out of the water before moving off.
- Make sure that the steering is correctly positioned before starting.
- All persons on board must wear an appropriate life vest when on deck.

### 6.4.2 Leaving the jetty

Before casting off, consider how to best leave the jetty.

- Check what the wind direction is.
- If the boat has two engines, move away from the jetty by engaging the engine nearer the jetty astern at idling speed and engaging the other engine ahead at idling speed on.
- The boat will swing out from the jetty astern. As the bow will move against the jetty, fend off properly.

With only one engine this can be a little more challenging, especially if the wind is pressing the boat firmly against the jetty, you have to use a spring to get the stern out.

- Firmly fend off the bow from the jetty.
- Take a line from the bow around a bollard or cleat, so that it can be easily let go.
- Engage idling speed ahead and turn the rudder so that the stern glides out from the jetty.
- When the boat has reached a position, where it can safely be reversed, release and retrieve the line, quickly center the rudder and engage astern.

#### **⚠ CAUTION**

Gather in all lines and fenders while you are still in sheltered water. A rope around the propeller can disable a boat.

### 6.4.3 Driving the boat

Going out in a motor boat involves responsibility not just to those on board, but also to others we meet on the water. Showing consideration for others makes boating comfortable. Everyone has the same right to be at sea, whatever kind of boat they go afloat in.

The physical laws that apply to a boat are rather different from, for example, those affecting a car, as are the possibilities of controlling it.

You can influence a boat's behavior and the level of comfort on board primarily by adapting the speed to the prevailing sea conditions and by the intelligent use of the trim tabs. A planing boat rides almost level in the water at maximum speed. As the speed of the boat is reduced the trim angle increases and the bow rises slightly. This is normal, and is a prerequisite for good performance.

#### 6.4.3.1 Dead man's switch

If the boat is equipped with a dead man's switch, attach its lanyard to yourself immediately after detaching the mooring lines. For more detailed instructions, see the engine manual.

It is very important that the boat stops if you for some reason fall overboard or stumble on board, particularly if you are alone. However, remember to detach the lanyard from your wrist before docking or beaching operations to prevent the engine from stopping unintentionally.

#### 6.4.3.2 Driving at high speed

Although the boats have passed the CE requirements for swerve tests at full speed, Axopar Boats does not recommend making sharp turns at high speed. When exceeding a certain speed limit any hull construction might lose its grip. This might lead to passengers hurtling out of the boat, especially in a single engine configuration.

- Do not use the boat if it has an engine with a higher power rating than indicated on the capacity plate.
- Do not drive the boat at high speed if the engine's rig angle is negative (bow down).
- Do not drive at full speed on congested waterways or if the visibility is limited because of weather conditions or waves.
- Reduce your speed and wake as a matter of courtesy, and also for the safety of yourself and others.
- Observe and obey speed limits and prohibitions associated with a swell.
- Follow the rules of navigation and the requirements of COLREG (Convention on the International Regulations for Preventing Collisions at Sea).
- Always make sure that you have the space needed for avoiding collisions and coming to a halt and for evasive maneuvers.
- Always use a dead man's switch if available.
- Reduce speed in high seas for increased comfort and safety.
- Learn the boat's speed potential. Utilize this knowledge for economical and safe cruising.
- Avoid using high speed along with large rudder movements when going astern, because that places great strain on the rudder and steering mechanism.
- Avoid sudden steering maneuvers at high speeds.
- Avoid staying in the bow area when driving at high speeds.

Avoid sudden changes in travel direction at high speed. Let the boat come to a stop, and the engine rev down before shifting between forward and reverse. Otherwise excessive strain is put on the engine, which could cause the engine to stop. In the worst case, sea water may enter the engine.

A right-handed propeller rotates clockwise and a left-handed propeller anti-clockwise, seen from the stern. The rotation of the propeller is critical for steering the boat. The right-handed propeller pushes the stern of the boat to starboard when the engine is engaged ahead and to port when it is going astern. The direction of rotation of the propeller has a major impact on the turning radius. A right-handed propeller gives a smaller turning radius to port than to starboard. This is called the propeller's paddlewheel effect.

The boat's propellers have considerable propulsion power that provides powerful acceleration. Take this into consideration to avoid dangerous situations arising from this.

**⚠ DANGER**

A revolving propeller is life-threatening to a swimmer or a person who has fallen overboard.

Use the dead man's switch and turn off the engine when someone is climbing on board.

### 6.4.3.3 Driving in rough seas

Never go out in rough seas, if you are uncertain whether the boat and those on board can cope. Follow these simple rules.

- Be well prepared.
- Remember to secure loose equipment.
- Always have a sea anchor and other emergency equipment easily accessible.
- Avoid breaking seas that can appear close to land and over shallows.
- If there are significant waves, always reduce speed to guarantee the safety of the persons on board.
- Use the trim tab to trim the bow down to reduce hull slamming in a head sea.

#### In a head sea

- Adjust speed to suit the size of the waves.
- Adjust the trim angle to the size of the waves. Avoid taking seas beam on.

#### In a following sea

Remember to keep the bow high in a following sea. Avoid crashing through waves, maintain low speed. If necessary, deploy the sea anchor to reduce speed.

Planing boats can be particularly exposed in rough following seas. The stern of the boat rises and the rudder does not answer, so the boat broaches while the bow cuts down into the sea.

### 6.4.3.4 Maneuvering in narrow channels

When maneuvering the boat in narrow channels, the engine speed must be kept as low as possible so that maneuvers are calm and steady.

In difficult wind and current conditions, more revs might be necessary to make full use of the power of the engine. In these conditions, it is important that maneuvers are made quickly and precisely to prevent the boat from drifting into trouble for example.



A good rule before starting a maneuver under difficult conditions, is to think through the different situations which could arise. Pay attention to the wind and current conditions and decide in advance which maneuver you will make. It is also important to brief crew members on what they need to do in different situations.

Always keep in mind that the stability of the boat may be reduced when towing.

**⚠ CAUTION**

Even a nonslip molding can be slippery to walk on when the deck is wet.

### 6.4.4 Visibility from steering position

The International Regulations for Preventing Collisions at Sea (COLREG) demand that a proper lookout is kept at all times, and the *right of way* rule is followed.

The following factors can considerably reduce visibility, among other things:

- Gear trim angle
- Trim tab angle
- Load and load position
- Speed
- Rapid acceleration
- Changeover from displacement speed to planing
- Sea conditions
- Rain and thunderstorms
- Darkness and fog
- Inner lighting when under way in the dark
- Position of curtains
- People and equipment that block the driver's view.

**⚠ WARNING**

Make only small adjustments at a time. Holding down the button for the trim tab for any length of time can result in partial loss of control of the boat.

### 6.4.5 Using the trim tabs

A boat does not need trim tabs to get up on the plane or to give good performance. However, trim tabs are a very useful aid when used correctly.

There are two situations in particular where the trim tabs need to be used:

- When it is desirable to trim the bow down in a rising sea and at speeds between going up planing and cruising speed.
- When running with a strong beam wind.

A planing boat always leans into a strong side wind. This reduces the boat's seakeeping qualities, which is why listing to one side needs to be eliminated as far as possible. Lowering the trim tab on the windward side brings the boat back into normal attitude.

For trimming the bow down, both trim tabs are used in parallel. Begin by retracting both trim tabs completely, then lower both of them a little at a time, so that you retain complete control over how the boat is affected. When running with a following sea, both trim tabs always need to be fully raised. The reason for this is that boats have a tendency to “dive” in a strong following sea, which can result in uncontrollable slowing. Therefore you must run the boat with a high bow angle in a following sea.

## 6.5 Preventing falling overboard

The boat’s working decks are areas where people can move about when the boat is being maneuvered. The working deck area is shown in grey in the figure.

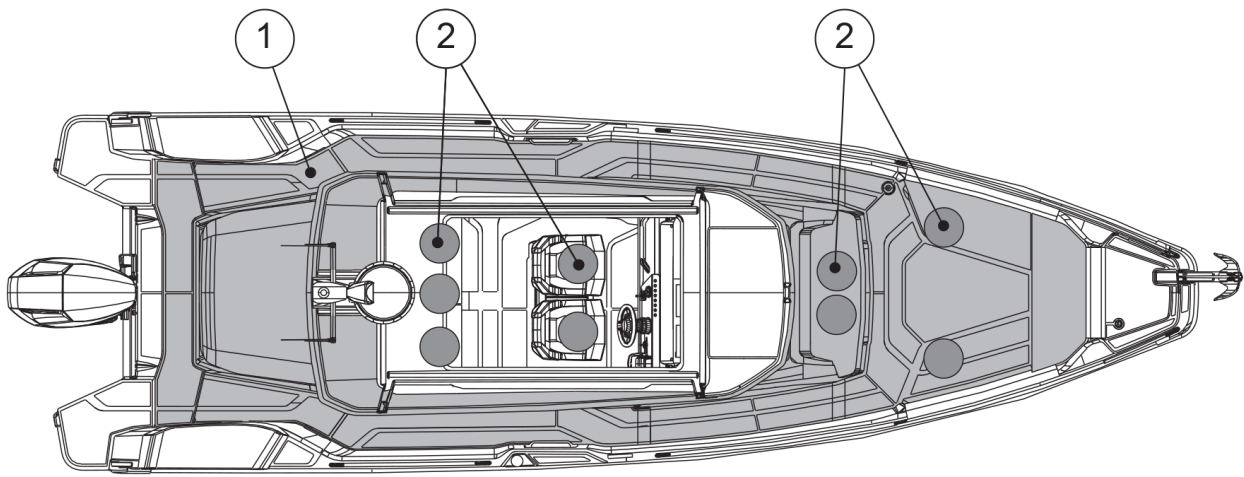

- (1) Working deck area
- (2) Seats

Do not sit, stand or spend time in other parts of the boat while the boat is under way.

Moving about in the aft part of the aft deck and on the front deck while the boat is under way is not recommended.

If a person has fallen into the water, the easiest way to get back on board is to use the swim ladder. The ladder can be pulled down also from the water.

### Staying on deck

**⚠ WARNING**

Staying in the bow of the boat is not recommended in speeds exceeding 30 knots.

**⚠ DANGER**

A revolving propeller is life-threatening to a swimmer or a person who has fallen overboard.

- Use the dead man’s switch.
- Turn off the engine when someone is climbing on board.



If the sun deck cushions or the front deck table are in place, observe the maximum speed of 15 knots to avoid the cushions or table detaching at speed or in high waves.

## 6.6 Anchoring, docking and mooring

### 6.6.1 Fastening points

Fastening points (or cleats) are located both at the stern, midship and bow.

- When anchoring or towing, the forward force is 32.2 kN.
- When mooring the forward force is 26.3 kN.
- When mooring the rearward force is 22.5 kN.

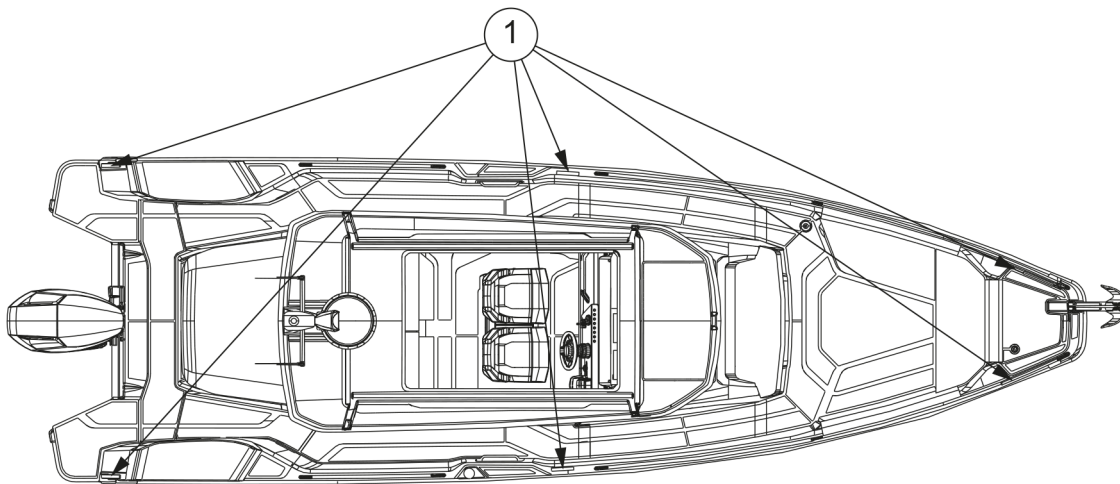

(1) Fastening points

**⚠ CAUTION**

The breaking strength of lines shall in general not exceed 80% of the breaking strength of the fastening points.

### 6.6.2 Docking

Always brief your crew how you are planning to dock. Fenders and at least one mooring line fore and aft must be in place before approaching the jetty.

It is always easiest to dock against the wind. Try to hold the bow exactly into the wind and maintain sufficient speed for the boat to answer the rudder. If the bow is blown off in one direction, back out and repeat the maneuver. Bring the bow up to the jetty, and make sure you get a line ashore quickly.

Docking with a side wind is a little more difficult. Do not steer parallel to the jetty letting the boat blow in as there is always a risk of the bow being blown off towards other boats or the jetty. Instead, try to maneuver the boat so that the wind comes directly from astern. Then the boat can be maneuvered straight ahead since the wind helps hold the boat on a straight course. It is good to have

someone on the foredeck that can go ashore and quickly turn the bow in the desired direction after the boat has stopped completely.

Try to always avoid sharp movements of the throttle, since idling speed in ahead and astern is generally adequate. Sharp movements of the throttle can lead to panic maneuvers.

**⚠ CAUTION**

The tensile strength of the lines or chains should normally not exceed the strength of the fastening point in question.

### 6.6.3 Checklist: Before anchoring

1. Check the chart to see if anchoring is permitted in the area.
2. Listen to the weather forecast for the area and take note of the expected wind conditions.
3. Switch on the echo sounder.
4. Study the seabed conditions and make sure that there is good holding ground.
5. Check that the safety chain has been released from the anchor.
6. Wait until you have reached the intended anchoring point before lowering the anchor.
7. Let out the anchor line equal to at least three times the depth of the water.
8. Put the engine in astern to check that the anchor has taken hold (only when bow anchoring).
9. Note your position on the GPS. Regularly check that the boat has not moved from its position.
10. Set the echo sounder to "Anchor Watch".

**⚠ WARNING**

Always fix the anchor in such a way that it is securely fastened onto the boat. An anchor that falls off when under way may cause serious damage to the boat and mortal danger to the crew.

### 6.6.4 Towing and mooring

**⚠ CAUTION**

When towing another boat or being towed, always drive slowly. If the boat you are towing is of the displacement hull type, never exceed its hull speed.

- Always attach the tow line so that it can be detached under load. It is the owner's and users' responsibility to ensure that the mooring lines, towing lines, anchor chains, anchor lines and anchors are adequate for the vessel's intended use.
- Always remember that the stability of the boat may decrease when being towed.

## 7 Maintenance

### 7.1 Cleaning and maintaining the gelcoat surface

The gelcoat surface of the boat is subjected to environmental conditions which can, under certain circumstances, lead to deterioration of the surface. Overtime, these external factors such as saltwater, high UV exposure and temperature variation, can have an effect on the gelcoat surface.

Generally, gelcoat should last 3 years without showing any significant signs of yellowing, chalking, or other deterioration in typical conditions.

#### NOTICE

Clean and maintain regularly all the gelcoat surfaces on the boat.

If the regular cleaning and maintenance is neglected, or if the boat is exposed to certain environmental conditions where it is berthed, deterioration of the surface finish such as fading, discoloration and brittles may become visible over time.

- Wash and clean the boat after every trip, and weekly if it is stored outside uncovered.
- Wax the boat twice a year if used all year, otherwise annually.
- Inspect the gelcoat surface annually for signs of deterioration, such as brittle surfaces or changed color tones.
- Small scratches or discolorations can be fixed by buffing or polishing.
- Severe scratches, discoloration or oxidation may require wet sanding before buffing, polishing and waxing.

Wet sanding is recommended to be performed by an Axopar dealer or a trained professional.

- When the boat is not in use, keep the gelcoat surface out of the sun or cover the boat with a canvas tarpaulin.

Do not use plastic or other non-porous materials, which can trap moisture between the cover and the surface.

#### Washing

#### NOTICE

Use a cleaning product specially made for boats. Do not use household cleaning products, chlorine, acids or similar as they may damage the boat surface due to their improper pH value.

Wash the boat after every trip by using a mild cleaning product. Dilute the cleaning product with fresh water according to the instructions on the product label.

1. Rinse the deck and hull with fresh water to remove loose dirt.
2. Wash the surfaces with the diluted cleaning product and a soft-bristled brush.
3. Rinse off with fresh water.

#### Waxing

Waxing the gelcoat surface restores gloss and protects the finish. Only use wax recommended for gelcoat, and follow the product instructions carefully.

Wax can either be applied by hand using a clean rag, or with an orbital-motion buffing machine.

**NOTICE**

If using a buffing machine, do not exceed the speed of 1200 rpm. Using a higher speed may burn the gelcoat.

**NOTICE**

Do not wax a gelcoat surface in direct sunlight.

1. Apply wax and wait for a few minutes until the wax looks dry.
2. Buff the wax either by hand using a clean rag, or by using a buffing machine.  
Buff in circular motions until the surface is clean and glossy.
3. Finish by wiping the potential wax residues off with a clean rag.

**Polishing and buffing**

Small scratches or discolorations can be fixed by polishing and buffing the boat. If the surface has severe discoloration or oxidation, wet sanding is recommended before polishing and buffing.

- Polishing compounds remove small scratches and discolorations.
- Buffing compounds contain abrasive and remove deeper scratches or oxidation.  
Buffing compounds can be used, for example, to remove scratches on the hull caused by the fenders.
- After using the buffing compound, use polishing compound to achieve the best possible finish.
- Follow the product instructions of the compound carefully.

Polishing and buffing compounds can either be applied by hand using a clean rag, or with an orbital-motion buffing machine with a polishing pad.

**NOTICE**

When using a buffing machine, do not exceed the speed of 1200 rpm. Using a higher speed may burn the gelcoat.

**NOTICE**

Do not polish or buff a gelcoat surface in direct sunlight.

1. Apply polishing or buffing compound on the surface and wait for a few minutes until the compound looks dry.
2. Polish or buff the compound either by hand using a clean rag, or by using a buffing machine with a polishing pad.  
Buff in circular motions until the surface is glossy.
3. Wax the surface.

**Wet sanding**

**NOTICE**

Wet sanding is recommended to be performed by an Axopar dealer or a trained professional.

Severe scratches, discoloration or oxidation of the gelcoat surface may require wet sanding. Wet sanding can be done either by hand or by using a machine.

**NOTICE**

When using a machine, do not exceed the speed of 1200 rpm.  
Using a higher speed may burn the gelcoat.

**NOTICE**

Do not wet sand a gelcoat surface in direct sunlight.

1. Spray water to the area that needs to be sanded.

**NOTICE**

Keep the surface continuously moist while sanding.

2. Sand the surface with a 1000 grit sandpaper (for example Mirka Abralon).  
If you use a machine, use a low rpm speed to get the best result.  
Keep sanding until the entire surface is equally matt.
3. Sand the surface with a finer 1400 grit sandpaper.
4. Sand the surface once more with an even finer-grit sandpaper.  
This saves time in the buffing and polishing stage.
5. After sanding, when the surface looks equally matt, rinse the surface with fresh water and allow to dry.
6. Buff and polish the surface to get the gloss back.
7. Wax the surface.

## 7.2 Antifouling

Painting your boat's hull with antifouling paint is worth considering if your boat is most of the season in water.

Boats that are frequently lifted out of the water and relaunched during the boating season can be affected by antifouling oxidization. Out-of-the water, antifouling paint will oxidize, which will prevent the biocide release and slowly cause antifouling to lose its effectiveness. Follow the paint manufacturer's specifications for launching window.

Antifouling wears gradually over time, depending on factors such as the location where the boat is used and how often the boat is used. As a rule of thumb, antifouling lasts one season once applied. When the antifouling needs to be repainted, it is important to use the same antifouling paint as the existing antifoul, or to scrub off old antifouling paint down to gel coat. If different antifouling paints are used, there is a risk that the composition of the paints are incompatible, preventing the antifouling paint from working.

Contact your nearest Axopar dealer in antifouling repainting and condition inspection related matters.

## 7.3 Maintaining the interiors

### 7.3.1 Wooden interiors

The interior details of the boat, such as the locker doors and drawer fronts and wooden strips, are made of oiled wood.

- Clean the wooden interior details with a damp cloth and a small amount of soapy water.
- Treat the wooden surfaces again every year to protect the wood.

### 7.3.2 Plastic and painted surfaces

1. Wet the surface evenly with water before the actual cleaning.
2. Remove stains.
  - Remove regular stains with a brush and a lightly diluted cleaner.
  - Remove grease with a brush or a sponge and window cleaner.
3. Clean the surface afterwards with sponge and water.
4. Wipe dry with a piece of cloth.

### 7.3.3 Fabrics

The interior fabrics are washed according to separate washing instructions (marking on the fabric).

In case the marking is not visible:

1. Wash in 40°C with a light spin cycle.
2. Hang to drip dry.

The material may slightly shrink. If you want to avoid shrinking, take the fabrics to a dry cleaner.

### 7.3.4 Doors and hatches

- Clean the tracks of sliding doors and hatches regularly and lubricate, if necessary.
- Lubricate handles and locks with regular lock lubricant.

## 7.4 Maintaining the cover



New covers may leak initially, as the seams need to swell.

### During use

To prevent quick deterioration of the cover, secure it tightly in a folded-up position to prevent flapping.



**After use****NOTICE**

- Hang to dry. Never use a drying cabinet or iron to speed up drying.
- Check that the cover is completely dry before stowing. Stowing a moist cover can cause mold damage.
- Store the cover in dry indoor conditions for the winter.
- The cover must not be stored in the boat.

### 7.4.1 Cleaning the cover

The cover needs to be thoroughly cleaned two or three times a year.

**NOTICE**

Never use high pressure washers or chemical cleaning agents.

1. Let the fabric cover soak for at least 24 hours.
2. After soaking, wash the inside and outside of the cover with a sponge or a soft brush.  
Use mild soapy water and plenty of water, max. 30°C.
3. Rinse thoroughly with freshwater.  
Mix 12% vinegar in the final rinsing water to neutralize the soap residues.
4. Hang the cover to drip dry.

## 7.5 Protecting underwater metal parts

Boat's underwater metal components, such as thru-hulls, seacocks, trim tabs, engine internal components and propellers, are subject to electrolytic corrosion. Electrolysis and galvanic corrosion (corrosion of dissimilar metals in salt water) can occur in marine environment due to external factors such as stray currents, polluted waters, or proximity of other vessels. It is important for boat owner to be aware of the phenomena, as they can cause serious deterioration over time.

Signs of electrolytic corrosion are, for example, white, powdery substance on exposed metal such as propellers or breakers, or thru-hulls and seacocks turning greenish. If the corrosion has progressed far, even deep pitting can appear on the part's surface.

The boats are equipped with sacrificial anodes to protect the metal parts from galvanic corrosion. Additionally, boats equipped with shore power have galvanic isolators to stop low voltage currents from flowing through the boat.

All underwater metal parts need to be inspected annually for signs of corrosion. Additionally, underwater thru-hulls and seacocks are recommended to be replaced every 5 years. Please refer to chapter [Preventing corrosion](#) for more details.

## 7.6 Preventing corrosion

Sacrificial anodes are installed on the boat's trim tabs and engines to protect metallic parts from corrosion damage. The anodes need to be replaced regularly as they wear out to protect other metallic parts.

- Inspect the anodes monthly.
- Replace them when approximately fifty percent of the anode has deteriorated.

In general, anodes need replacement once a year in fresh water, and more frequently in saltwater environment. If there is an increase in the consumption speed, it can be a sign of electrical issue and the root cause should be investigated.

## 7.7 Preventing frost damage

- The bilge pump system is fitted with a water lock on the hose.
  - Detach the hose and fully drain the water from the water lock and run the pumps dry. Otherwise the pumps may freeze and break.
- Unscrew the frost plug on the underside of the shower fittings.
  - If there is no frost plug, unscrew the shower hose.
- Drain the water tank and all other components containing water in order to avoid frost damage.
- Run the freshwater pump dry to drain out all the water.
- Make sure that no water remains in the boat under any circumstances. Leave the hatches in the cabin partially open.

## 7.8 Checklist: Before winter lay-up

- Wash the hull and bottom immediately after lifting the vessel out of the water.
- Wash all parts inside, also under the floorboards.
- Leave all lockers, drawers, and cabin and wardrobe doors open.
- Remove the carpets.
  - Store the carpets and cushions indoors in a dry place.
  - If this is not possible, make sure that the cushions are dry and position them on their side.
- Disconnect and service the fridge.
  - Switch off the power and disconnect the power supply.
  - Defrost the fridge.
  - Clean and dry the exterior and the interior of the fridge.
  - Empty and dry the condensate water tray.
  - Leave the door slightly ajar to enable ventilation.
  - Check the more detailed instruction in the manufacturer's manual.
- Ensure good ventilation in the boat.
- Make sure that there is no water beneath the fuel tank. Any water present can be extracted using the suction pipe that is attached to the tank's exterior.

**NOTICE**

If the batteries are left aboard, make sure they are fully charged, otherwise the batteries can freeze and crack.

## 7.9 Checklist: Before launching

1. Remove the tarpaulin in good time before launching.
2. Wash the hull with a regular shampoo and a soft brush.
3. Wax the hull, if necessary.  
Use a standard boat wax.
4. If there are small scratches on the hull or if some of the surface gelcoat has lost its shine, use a rubbing compound on these areas before polishing.
5. Paint the bottom with antifouling paint.
6. If the batteries have been removed, put them back and check the electrolyte level in the cells.  
Check the condition of the batteries.
7. Check all cables, clamps, engine mountings and other fastenings.
8. Check the steering before launching.
9. Check the instrumentation.
10. Close all water drain plugs.
11. Check that the seacocks are tight and in order, check for any frost damage.
12. Check all pipes, hoses and cocks.
13. Make a note of any frost damage.

## 7.10 Corrective maintenance

### 7.10.1 Deposits

Mild detergents and fine rubbing compounds reduce the weathering and calcium deposits accumulated on the surfaces.

**NOTICE**

Do not apply the rubbing compound in direct sunlight.

- Use only a fine grit compound, and follow the label instructions carefully.
- For the best result, wax the surface after treating it with the rubbing compound.

### 7.10.2 Scratches and nicks

Most scratches and nicks can be removed by using a rubbing compound followed by waxing.

### 7.10.3 Stains

Most stains can be removed by washing with a mild detergent.

- For stubborn stains, use a fine abrasive household cleanser followed by waxing to restore original luster.
- For non-water-soluble stains, such as grease, oil, and rubber heel marks, use a solvent such as acetone, rubbing alcohol, toluene or xylene, followed by a mild detergent.
  - If these solvents are not effective, try a rubbing compound or fine sanding followed by waxing.

### 7.10.4 Deep marks, gouges and holes

Deep marks, gouges and holes should be repaired professionally.

Gelcoats can be well repaired by professionals, and in most cases the repair will be undetectable.

#### **NOTICE**

In cases where the damage has pierced the gelcoat layer, further exposure to water or chemicals should be avoided.

Failure to observe this precaution may result in extensive and potentially costly damage to the underlying laminate structure.

## 8 Environment

When handling environmentally hazardous substances such as fuel, oils, solvents, grease, bottom coats, you need to consider the following:

- Always read the instructions for each product carefully and handle the product with care.
  - Make sure that the used packaging, cans and similar items are discarded in designated collection points.
  - If you are in any doubt whether the product is hazardous or not, contact the supplier or vendor of the product.
- The backwash from boats wears down the shoreline and creates problems for other boats near you.
  - Always adjust your speed to the situation and the surroundings to avoid unnecessary backwash.
- Always drive the boat at the most economical engine revs possible, taking the prevailing conditions into account, to avoid unnecessary emissions and noise.
- Make sure that the engine is properly serviced at regular intervals so that noise and emission levels are minimized.
  - Read the engine manufacturer's manual carefully.
- As a boat owner you must be aware of the local environmental laws, and respect codes of good practice.
  - Never empty the septic or black water tank into water.
  - Familiarize yourself with the international regulations on the prevention of marine pollution (MARPOL) and comply with these regulations.
- Always investigate the source of any oil leaks as soon as possible.
- Dispose of recovered spilt oil correctly.
- Keep oil-absorbing cloths or rolls on board.
- Never dispose of overboard any oil, paint or other chemical that is potentially harmful to the environment. Sanctions are in place in most parts of the world for those who disregard this rule!

**⚠ WARNING**

Any oil must be treated as chemical waste.

### 8.1 Requirements for North America

The EPA standards state that in freshwater lakes, freshwater reservoirs or other freshwater impoundments whose inlets or outlets are such as to prevent the ingress or egress by vessel traffic subject to this regulation, or in rivers not capable of navigation by interstate vessel traffic subject to this regulation, marine sanitation devices certified by the U.S. Coast Guard installed on all vessels shall be designed and operated to prevent the overboard discharge of sewage, treated or untreated, or of any waste derived from sewage.

The EPA standards further state that this shall not be construed to prohibit the carriage of Coast Guard-certified flow-through treatment devices which have been secured so as to prevent such discharges. They also state that waters where a Coast Guard-certified marine sanitation device permitting discharge is allowed include coastal waters and estuaries, the Great Lakes and interconnected waterways,

freshwater lakes and impoundments accessible through locks, and other flowing waters that are navigable interstate by vessels subject to this regulation (40 CFR 140.3).

## 9 Appendix I: Checklists

### 9.1 Checklist: Fire in the engine

- Stop the engine.
- Steer the boat up against the wind, if possible.
- Make sure all passengers have life jackets.
- If necessary:
  - Evacuate the passengers.
  - Call for sea rescue.
- Extinguish the fire.
- Wait until fully certain that the fire has been extinguished before opening the engine cover.  
Carefully open the engine cover and be prepared to use the handheld fire extinguisher if necessary for post-fire extinguishing.
- Put out possible smoldering fires with water.

### 9.2 Checklist: After fire

- Open doors and windows for better ventilation.
- Inspect the boat and its equipment, and repair any damages.
- Contact local authorities, if needed.
- Make sure that the fire extinguishing equipment is refilled or replaced after use.

### 9.3 Checklist: After grounding

If the boat hits a rock, the damage may be easily visible or hidden.

- Make sure that everyone on board is wearing a life jacket.
- Check that everyone on board is up on the deck.
- If necessary, make an emergency call or use a distress signaling device.
- Immediately after a capsize, check the bilge for leaks. Even if the bilge pump is not rated for leaks, you may try to empty the boat using it.
- Stop the engines and lift them out of the water.
- Turn off all the main electrical switches.
- If you can detach the boat after a rock slide, check the condition of the engine.
- Inspect the boat for leaks.
- To avoid further damage to the engine, do not drive the boat if, for example, you notice an oil leak or the engine blade is damaged.
- If the leak is small, the boat is detached and at least one of the engines is functioning, drive to the nearest shore to prevent the boat from sinking.

- If a liferaft is available and required, prepare it for use.
- If you detect a leak, close all doors and hatches. Open doors and hatches may cause the boat to drown more quickly.
- Do not go inside of the boat if it has a leak.
- Call for towing assistance from local authorities or other agencies.
- A professional should inspect the boat after grounding. Even if there is no visible leak, the hull may be damaged and in need of repair.

**⚠ WARNING**

A big leak may cause the boat to sink quickly. Do not go or stay in and wear a life jacket.

## 9.4 Checklist: Regular inspection before leaving harbor

### Safety

Make sure that:

- All the people onboard have life jackets.
- The wind and wave conditions do not exceed the design category of the boat.
- The dead man's switch is switched to driver.
- There is a fire extinguisher (or several) onboard and their approval/inspection date has not expired.
- The needed ropes and anchor are onboard.

### Draining and tightness

Check that:

- There is no water in the bilge.
- All the bilge pumps are functional.
- The bilge has no signs of fuel or oil leaks.
- All deck hatches are tightly closed.

### Electrical and engine

Check that:

- All the fuses are intact.
- The main switches are switched on.
- The batteries have enough power.
- The engine works properly.
- The engine cooling water flows as expected.
- The fuel level is sufficient.

**⚠ WARNING**

The specified tank capacity is not necessarily fully available, depending on the trim and load on board. The tank must always be kept at least 20% full.



## 9.5 Checklist: After using the boat

Make sure that:

- The main switches are switched off.
- The septic tank discharge valve is closed.
- There is no water in the bilge.
- The bilge pumps are functional.
- The deck draining works properly and all the draining valves are open.
- All deck hatches, roof canvas and doors are tightly closed.

## 9.6 Checklist: Boat handling before leaving harbor

For safe navigation under all weather conditions, proper sound signaling equipment in compliance with regulations (COLREG, 1972) must be carried on board. Make sure that the sound signaling equipment on the boat is compliant with these regulations.

### **⚠ CAUTION**

According to national regulations in some countries, it is a legal requirement to wear a life vest at all times.

- Check that the boat and its equipment are in seaworthy condition.
- Always listen to long-term weather forecasts when planning longer trips.
- Always make sure there is enough fuel and freshwater in the tanks.
- Check that all items on board are properly stowed and adequately secured to manage rough sea and wind conditions.
- Make sure that the swim ladder is raised out of the water before moving off.
- Make sure that the steering is correctly positioned before starting.
- All persons on board must wear an appropriate life vest when on deck.

## 9.7 Checklist: Before anchoring

1. Check the chart to see if anchoring is permitted in the area.
2. Listen to the weather forecast for the area and take note of the expected wind conditions.
3. Switch on the echo sounder.
4. Study the seabed conditions and make sure that there is good holding ground.
5. Check that the safety chain has been released from the anchor.
6. Wait until you have reached the intended anchoring point before lowering the anchor.
7. Let out the anchor line equal to at least three times the depth of the water.
8. Put the engine in astern to check that the anchor has taken hold (only when bow anchoring).

9. Note your position on the GPS. Regularly check that the boat has not moved from its position.
10. Set the echo sounder to “Anchor Watch”.

**⚠ WARNING**

Always fix the anchor in such a way that it is securely fastened onto the boat. An anchor that falls off when under way may cause serious damage to the boat and mortal danger to the crew.

## 9.8 Checklist: Before winter lay-up

- Wash the hull and bottom immediately after lifting the vessel out of the water.
- Wash all parts inside, also under the floorboards.
- Leave all lockers, drawers, and cabin and wardrobe doors open.
- Remove the carpets.
  - Store the carpets and cushions indoors in a dry place.
  - If this is not possible, make sure that the cushions are dry and position them on their side.
- Disconnect and service the fridge.
  - Switch off the power and disconnect the power supply.
  - Defrost the fridge.
  - Clean and dry the exterior and the interior of the fridge.
  - Empty and dry the condensate water tray.
  - Leave the door slightly ajar to enable ventilation.
  - Check the more detailed instruction in the manufacturer's manual.
- Ensure good ventilation in the boat.
- Make sure that there is no water beneath the fuel tank. Any water present can be extracted using the suction pipe that is attached to the tank's exterior.

**NOTICE**

If the batteries are left aboard, make sure they are fully charged, otherwise the batteries can freeze and crack.

## 9.9 Checklist: Before launching

1. Remove the tarpaulin in good time before launching.
2. Wash the hull with a regular shampoo and a soft brush.
3. Wax the hull, if necessary.  
Use a standard boat wax.
4. If there are small scratches on the hull or if some of the surface gelcoat has lost its shine, use a rubbing compound on these areas before polishing.
5. Paint the bottom with antifouling paint.

6. If the batteries have been removed, put them back and check the electrolyte level in the cells.  
Check the condition of the batteries.
7. Check all cables, clamps, engine mountings and other fastenings.
8. Check the steering before launching.
9. Check the instrumentation.
10. Close all water drain plugs.
11. Check that the seacocks are tight and in order, check for any frost damage.
12. Check all pipes, hoses and cocks.
13. Make a note of any frost damage.

# 10 Appendix II: Fuel system

## 10.1 Fuel system: EU

# Neoprene strips on tank

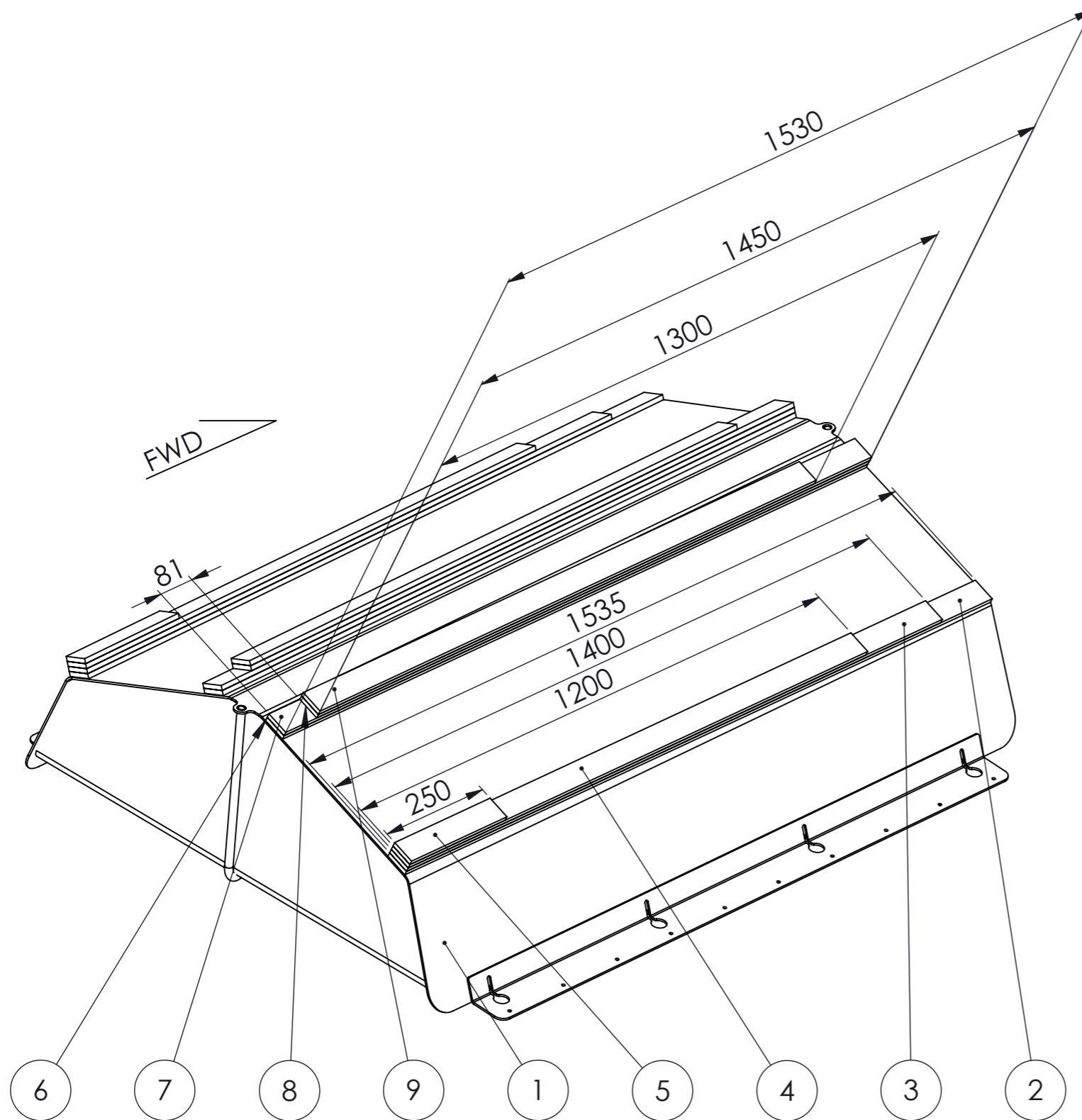

REVISIONS			
REV.	DESCRIPTION	DATE	APPROVED
A	Removed fuel filter and 2x fittings from structure	18.10.2023.	AJu
B	Changed deck filler	7.12.2023.	

Total length of AXO3000305 Neoprene strips: 20,39m ~ 21m

PART NO.	ITEM	DESCRIPTION	MATERIAL	SIZE, CAPACITY	LENGTH (mm)	QTY.
1	AXO8000383, A	FUEL TANK	ALUMINIUM		-	1
2	AXO3000305, A	GASKET	PLASTIC, PE	50 X 10, 60KG / M3	1535	2
3	AXO3000305, A	GASKET	PLASTIC, PE	50 X 10, 60KG / M3	1400	1
4	AXO3000305, A	GASKET	PLASTIC, PE	50 X 10, 60KG / M3	1200	1
5	AXO3000305, A	GASKET	PLASTIC, PE	50 X 10, 60KG / M3	250	1
6	AXO3000305, A	GASKET	PLASTIC, PE	50 X 10, 60KG / M3	1530	1
7	AXO3000305, A	GASKET	PLASTIC, PE	50 X 10, 60KG / M3	1530	1
8	AXO3000305, A	GASKET	PLASTIC, PE	50 X 10, 60KG / M3	1450	1
9	AXO3000305, A	GASKET	PLASTIC, PE	50 X 10, 60KG / M3	1300	1

This document and the information contained in it is proprietary and confidential information of Axopar Boats Oy. Neither this document nor any of the information contained herein may be reproduced, disclosed to others, or used for any purpose other than for the purpose it has been provided without the prior written permission of Axopar Boats Oy.

<b>AXOPAR</b>		ITEM	REV
		AXO9001502	C
BOAT MODEL	MODEL YEAR	DRAWING	REV
AX28	2023	DRW01088	B
BY	DATE	DESCRIPTION	SCALE
ANTMIH	23.05.2023	FUEL SYSTEM, EU	1:10
CHECKED	L.C.	TECHNICAL DESCRIPTION	PAGE
ACCEPTED	VILVUO	Manufacturing specification	1 / 3



# BOM

REVISIONS			
REV.	DESCRIPTION	DATE	APPROVED
A	Removed fuel filter and 2x fittings from structure	18.10.2023.	AJu
B	Changed deck filler	7.12.2023.	

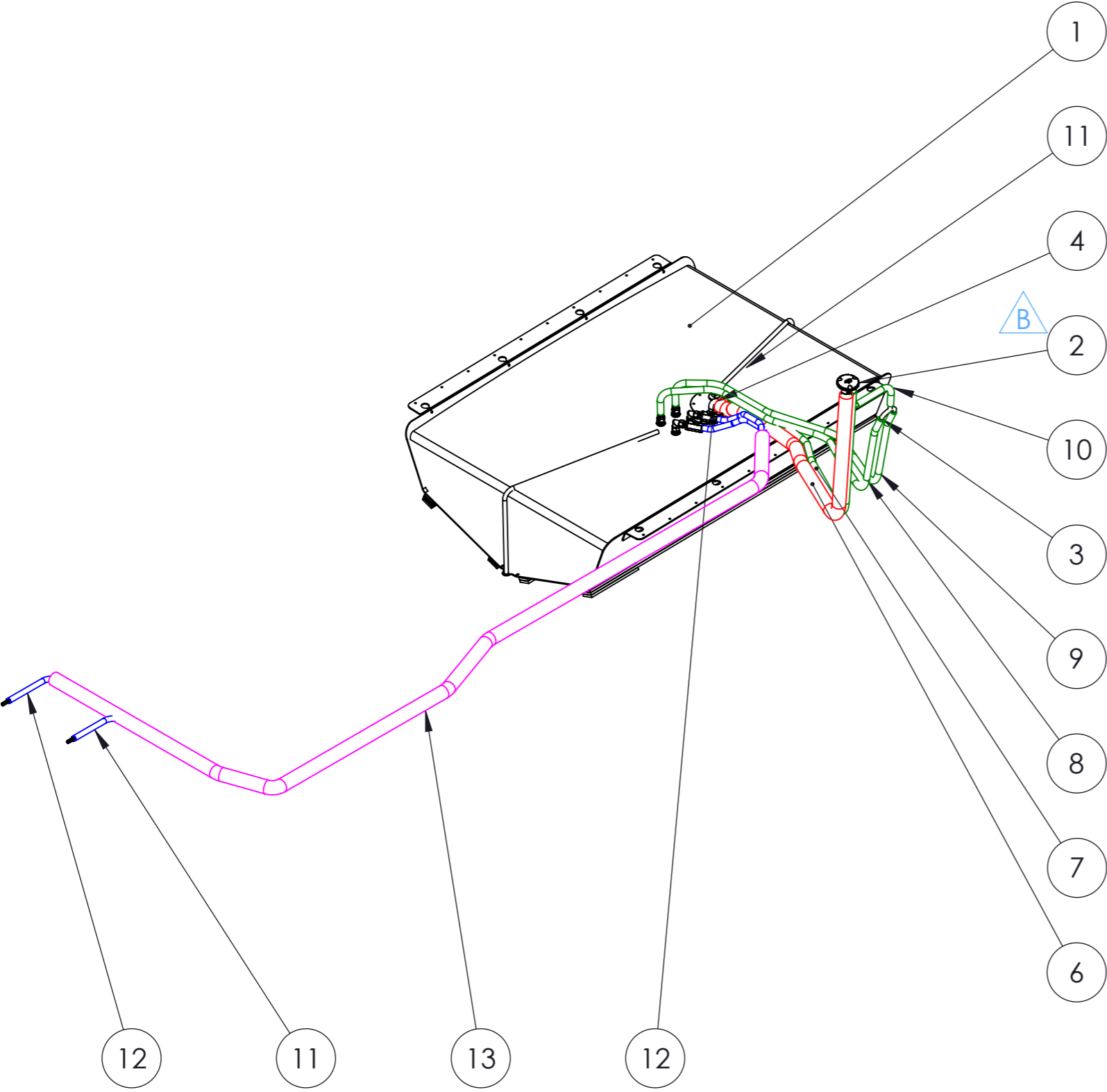

**NOTE:**  
△ A Fuel supply:  
 - 2nd line OPTION for 2x V6 engines  
 +2x  $\phi$  12 hose connector (AXO5000087)

HOSES PLAN				
DESCRIPTION	ITEM	SIZE, m	LENGTH, m	COLOR
Fuel fill	AXO8000040	$\phi$ 38	1,8	—
Fuel supply	AXO8000042	$\phi$ 12	9,3	—
Vent	AXO8000041	$\phi$ 16	5,6	—
Protective	AXO0000270	$\phi$ 46	4,3	—

PART NO.	ITEM	DESCRIPTION	MATERIAL	SIZE, CAPACITY	LENGTH (m)	QTY.
1	AXO8000383, A	FUEL TANK	ALUMINIUM		-	1
2	AXO8000031, A	DECK FILLER	PLASTIC /CHROME	$\phi$ 38, $\phi$ 16	199.78	1
3	AXO8000086, A	T-CONNECTOR	ALUMINIUM	$\phi$ 16	-	1
4	AXO8000090, A	T-CONNECTOR	PLASTIC, POM	$\phi$ 16	-	1
5	AXO8000081, A	CHECK VALVE		$\phi$ 38MM, (1-1/2")	-	1
6	AXO8000040, A	FUEL HOSE	NBR RUBBER	$\phi$ 38	1,8	1
7	AXO8000041, A	FUEL HOSE	NBR RUBBER	$\phi$ 16	1,8	1
8	AXO8000041, A	FUEL HOSE	NBR RUBBER	$\phi$ 16	1,72	1
9	AXO8000041, A	FUEL HOSE	NBR RUBBER	$\phi$ 16	1,72	1
10	AXO8000041, A	FUEL HOSE	NBR RUBBER	$\phi$ 16	0,3	1
11	AXO8000042, A	FUEL HOSE	NBR RUBBER	$\phi$ 12	4,5	1
12	AXO8000042, A	FUEL HOSE	NBR RUBBER	$\phi$ 12	4,8	1
13	AXO0000456, A	PROTECTIVE HOSE	PLASTIC	$\phi$ 54 / $\phi$ 47	4,3	1
14	AXO5000087, A	FITTING	BRASS	$\phi$ 12MM (3/8-18 X 1/2")		2

This document and the information contained in it is proprietary and confidential information of Axopar Boats Oy. Neither this document nor any of the information contained herein may be reproduced, disclosed to others, or used for any purpose other than for the purpose it has been provided without the prior written permission of Axopar Boats Oy.

<b>AXOPAR</b>		ITEM	AXO9001502	REV	C	
BOAT MODEL	AX28	MODEL YEAR	2023	DRAWING	DRW01088	
BY	ANTMIH	DATE	23.05.2023	DESCRIPTION	FUEL SYSTEM, EU	
CHECKED	L.C.	DATE	23.05.2023	TECHNICAL DESCRIPTION	Manufacturing specification	
ACCEPTED	VILVUO	DATE	12.09.2023	SCALE	1:20	
					PAGE	2 / 3



# Positions

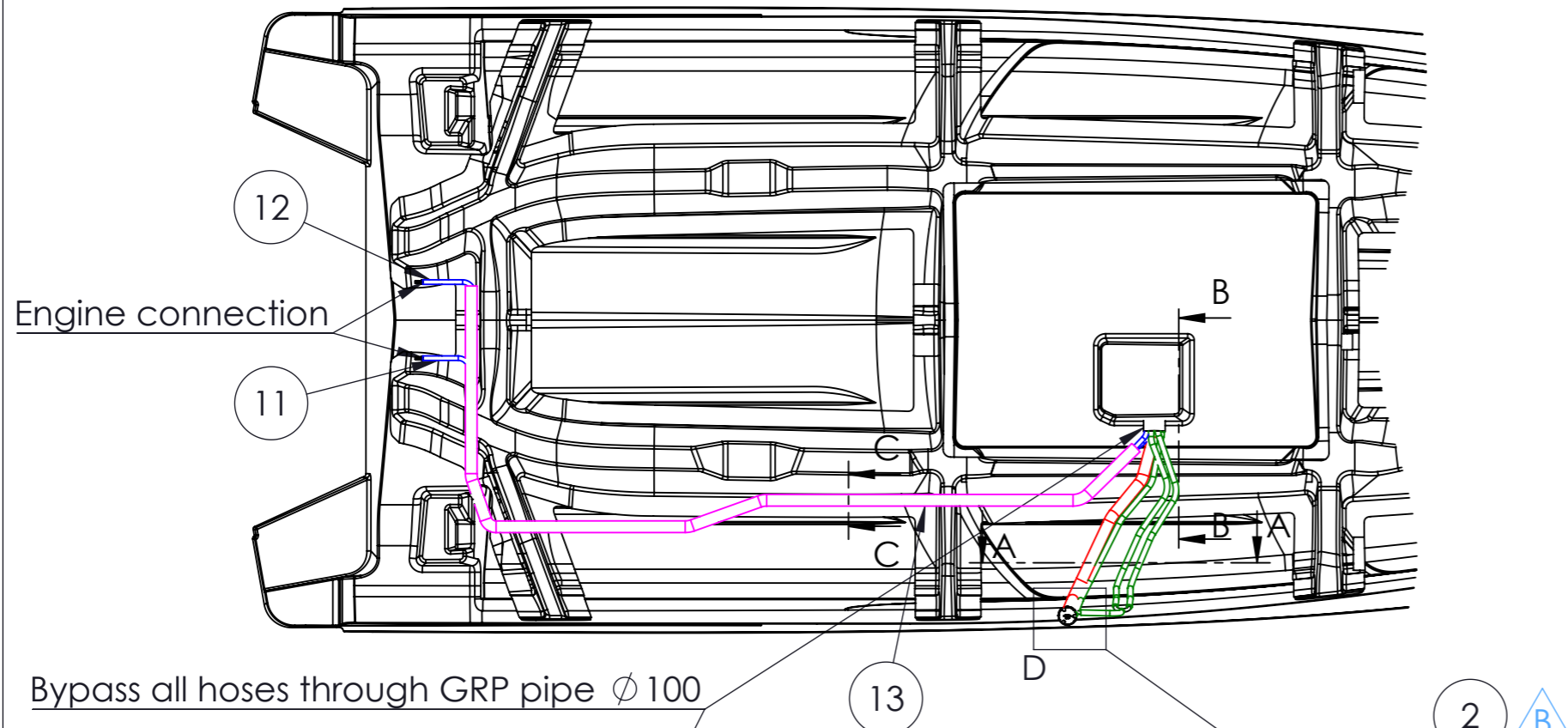

REVISIONS			
REV.	DESCRIPTION	DATE	APPROVED
A	Removed fuel filter and 2x fittings from structure	18.10.2023.	AJu
B	Changed deck filler	7.12.2023.	

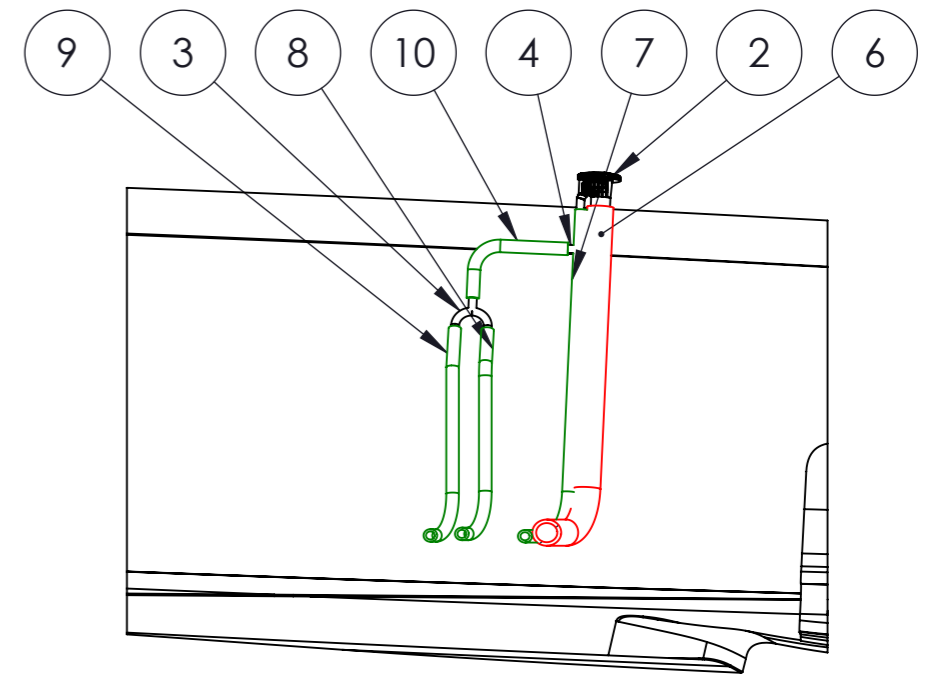

SECTION A-A  
SCALE 1 : 15

**NOTE:**  
 Fuel supply:  
 - 2nd line OPTION for 2x V6 engines  
 + 2x Ø 12 hose connector (AXO5000087)



HOSES PLAN				
DESCRIPTION	ITEM	SIZE, m	LENGTH, m	COLOR
Fuel fill	AXO8000040	Ø 38	1,8	Red
Fuel supply	AXO8000042	Ø 12	9,3	Blue
Vent	AXO8000041	Ø 16	5,6	Green
Protective	AXO0000270	Ø 46	4,3	Pink

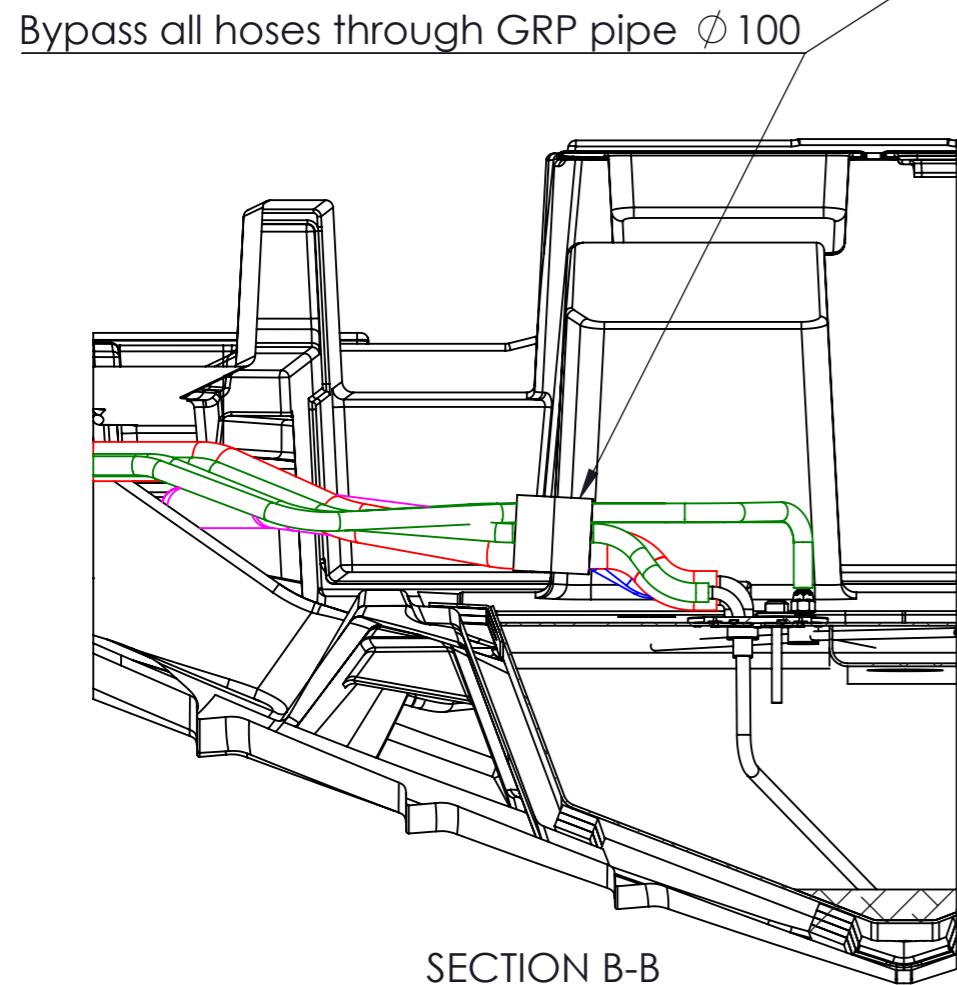

SECTION B-B  
SCALE 1 : 10

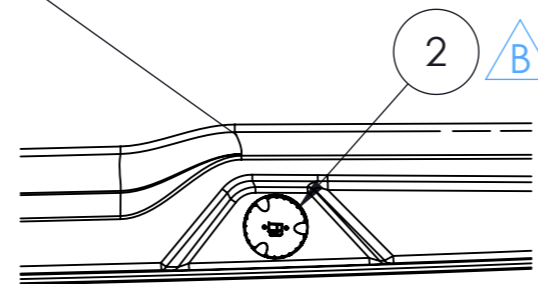

Detail D  
Position on Deck  
SCALE 1:10

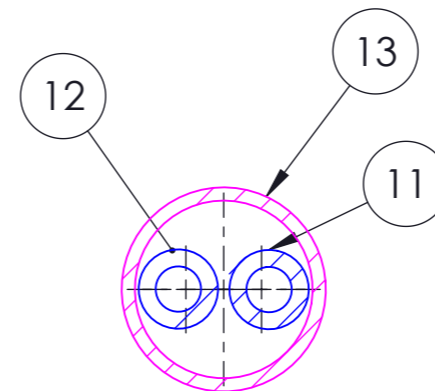

Fuel line in protective hose  
SECTION C-C  
SCALE 1 : 2

This document and the information contained in it is proprietary and confidential information of Axopar Boats Oy. Neither this document nor any of the information contained herein may be reproduced, disclosed to others, or used for any purpose other than for the purpose it has been provided without the prior written permission of Axopar Boats Oy.

<b>AXOPAR</b>		ITEM	AXO9001502	REV	C
BOAT MODEL	AX28	MODEL YEAR	2023	DRAWING	REV
				DRW01088	B
BY	DATE	DESCRIPTION	SCALE	PAGE	
CREATED	ANTMIH	23.05.2023	FUEL SYSTEM, EU	1:30	3 / 3
CHECKED	L.C.	23.05.2023	TECHNICAL DESCRIPTION		
ACCEPTED	VILVUO	12.09.2023	Manufacturing specification		



## 10.2 Fuel system: USA (EPA)



# Neoprene strips on tank

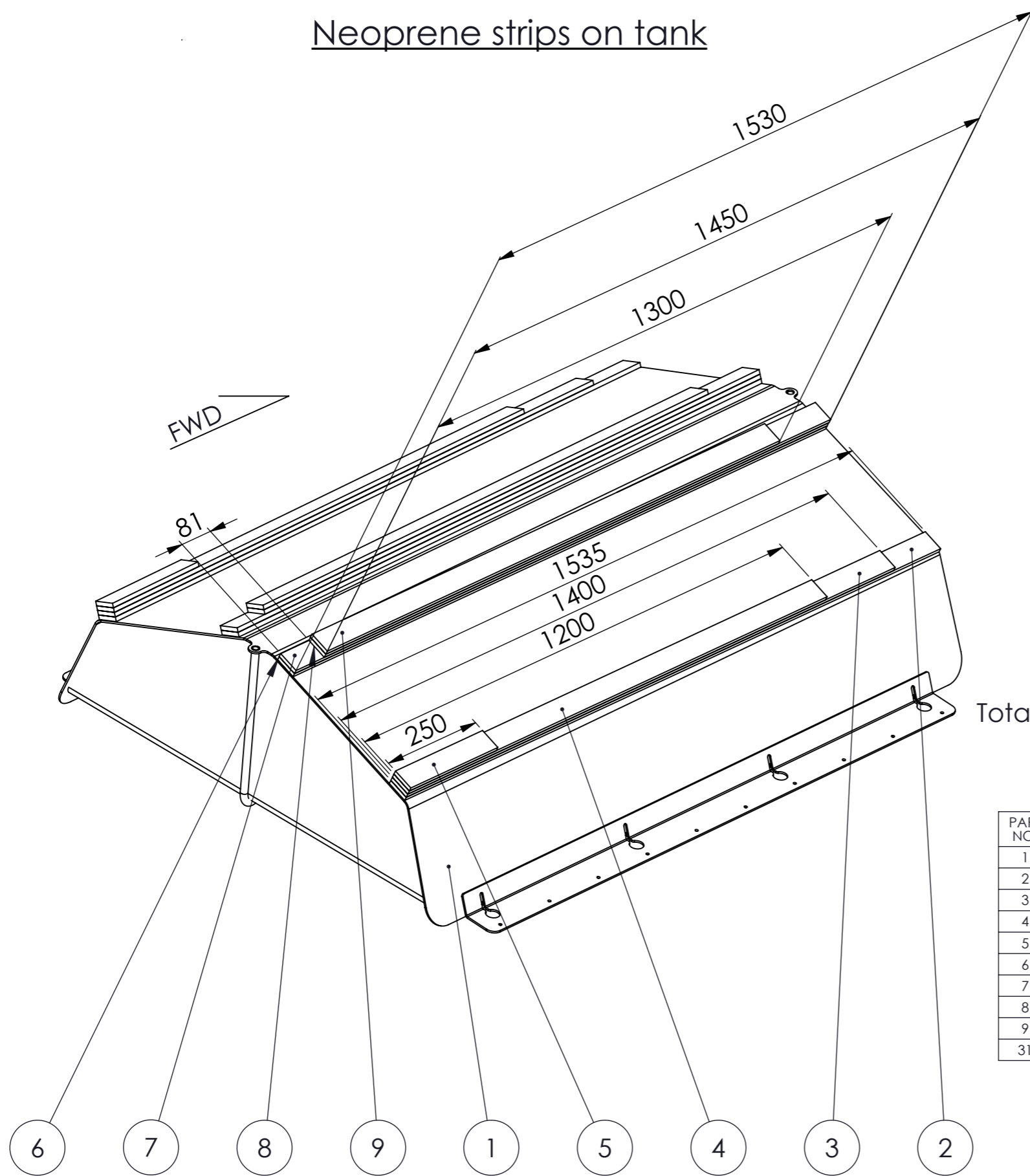

REVISIONS			
REV.	DESCRIPTION	DATE	APPROVED
A	Removed fuel filter and 2x fittings from structure	19.10.2023.	AJu
B	Changed fuel supply hoses	7.12.2023.	

Total length of AXO3000305 Neoprene strips: 20,39m ~ 21m

PART NO.	ITEM	DESCRIPTION	MATERIAL	SIZE, CAPACITY	LENGTH (mm)	QTY.
1	AXO8000383, A	FUEL TANK	ALUMINIUM		-	1
2	AXO3000305, A	GASKET	PLASTIC, PE	50 X 10, 60KG / M3	1535	2
3	AXO3000305, A	GASKET	PLASTIC, PE	50 X 10, 60KG / M3	1400	1
4	AXO3000305, A	GASKET	PLASTIC, PE	50 X 10, 60KG / M3	1200	1
5	AXO3000305, A	GASKET	PLASTIC, PE	50 X 10, 60KG / M3	250	1
6	AXO3000305, A	GASKET	PLASTIC, PE	50 X 10, 60KG / M3	1530	1
7	AXO3000305, A	GASKET	PLASTIC, PE	50 X 10, 60KG / M3	1530	1
8	AXO3000305, A	GASKET	PLASTIC, PE	50 X 10, 60KG / M3	1450	1
9	AXO3000305, A	GASKET	PLASTIC, PE	50 X 10, 60KG / M3	1300	1
31	AXO5000089, A	FUEL FILTER KIT			0,27	1

This document and the information contained in it is proprietary and confidential information of Axopar Boats Oy. Neither this document nor any of the information contained herein may be reproduced, disclosed to others, or used for any purpose other than for the purpose it has been provided without the prior written permission of Axopar Boats Oy.

<b>AXOPAR</b>		ITEM	AXO9001503	REV	C
BOAT MODEL	AX28	MODEL YEAR	2023	DRAWING	DRW01195
BY	ANTMIH	DATE	01.06.2023	DESCRIPTION	FUEL SYSTEM, EPA
CHECKED	L.C.	DATE	01.06.2023	TECHNICAL DESCRIPTION	
ACCEPTED	VILVUO	DATE	12.09.2023	Manufacturing specification	
SCALE	1:10	PAGE	1/3		



# BOM

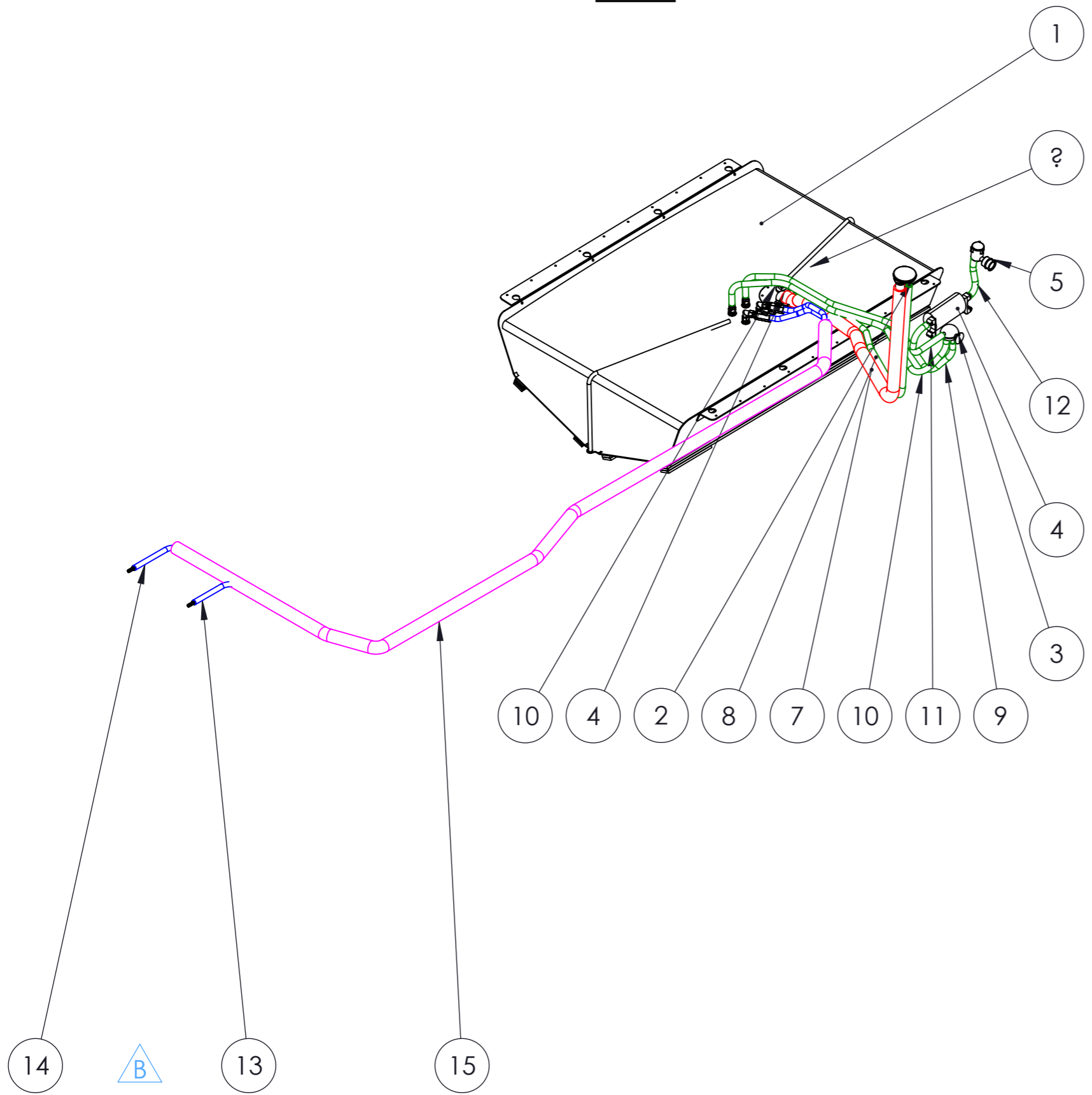

REVISIONS			
REV.	DESCRIPTION	DATE	APPROVED
A	Removed fuel filter and 2x fittings from structure	19.10.2023.	AJu
B	Changed fuel supply hoses	7.12.2023.	

**NOTE:**  
 Fuel supply:  
 - 2nd line **OPTION** for 2x V6 engines  
 + 2x  $\varnothing$  12 hose connector (AXO5000087)

HOSES PLAN				
DESCRIPTION	ITEM	SIZE, m	LENGTH, m	COLOR
Fuel fill	AXO8000040	$\varnothing$ 38	1,8	—
Fuel supply	AXO8000418	$\varnothing$ 12	9,3	—
Vent	AXO8000041	$\varnothing$ 16	5,5	—
Protective	AXO0000270	$\varnothing$ 46	4,3	—

PART NO.	ITEM	DESCRIPTION	MATERIAL	SIZE, CAPACITY	LENGTH (m)	QTY.
1	AXO8000383, A	FUEL TANK	ALUMINIUM		-	1
2	AXO8000324, A	DECK FILLER	BRONZE, CHROMED CAP, PLASTIC BODY	$\varnothing$ 38MM / $\varnothing$ 16MM	-	1
3	AXO8000170, A	AIR/FUEL SEPARATOR	PLASTIC, POLYMER	$\varnothing$ 16MM, (5/8")	-	1
4	AXO8000083, A	CARBON CANISTER		$\varnothing$ 16MM/ $\varnothing$ 16MM (5/8" - 5/8")	-	1
5	AXO8000082, A	TANK VENTILATOR		$\varnothing$ 16MM, (5/8")	-	1
6	AXO8000081, A	CHECK VALVE		$\varnothing$ 38MM, (1-1/2")	-	1
7	AXO8000040, A	FUEL HOSE	NBR RUBBER	$\varnothing$ 38	1,8	1
8	AXO8000041, A	FUEL HOSE	NBR RUBBER	$\varnothing$ 16	1,8	1
9	AXO8000041, A	FUEL HOSE	NBR RUBBER	$\varnothing$ 16	1,5	1
10	AXO8000041, A	FUEL HOSE	NBR RUBBER	$\varnothing$ 16	1,5	1
11	AXO8000041, A	FUEL HOSE	NBR RUBBER	$\varnothing$ 16	0,4	1
12	AXO8000041, A	FUEL HOSE	NBR RUBBER	$\varnothing$ 16	0,3	1
13	AXO8000418, A	FUEL HOSE		$\varnothing$ 12.7	4,5	1
14	AXO8000418, A	FUEL HOSE		$\varnothing$ 12.7	4,8	1
15	AXO0000456, A	PROTECTIVE HOSE	PLASTIC	$\varnothing$ 54 / $\varnothing$ 47	4,3	1
16	AXO5000087, A	FITTING	BRASS	$\varnothing$ 12MM (3/8-18 X 1/2")		2

This document and the information contained in it is proprietary and confidential information of Axopar Boats Oy. Neither this document nor any of the information contained herein may be reproduced, disclosed to others, or used for any purpose other than for the purpose it has been provided without the prior written permission of Axopar Boats Oy.

<b>AXOPAR</b>		ITEM	AXO9001503	REV	C
BOAT MODEL	AX28	MODEL YEAR	2023	DRAWING	DRW01195
BY	ANTMIH	DATE	01.06.2023	DESCRIPTION	FUEL SYSTEM, EPA
CHECKED	L.C.	DATE	01.06.2023	TECHNICAL DESCRIPTION	
ACCEPTED	VILVUO	DATE	12.09.2023	Manufacturing specification	
				SCALE	PAGE
				1:20	2 / 3



# Positions

REVISIONS			
REV.	DESCRIPTION	DATE	APPROVED
A	Removed fuel filter and 2x fittings from structure	19.10.2023.	AJU
B	Changed fuel supply hoses	7.12.2023.	

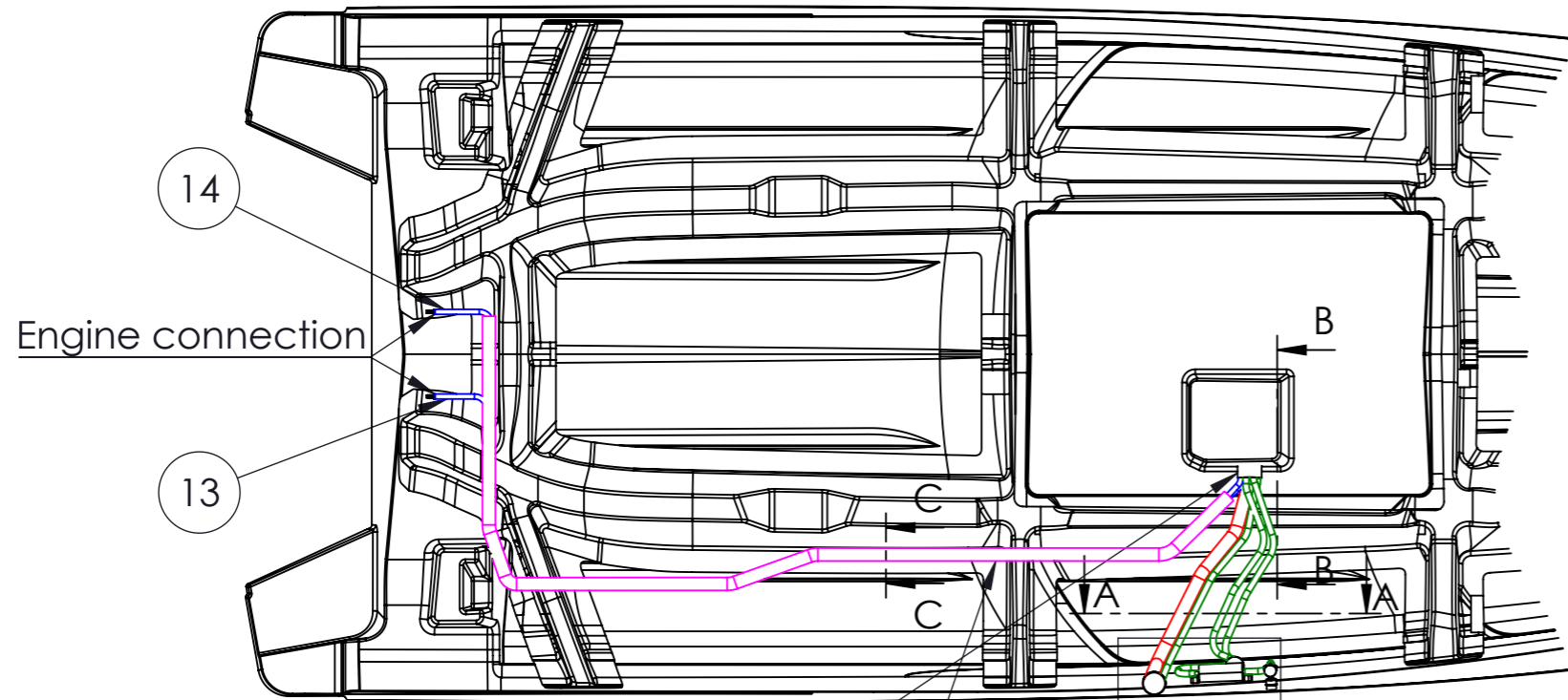

Bypass all hoses through GRP pipe  $\phi$  100

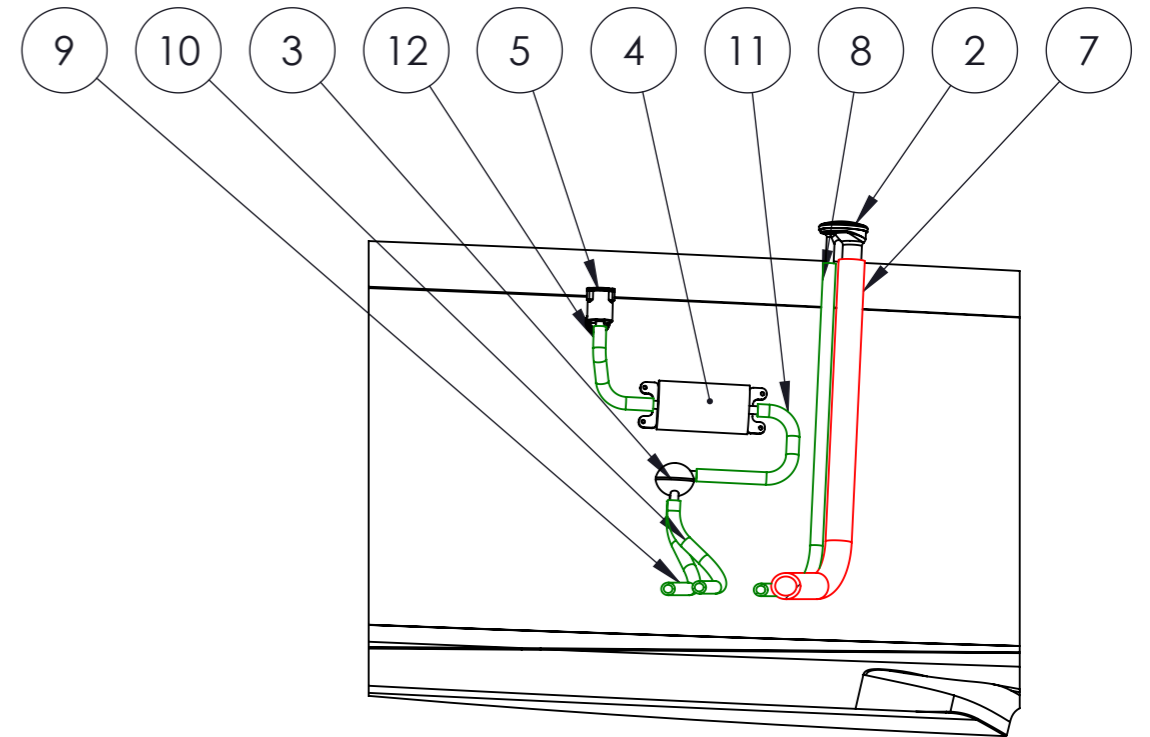

SECTION A-A  
SCALE 1 : 15

**NOTE:**  
Fuel supply:  
- 2nd line OPTION for 2x V6 engines  
+ 2x  $\phi$  12 hose connector (AXO5000087)

HOSES PLAN				
DESCRIPTION	ITEM	SIZE, m	LENGTH, m	COLOR
Fuel fill	AXO8000040	$\phi$ 38	1,8	Red
Fuel supply	AXO8000418	$\phi$ 12	9,3	Blue
Vent	AXO8000041	$\phi$ 16	5,5	Green
Protective	AXO0000270	$\phi$ 46	4,3	Pink

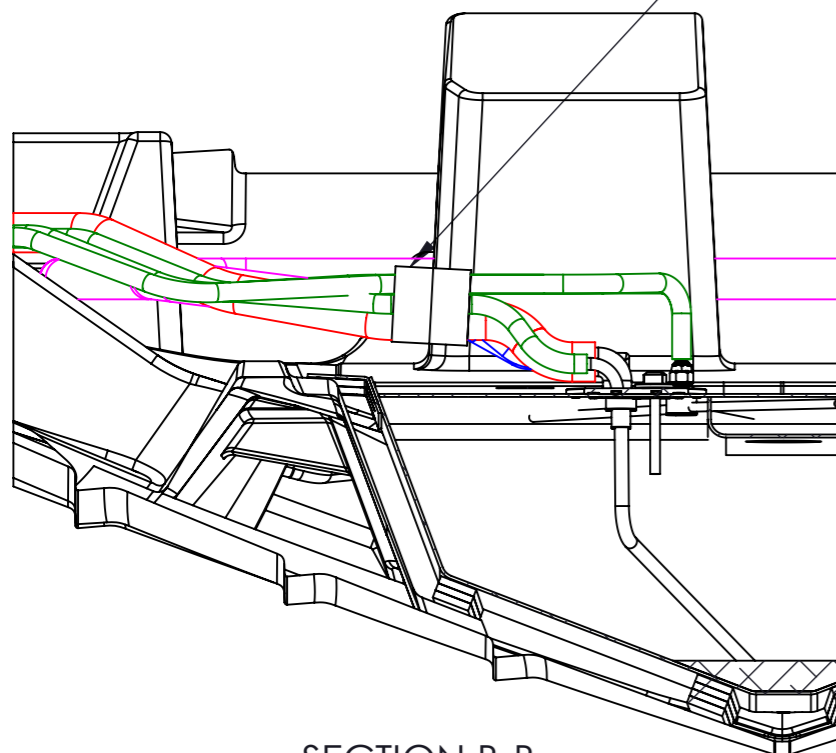

SECTION B-B  
SCALE 1 : 10

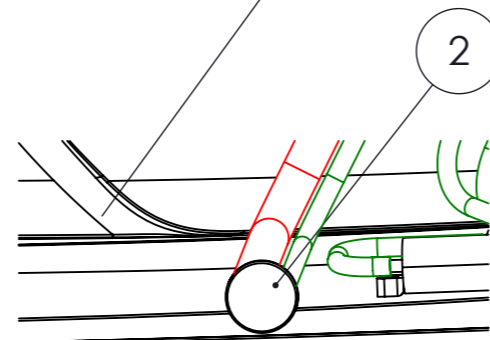

Detail D  
Position on Deck  
SCALE 1:10

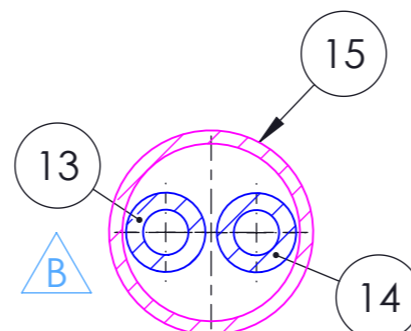

Fuel line in protective hose  
SECTION C-C  
SCALE 1 : 2

This document and the information contained in it is proprietary and confidential information of Axopar Boats Oy. Neither this document nor any of the information contained herein may be reproduced, disclosed to others, or used for any purpose other than for the purpose it has been provided without the prior written permission of Axopar Boats Oy.

<b>AXOPAR</b>		ITEM	AXO9001503	REV	C
BOAT MODEL	AX28	MODEL YEAR	2023	DRAWING	REV
				DRW01195	B
BY	DATE	DESCRIPTION	SCALE	PAGE	
CREATED	ANTMIH	01.06.2023	FUEL SYSTEM, EPA	1:30	3 / 3
CHECKED	L.C.	01.06.2023	TECHNICAL DESCRIPTION		
ACCEPTED	VILVUO	12.09.2023	Manufacturing specification		



# 11 Appendix III: Electrical diagrams

# Axopar 28 Mk3 230Vac SYSTEM LAYOUT

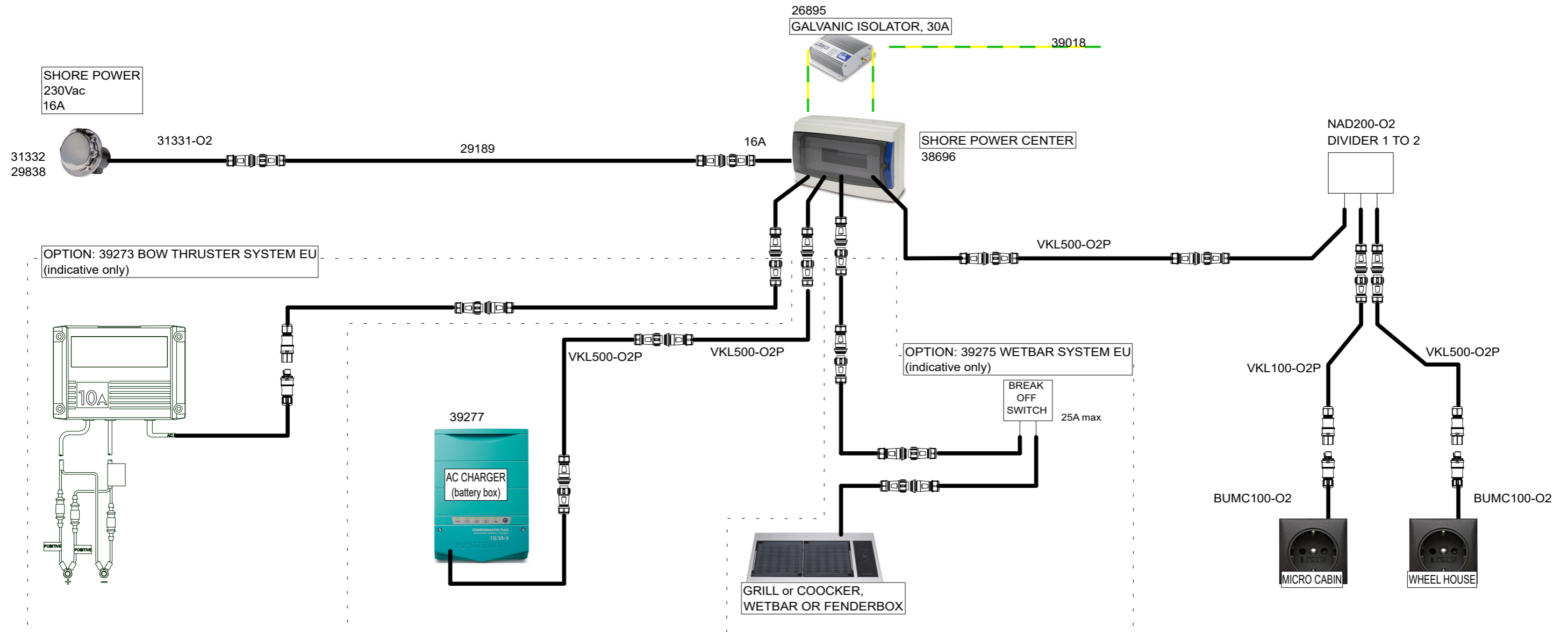

### BASIC COMPONENTS

- 31332 - Shore Power Cable 16A/250V 25m - Ratio Electric 2822
- 29838 - SHORE POWER MLC ADAPTER 200mm - 2,5mm2 -
- 31331-O2 - Deck Contact 16A/250V S.S. IP56 - Ratio Electric MP16-10
- 29189 - CONNECTION CABLE 200CM IP68 2,5mm2 WITH TUBE -
- 26895 - Galvanic Isolator 30A, 120/240 VAC - ProSafe FS30
- 39018 - AC GROUNDING CABLE EURO - 1000CM 6mm2 WITH TUBE
- 38696 - Axopar 28 SHORE POWER CENTER EU -
- 4pcs VKL500-O2P - CONNECTION CABLE 500CM IP68 1,5 mm2 WITH TUBE -
- 39277 ChargeMaster Plus 12/35-3 with O2
- NAD200-O2 - DIVIDER -
- VKL100-O2P - CONNECTION CABLE 100CM IP68 1,5 mm2 WITH TUBE -
- 2pcs BUMC100-O2 - WALL SOCKET, single pos. flush mounting - Berker, matt chrome

Date 5.5.2023

Drawing by PF

Sheet rev. 1

Project rev. A



Copyright by

Axopar

Boat

28 MK3

Boat model

Sub-product code

SHORE POWER SYSTEM EU

Title

38694

Product code

HL

Loc

Project ID

1 / 3

Sheet

# Axopar 28 Mk3 120Vac SYSTEM LAYOUT

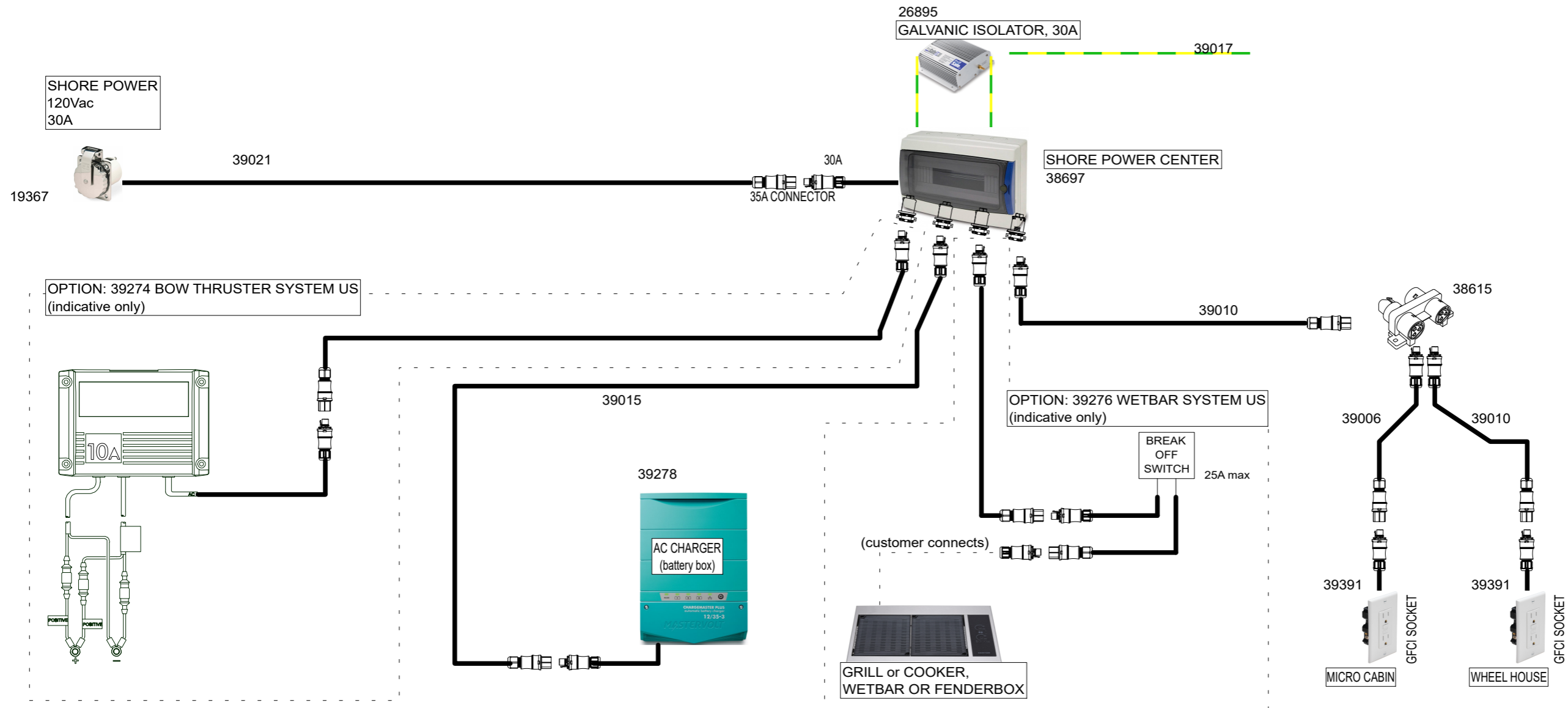

- STANDARD COMPONENTS - parts list**
- 19367 - Shore Power Cable 30A/125V 15m Yellow - Marinc 199119
  - 39021 - DECK CONTACT MARINCO US PHOENIX - 250cm AWG 10 WITH TUBE
  - 26895 - Galvanic Isolator 30A, 120/240 VAC - ProSafe FS30
  - 39017 - AC GROUNDING CABLE US - 1000cm AWG 10 WITH TUBE
  - 38697 - Axopar 28 SHORE POWER CENTER US -
  - 39015 - 10m RST CONNECTION CABLE, AWG14 - USA -
  - 39278 ChargeMaster Plus 12/35-3 with RST
  - 2pcs 39010 - 5m RST CONNECTION CABLE, AWG14 - USA -
  - 38615 - Distribution block 11 / 30, parallel connection - Wieland 96.030.0153.1
  - 39006 - 1m RST CONNECTION CABLE, AWG14 - USA -
  - 2pcs 39391 GFCI RECEP. NEMA 5-15R, White, RST20 - USA A

Date 5.5.2023  
 Drawing by PF  
 Sheet rev. 1  
 Project rev. A



Boat	Sub-product code	38695	Product code	Project ID
Boat model	SHORE POWER SYSTEM US		HL	1 / 3 Sheet
	Title	Loc		

Date of modification	Modified by	Description
1		
2		
3		
4		

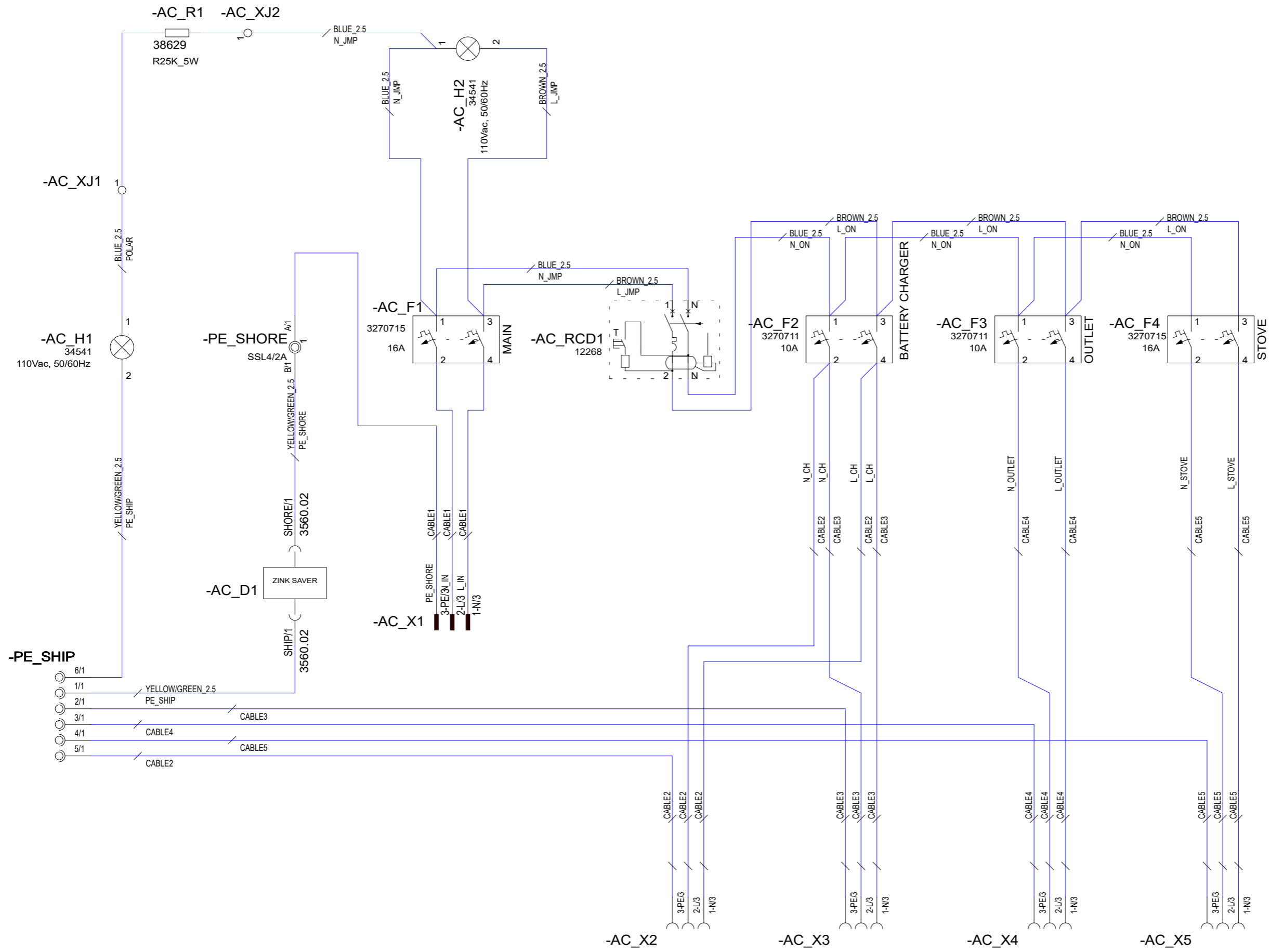

Date 11.4.2023  
 Drawing by  
 Sheet rev. 1  
 Project rev. A



Axopar  
 Boat 28  
 Boat model

Sub-product code		Product code		Project ID	
SHORE POWER		HL		1 / 4	
CENTER EU		Loc			
Title				Sheet	

ALL CABLES AND WIRING ARE H07V2-K (SINGLE WIRES) OR YZW (22981/22980)

NOTICE: ADD LABELS INSIDE BOX

NOTICE! ADD LABELS TO CABLES  
FOR EXAMPLE  
SERVICE BT: +

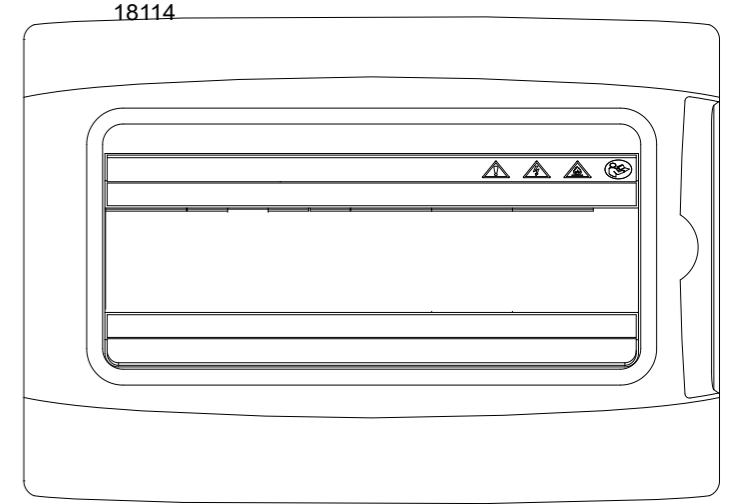
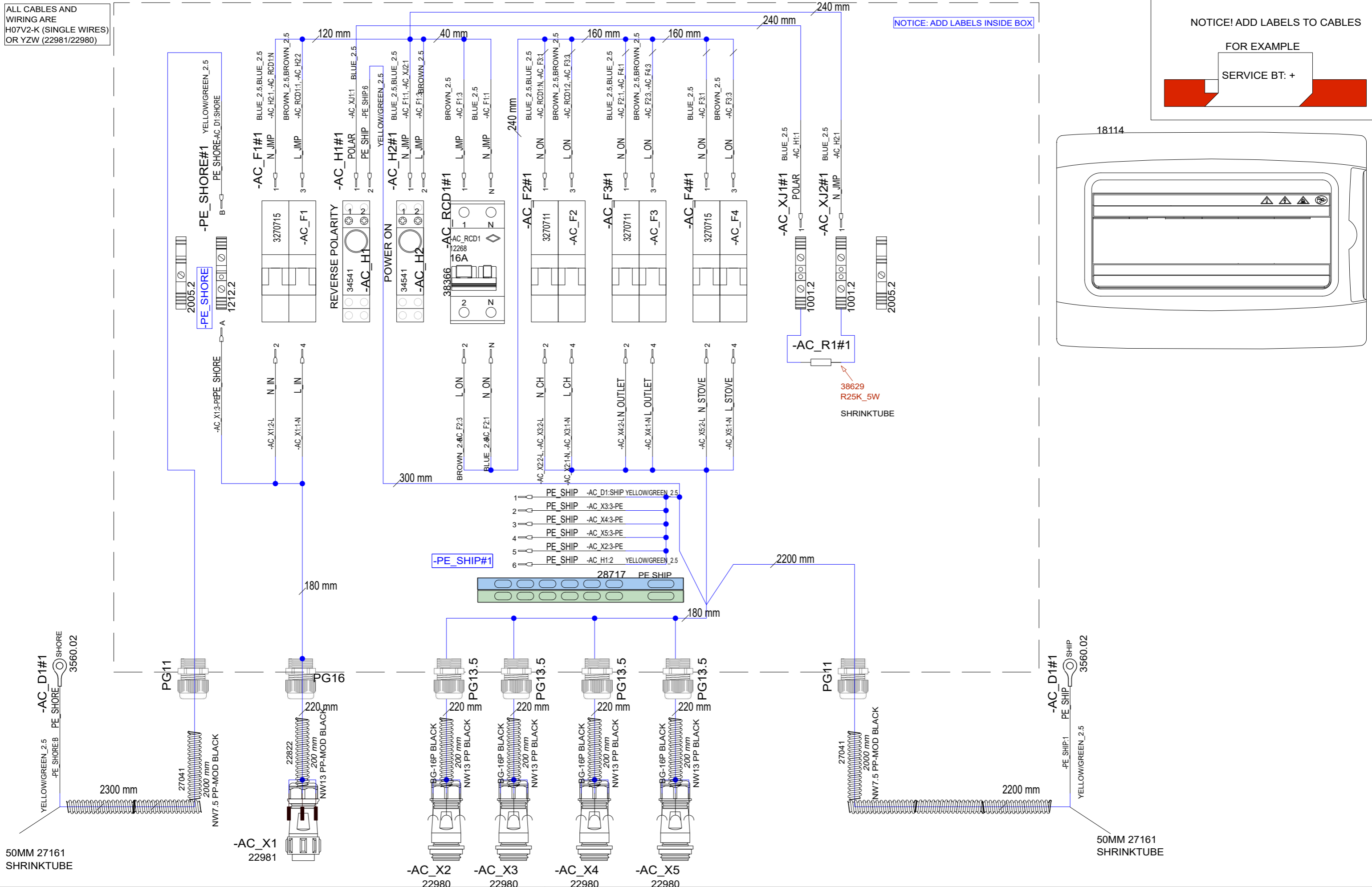

Date of modification			Date 11.4.2023			Axopar			38696		
Modified by			Drawing by			Boat 28			Sub-product code		
Description			Sheet rev. 1			Boat model			Product code		
			Project rev. A			SHORE POWER CENTER EU			Project ID		
			Copyright by NAVIX			Title			HL		
									Loc		
									2 / 4		
									Sheet		



For drilling use  
29168 - FAMATEL 18114 PG JIG -

PG11 = Ø19 mm

PG13,5 = Ø21 mm

PG16 = Ø23 mm

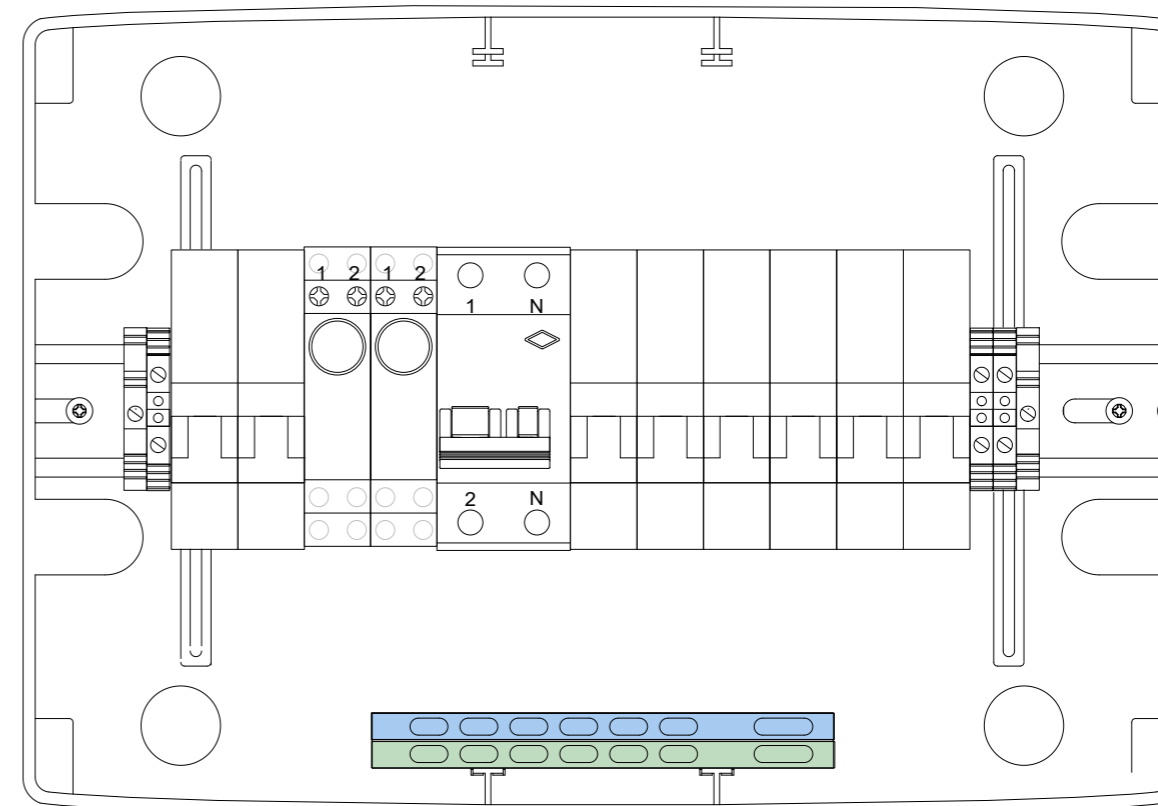

ENCLOSURE:  
18114

ENCLOSURE:  
18114

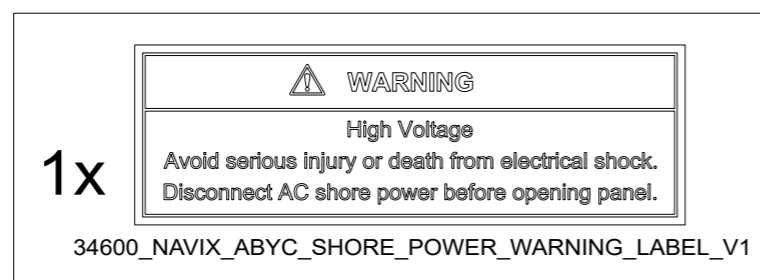

1x

INCLUDE LABEL

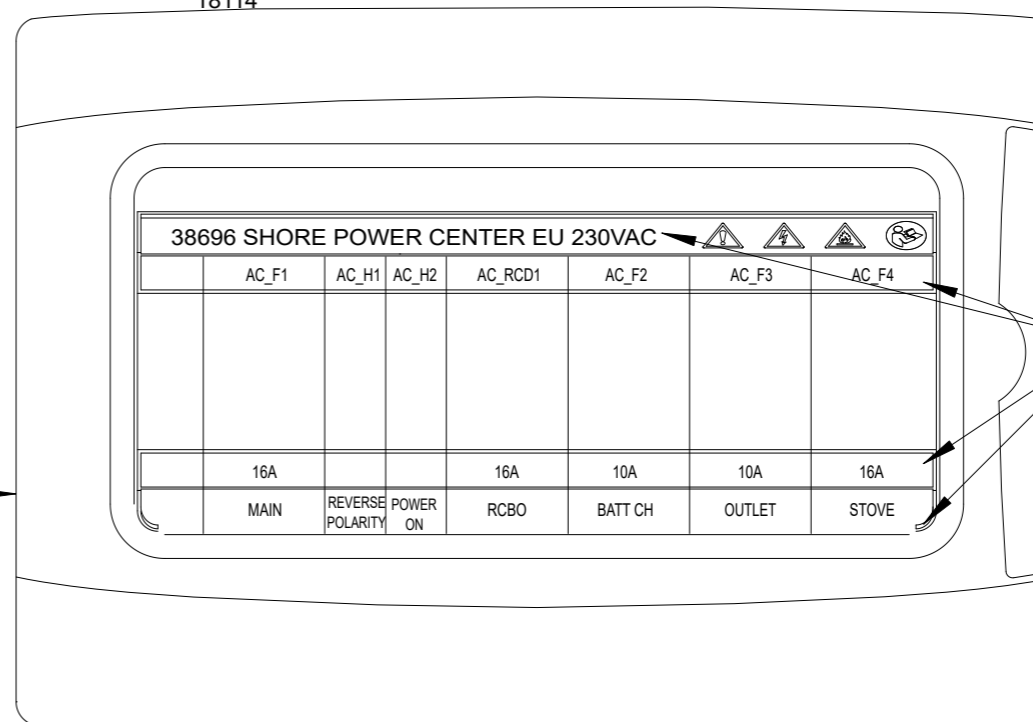

ADD TEXTS WITH DYMO

			Date	11.4.2023	Axopar		38696			
			Drawing by		Boat	28	Sub-product code	Product code	Project ID	
			Sheet rev.	1	Boat model		SHORE POWER CENTER EU		HL	3 / 4
Date of modification	Modified by	Description	Project rev.	A			Title	Loc	Sheet	
1	2	3	4	5	6	7	8			

# SPC TARKASTUSPÖYTÄKIRJA

## SPC INSPECTION SHEET

TUOTE TARRA /  
PRODUCT LABEL

\* PPKKVV-JÄRJESTYSNUMERO / DDMMYY-RUNNING NUMBER (Esim. 11. maaliskuuta 2013 tehty tuote on sarjanumeroltaan 110313-01, seuraava on 110313-02 jne.)

SARJANUMERO* / SERIAL NUMBER*						
JOHDOT KIINNI OIKEIN / CORRECT CONNECTIONS						
MAADOITUS TULEVAT JA LÄHTEVÄT / GROUND CONNECTION IN AND OUT						
VVS JA TOTSIT I-ASENNOSSA / RCBO AND CIRCUIT BREAKERS IN I-POSITION						
ERISTYSVASTUS (mA) max lukema ** / ISOLATION RESISTOR (mA) max **						
MAAPIIRI 10A (Ohm) max lukema ** / GROUND CIRCUIT 10A (Ohm) max **						
TOIMINNALLINEN JA VVS TESTAUS / FUNCTIONAL AND RCBO TEST						
SARJANUMERO TARRA / SERIAL NUMBER STICKER						
PVM / DATE						
TESTASI / TESTED BY						

Tehty CENELEC EN 50106 mukaan / Made according to CENELEC EN 50106

\*\*ERISTYSVASTUS JA MAAPIIRI TESTATTAVA JOKAISEEN SISÄÄNTULOON JA ULOSMENOON / ISOLATION RESISTOR AND GROUND CIRCUIT SHOULD BE TESTED FOR EVERY IN AND OUT

RAJA-ARVOT / LIMITS:

ERISTYSVASTUS / ISOLATING RESISTOR 1000V = <20mA

MAAPIIRI / GROUND CIRCUIT 10A = <0,2 Ohm

				Date	27.4.2023		Axopar		
				Drawing by			Boat	Sub-product code	38696
				Sheet rev.	1		28	Product code	HL
				Project rev.	A		Boat model	Title	SHORE POWER CENTER EU
Date of modification	Modified by	Description						Loc	4 / 4
1				4					Sheet
									8



Copyright by

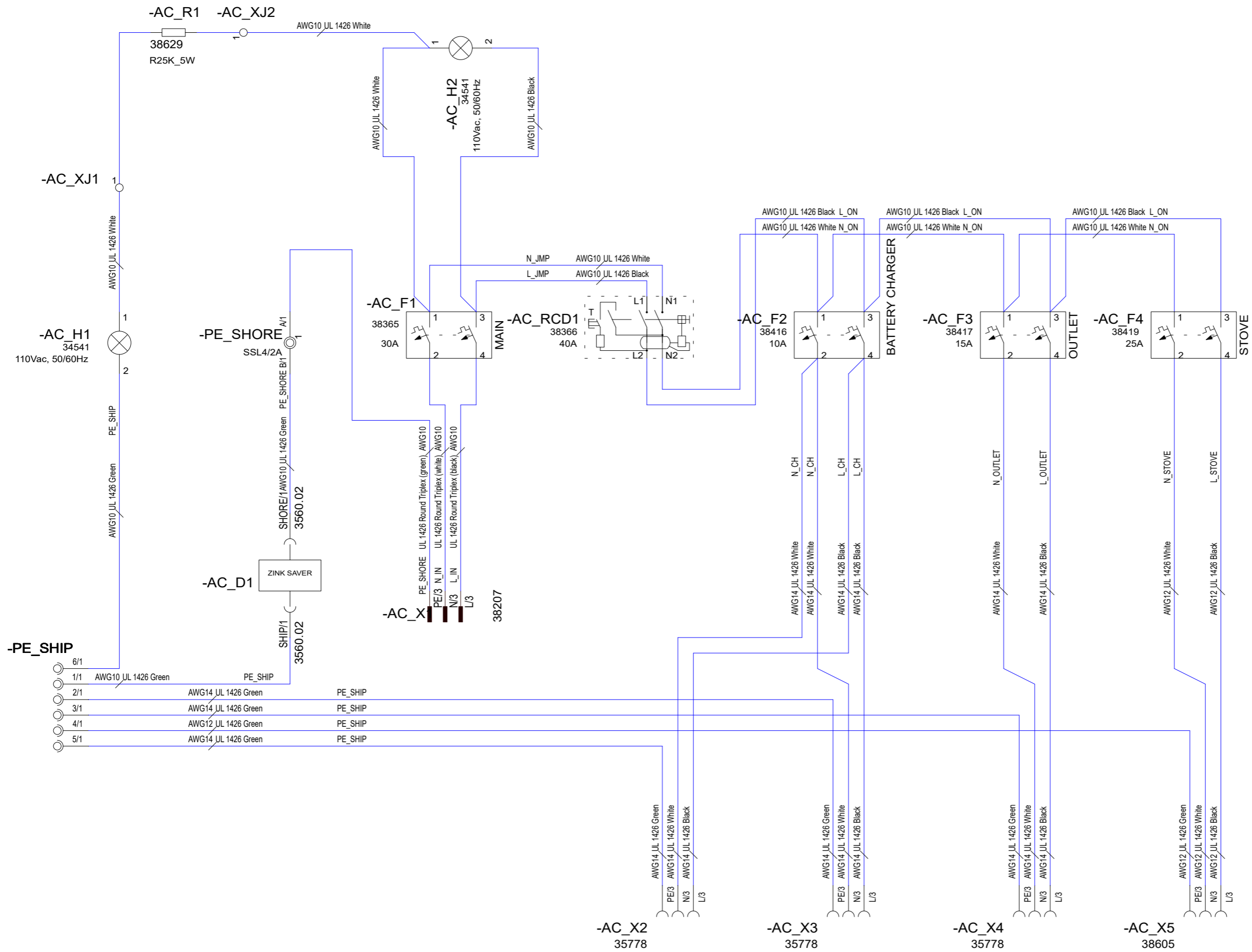

			Date	11.4.2023	Axopar						
			Drawing by			Boat			Sub-product code	Product code	Project ID
			Sheet rev.	1		28	SHORE POWER CENTER US		HL		
			Project rev.	A		Boat model	Title	Loc	1 / 4		Sheet
Date of modification	Modified by	Description			Copyright by						

NOTICE: ADD LABELS INSIDE BOX

NOTICE! ADD LABELS TO CABLES

FOR EXAMPLE

SERVICE BT: +

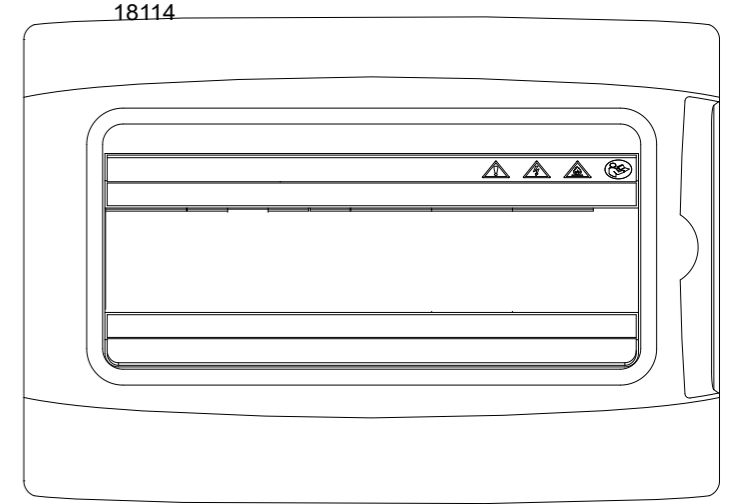
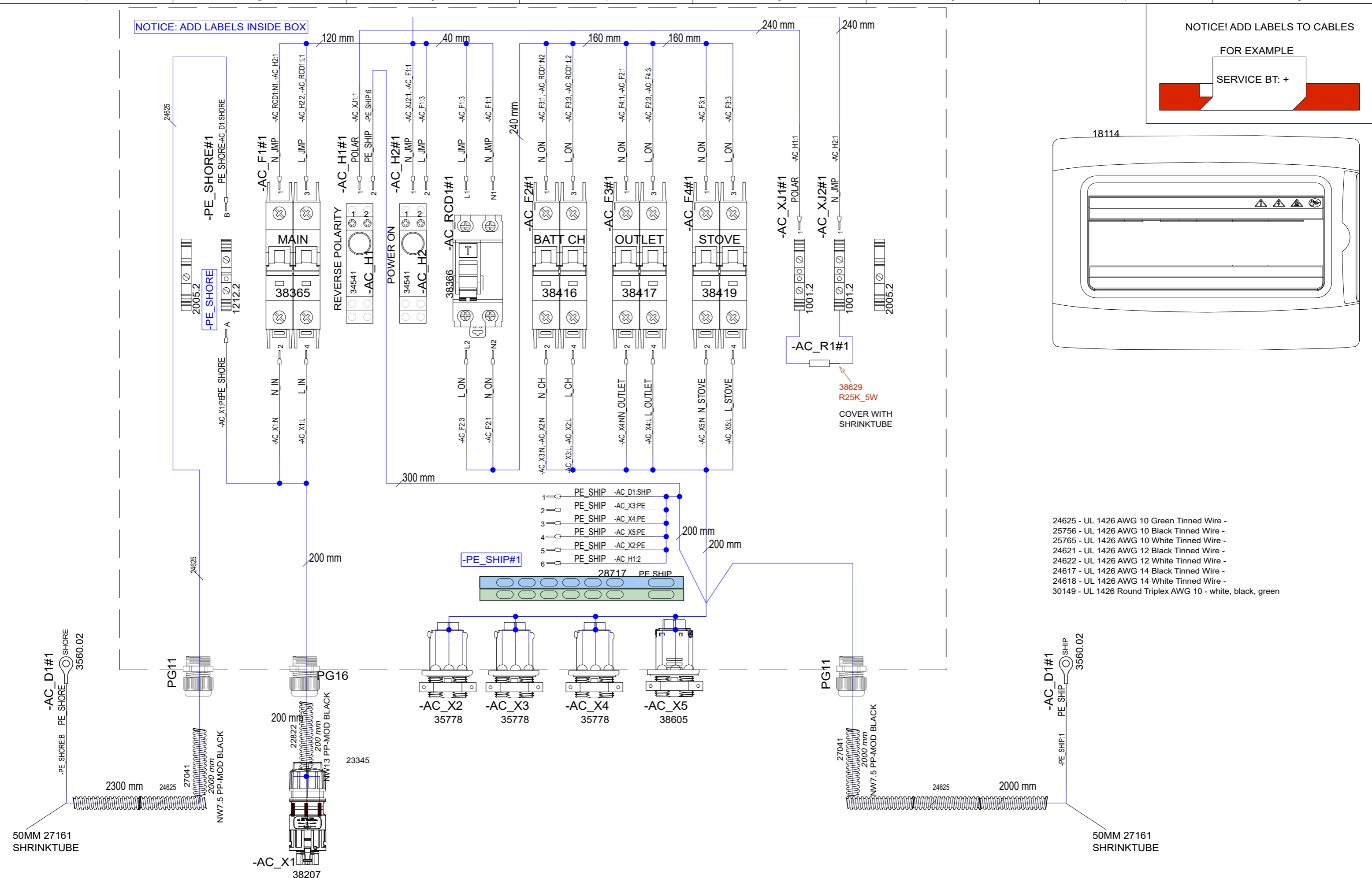

- 24625 - UL 1426 AWG 10 Green Tinned Wire -
- 25756 - UL 1426 AWG 10 Black Tinned Wire -
- 25765 - UL 1426 AWG 10 White Tinned Wire -
- 24621 - UL 1426 AWG 12 Black Tinned Wire -
- 24622 - UL 1426 AWG 12 White Tinned Wire -
- 24617 - UL 1426 AWG 14 Black Tinned Wire -
- 24618 - UL 1426 AWG 14 White Tinned Wire -
- 30149 - UL 1426 Round Triplex AWG 10 - white, black, green

			Date	11.4.2023	Axopar		38697			
			Drawing by		Boat	28	Sub-product code	Product code	Project ID	
			Sheet rev.	1	SHORE POWER CENTER US		HL		2 / 4	
Date of modification	Modified by	Description	Project rev.	A	Boat model		Title	Loc	Sheet	

For drilling use  
 29168 - FAMATEL 18114 PG JIG -  
 PG11 = Ø19 mm  
 PG13,5 = Ø21 mm  
 PG16 = Ø23 mm

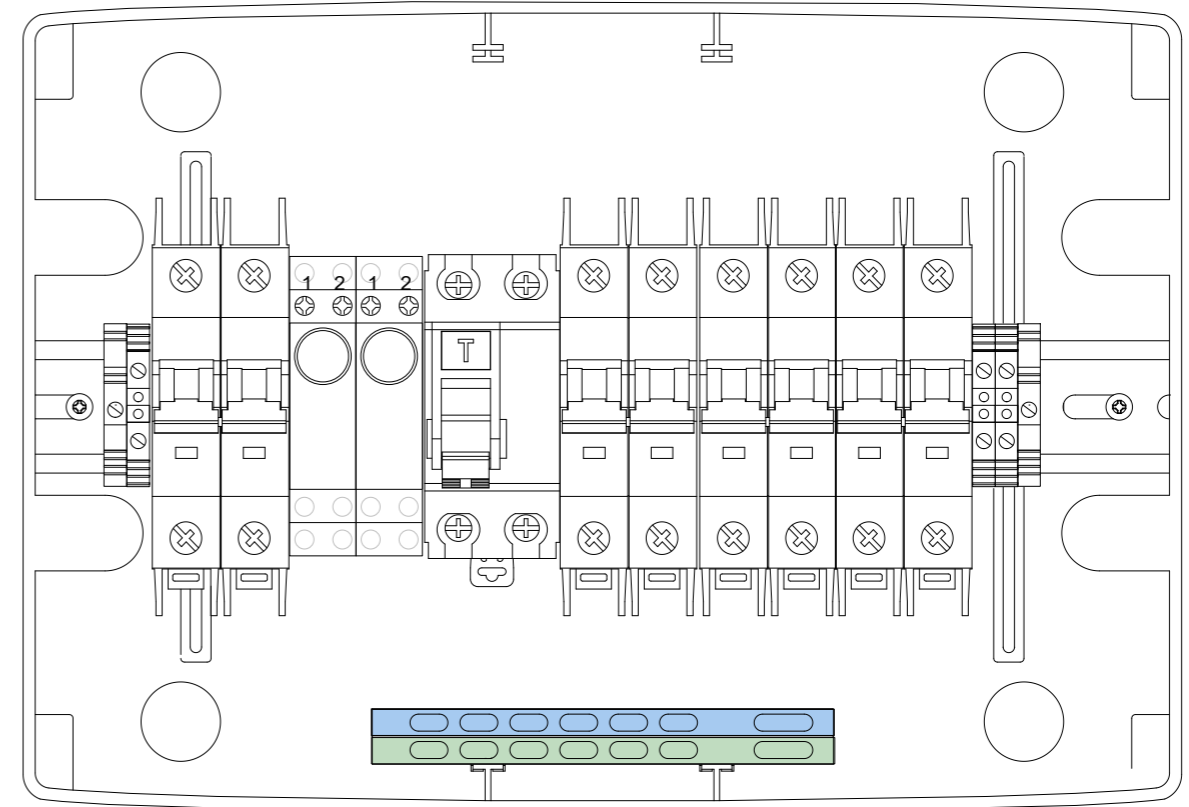

ENCLOSURE:  
18114

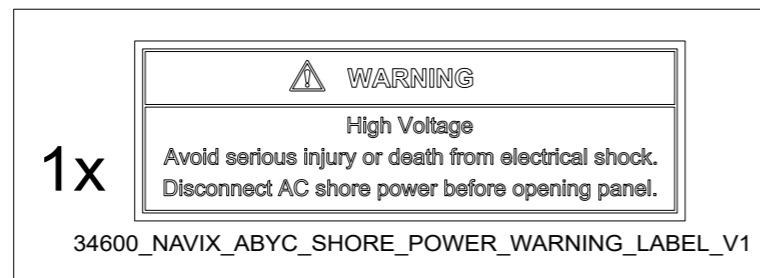

1x

INCLUDE LABEL

ENCLOSURE:  
18114

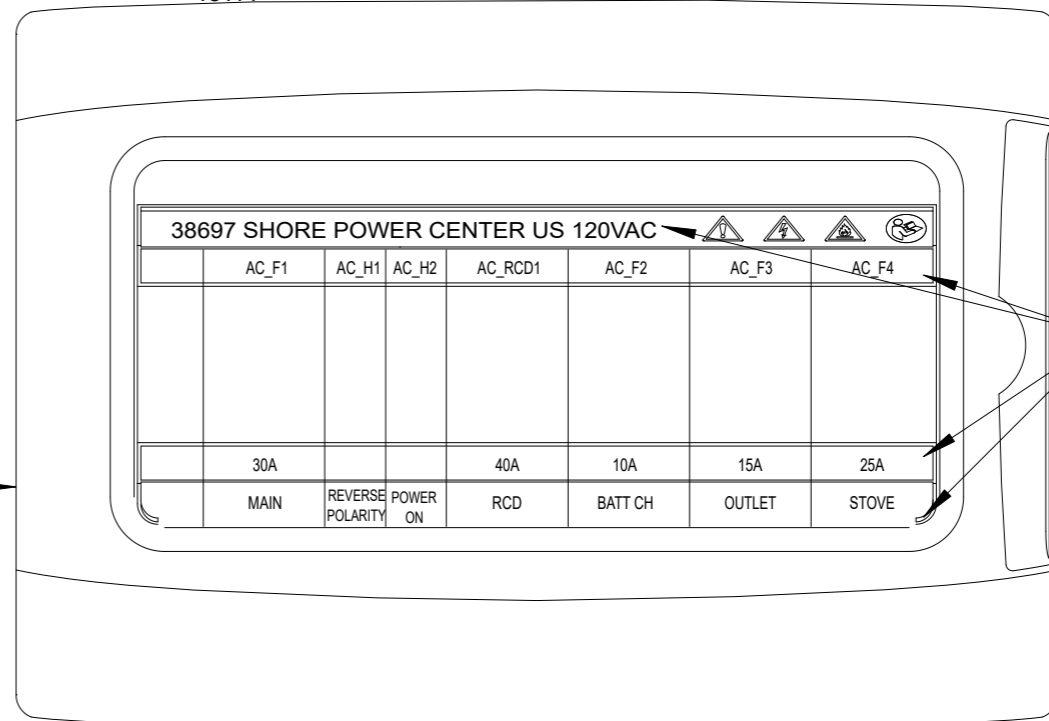

ADD TEXTS WITH DYMO

			Date	11.4.2023	Axopar		38697			
			Drawing by		Boat	28	Sub-product code	Product code	Project ID	
			Sheet rev.	1	Boat model		SHORE POWER CENTER US		HL	3 / 4
Date of modification	Modified by	Description	Project rev.	A			Title	Loc	Sheet	
1	2	3	4	5	6	7	8			

# USA SPC INSPECTION SHEET

PRODUCT LABEL

\* DDMMYY-RUNNING NUMBER (For example. 11th March 2019 made product has serial number 110319-01, next is 110319-02 etc.)

SERIAL NUMBER*						
----------------	--	--	--	--	--	--

VISUAL/ MANUAL

1. PERFORM FULL SYSTEM TEST -LABEL IN PLACE						
2. CORRECT COMPONENTS AND CONNECTIONS						
3. GROUND CONNECTION IN AND OUT						
4. RCBO AND CIRCUIT BREAKERS IN I-POSITION						

TESTER

5. ISOLATION RESISTANCE (mA) max **						
6. GROUND CIRCUIT 10A (Ohm) max **						
7. RCD TEST, (ms @30mA) max						
8. POLARITY TEST, PASS or FAIL **						

115Vac VOLTAGE LIVE

9. FUNCTIONAL AND RCD*** TEST, PASS or FAIL						
---	--	--	--	--	--	--

SERIAL NUMBER STICKER						
-----------------------	--	--	--	--	--	--

DATE						
------	--	--	--	--	--	--

TESTED BY						
-----------	--	--	--	--	--	--

Made according to CENELEC EN 50106:2008 WITH ADDITION OF (8) POLARITY TEST AND (9) 115Vac FUNCTIONAL AND RCD TEST

\*\* (5) ISOLATION RESISTANCE, (6) GROUND CIRCUIT AND (8) POLARITY TEST SHOULD BE TESTED FOR EVERY IN AND OUT

\*\*\* (9) RDC TEST-BUTTON OPERATION VERIFICATION

LIMITS:

ISOLATING RESISTOR 1000V = <5mA

GROUND CIRCUIT 10A = <0,2 Ohm

RDC TEST, Time <100mS @30mA

REVISION B

				Date	27.4.2023		Axopar			
				Drawing by			Boat	Sub-product code		38697
				Sheet rev.	1		28	SHORE POWER		HL
				Project rev.	A		CENTER US		Project ID	
Date of modification	Modified by	Description				Boat model	Title		Loc	4 / 4
1		2	3	4	5	6	7	8	Sheet	



# AFT HULL

## -X.7A#1 DECK HARNESS

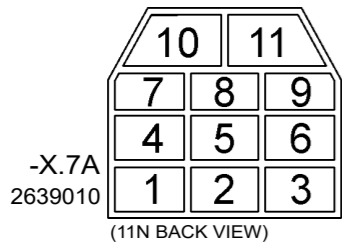

1	STB_TRIM+	-A14A:1	RED_2.5
2	STB_TRIM-	-A14A:2	GREY_2.5
3	PORT_TRIM+	-A14B:1	RED_2.5
4	PORT_TRIM-	-A14B:2	GREY_2.5
5	UW_LIGHT	-H37:+, -H38:+	WHITE/YELLOW_1.5, WHITE/YELLOW_1.5
6	INPUT-	-H37:-, -H38:-	YELLOW_1.5, YELLOW_1.5
7			
8			
9	BPA_AUTO	-M4:Auto.	RED_4
10	BPA_MAN	-M4:Man.	RED_4
11	INPUT-	-M4:-	YELLOW_4

2639010

-A14A  
DT06-2S  
10930002  
10930102  
W2S

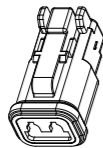

## -A14A#1 TRIM TAB STBD

1	STB_TRIM+	-X.7A:1	RED_2.5
2	STB_TRIM-	-X.7A:2	GREY_2.5

DT06-2S

## TRIM TAB PORT -A14B#1

1	PORT_TRIM+	-X.7A:3	RED_2.5
2	PORT_TRIM-	-X.7A:4	GREY_2.5

DT06-2S

-A14B  
DT06-2S  
10930002  
10930102  
W2S

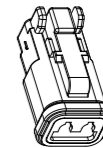

## -H38#1 UW LIGHT

+	UW_LIGHT	-X.7A:5	WHITE/YELLOW_1.5
-	INPUT-	-X.7A:6	YELLOW_1.5

800 mm

## UW LIGHT -H37#1

+	UW_LIGHT	-X.7A:5	WHITE/YELLOW_1.5
-	INPUT-	-X.7A:6	YELLOW_1.5

800 mm

## BILGE PUMP AFT -M4#1

RED_4	-X.7A:10	BPA_MAN	<input type="checkbox"/> Man.
RED_4	-X.7A:9	BPA_AUTO	<input type="checkbox"/> Auto.
YELLOW_4	-X.7A:11	INPUT-	<input type="checkbox"/> -

600 mm

# FDW HULL

## -X.7B#1 DECK HARNESS

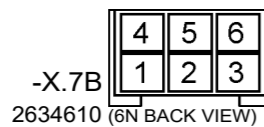

1	FW_PUMP	-M11:+	RED_2.5
2	INPUT-	-M11:-	YELLOW_2.5
3	BPF_AUTO	-M3:Auto.	RED_2.5
4	BPF_MAN	-M3:Man.	RED_2.5
5	INPUT-	-M3:-	YELLOW_2.5
6			

2634610

## FRESH WATER PUMP -M11#1

RED_2.5	-X.7B:1	FW_PUMP	<input type="checkbox"/> +
YELLOW_2.5	-X.7B:2	INPUT-	<input type="checkbox"/> -

1800 mm

## BILGE PUMP FWD -M3#1

RED_2.5	-X.7B:4	BPF_MAN	<input type="checkbox"/> Man.
RED_2.5	-X.7B:3	BPF_AUTO	<input type="checkbox"/> Auto.
YELLOW_2.5	-X.7B:5	INPUT-	<input type="checkbox"/> -

1200 mm

800 mm

Date 6.4.2023

Drawing by PF

Sheet rev. 1

Project rev. A



Copyright by

Axopar

Boat  
28 MK3

Boat model

Sub-product code  
HULL HARNESS

Title

38689  
Product code

HL  
Loc

2004468  
Project ID

25 /  
Sheet

Date of modification Modified by Description

1

2

3

4

5

6

7

8

# DECK HARNESS - GENERAL LAYOUT

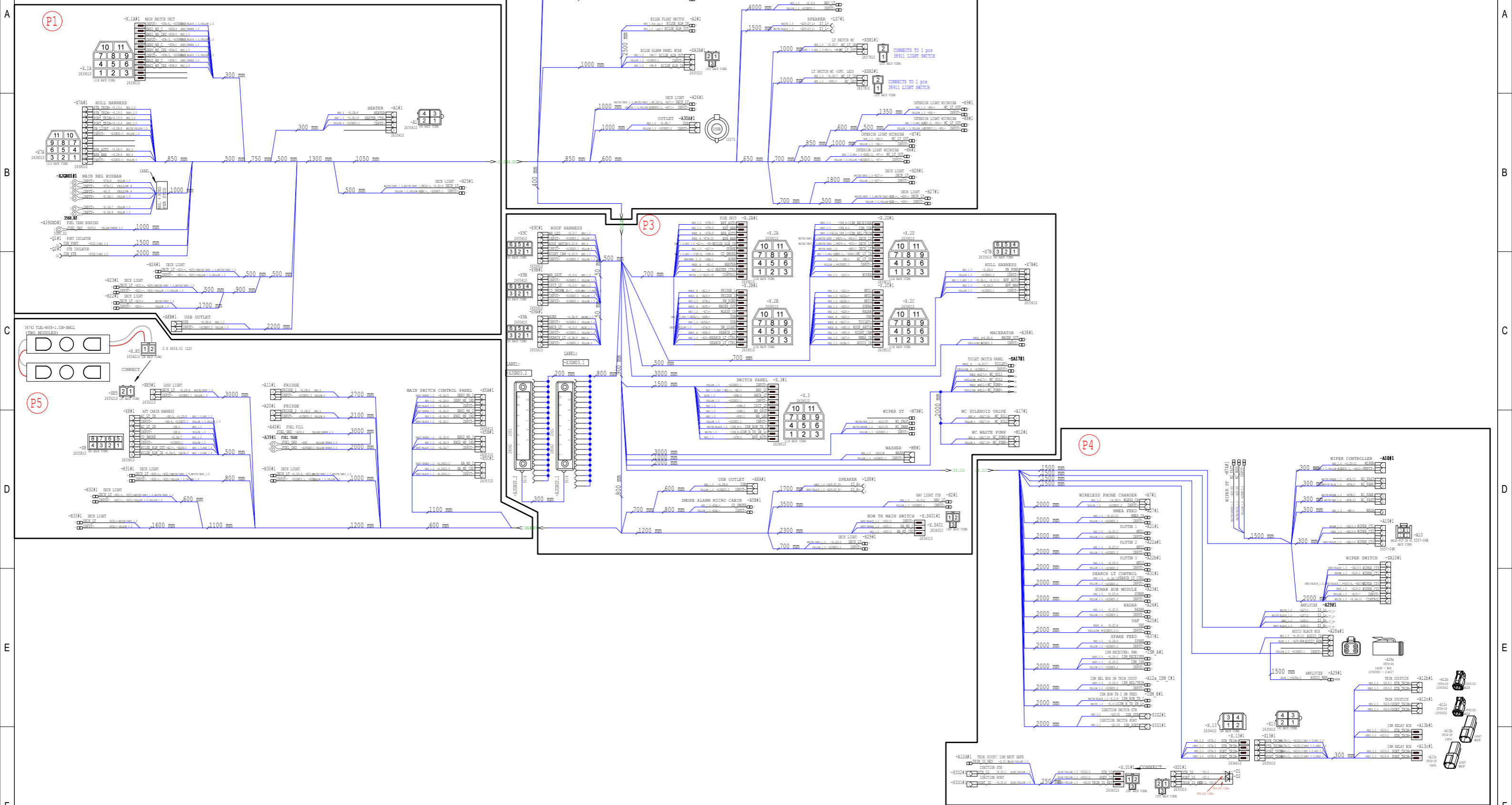

			Date	24.4.2023	Axopar		38690		2004468	
			Drawing by	PF	Boat		Product code		Project ID	
			Sheet rev.	1	28 MK3		DECK HARNESS		HL	
			Project rev.	A	Boat model		Title		Loc	
Date of modification	Modified by	Description							26 / Sheet	
1										
2										
3										
4										
5										
6										
7										
8										



P1

**-X.1A#1 MAIN SWITCH UNIT**

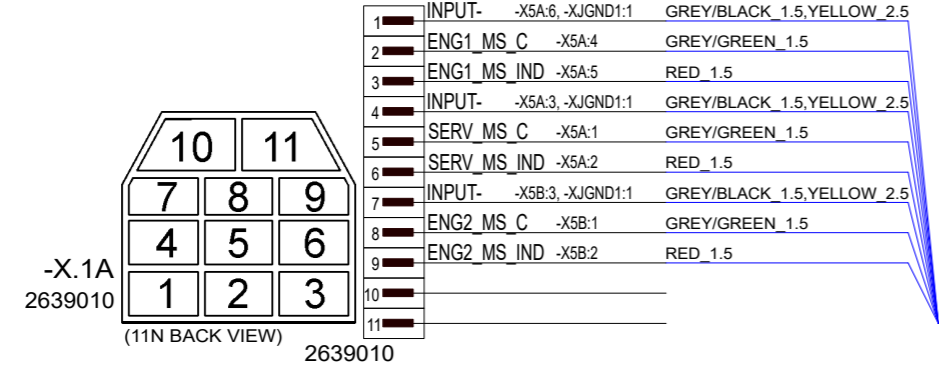

**-X7A#1 HULL HARNESS**

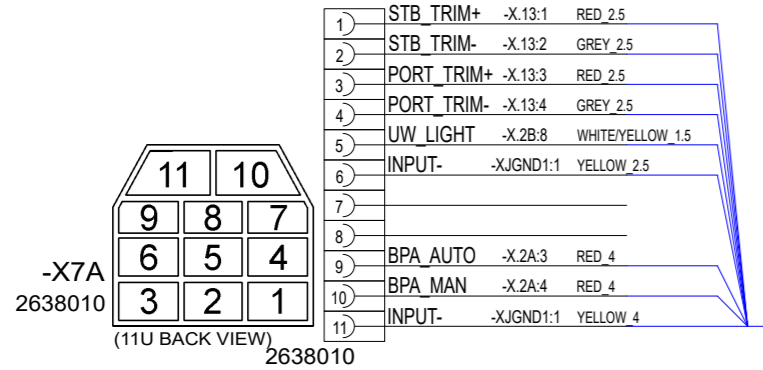

**HEATER -A1#1**

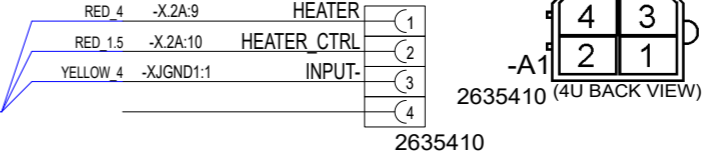

**-XJGND1#1 MAIN NEG BUSBAR**

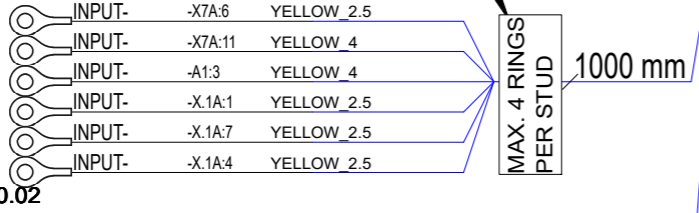

**-A39GND#1 FUEL TANK BONDING**



**-Q1#1 PORT ISOLATOR**

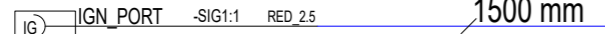

**-Q2#1 STB ISOLATOR**

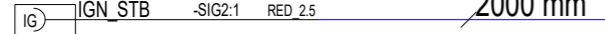

**-H24#1 DECK LIGHT**

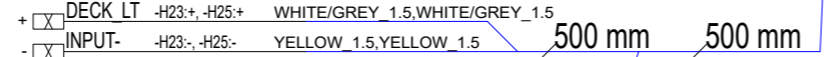

**-H23#1 DECK LIGHT**

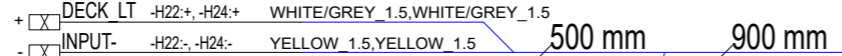

**-H22#1 DECK LIGHT**



**-A8B#1 USB OUTLET**

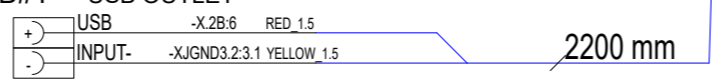

/28.E1

			Date	24.4.2023		Axopar		38690		2004468		
			Drawing by	PF		Boat	28 MK3		Product code		Project ID	
			Sheet rev.	1		Boat model			Title		HL	
Date of modification	Modified by	Description	Project rev.	A		Copyright by			DECK HARNESS		27 / Sheet	
1	2	3	4	5	6	7	8					

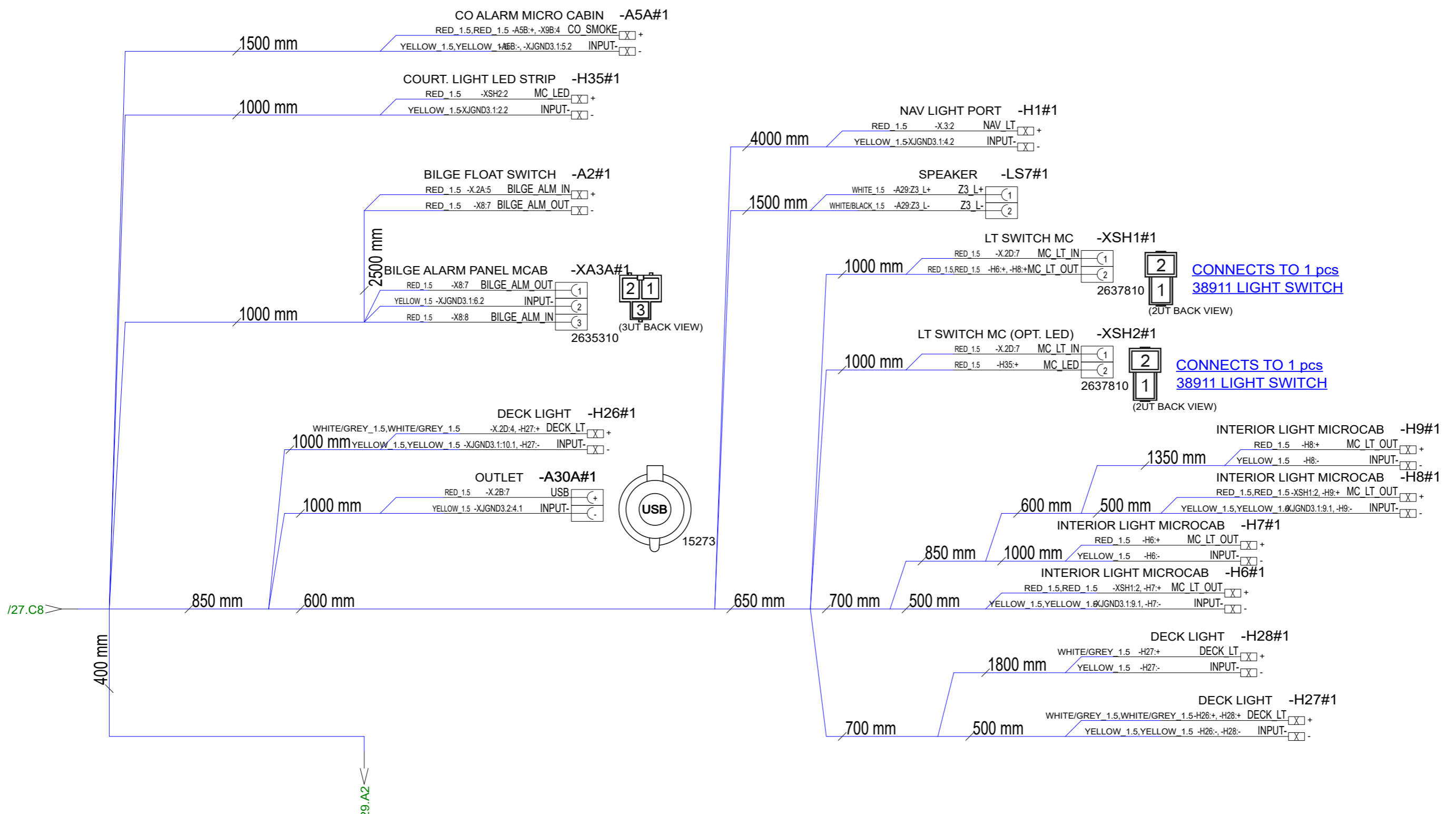

			Date	24.4.2023		Axopar		38690		2004468		
			Drawing by	PF		Boat	28 MK3		Product code		Project ID	
			Sheet rev.	1		Boat model		DECK HARNESS		HL		28 / Sheet
Date of modification	Modified by	Description	Project rev.	A		Title		Loc				

P3

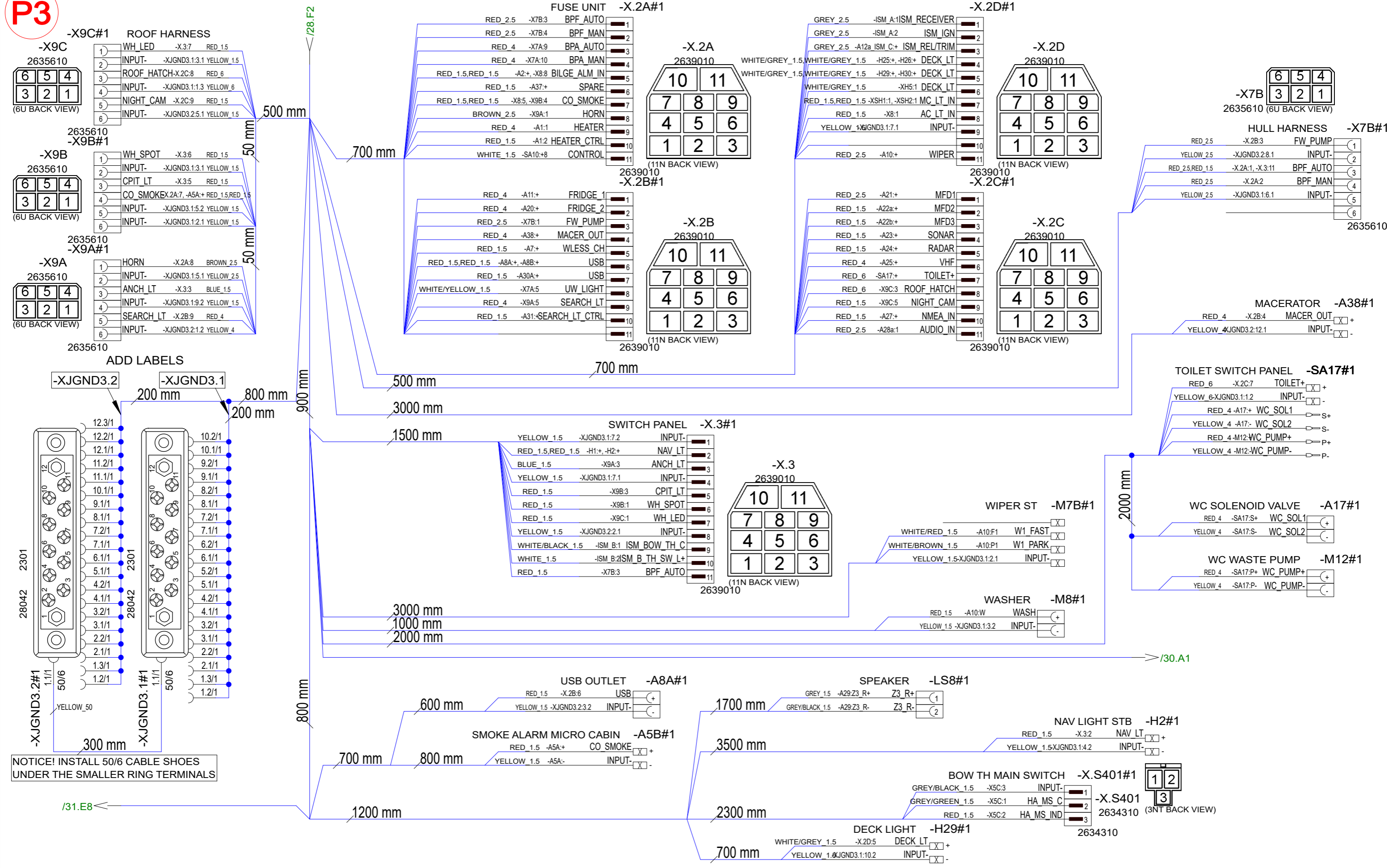

			Date	24.4.2023			Axopar					
			Drawing by	PF			Boat		38690		2004468	
			Sheet rev.	1			28 MK3		Sub-product code		Product code	
			Project rev.	A			Boat model		DECK HARNESS		HL	
Date of modification	Modified by	Description				Copyright by			Title		Loc	
1	2	3	4	5	6	7	8			29 / Sheet		

P4

/29.E7

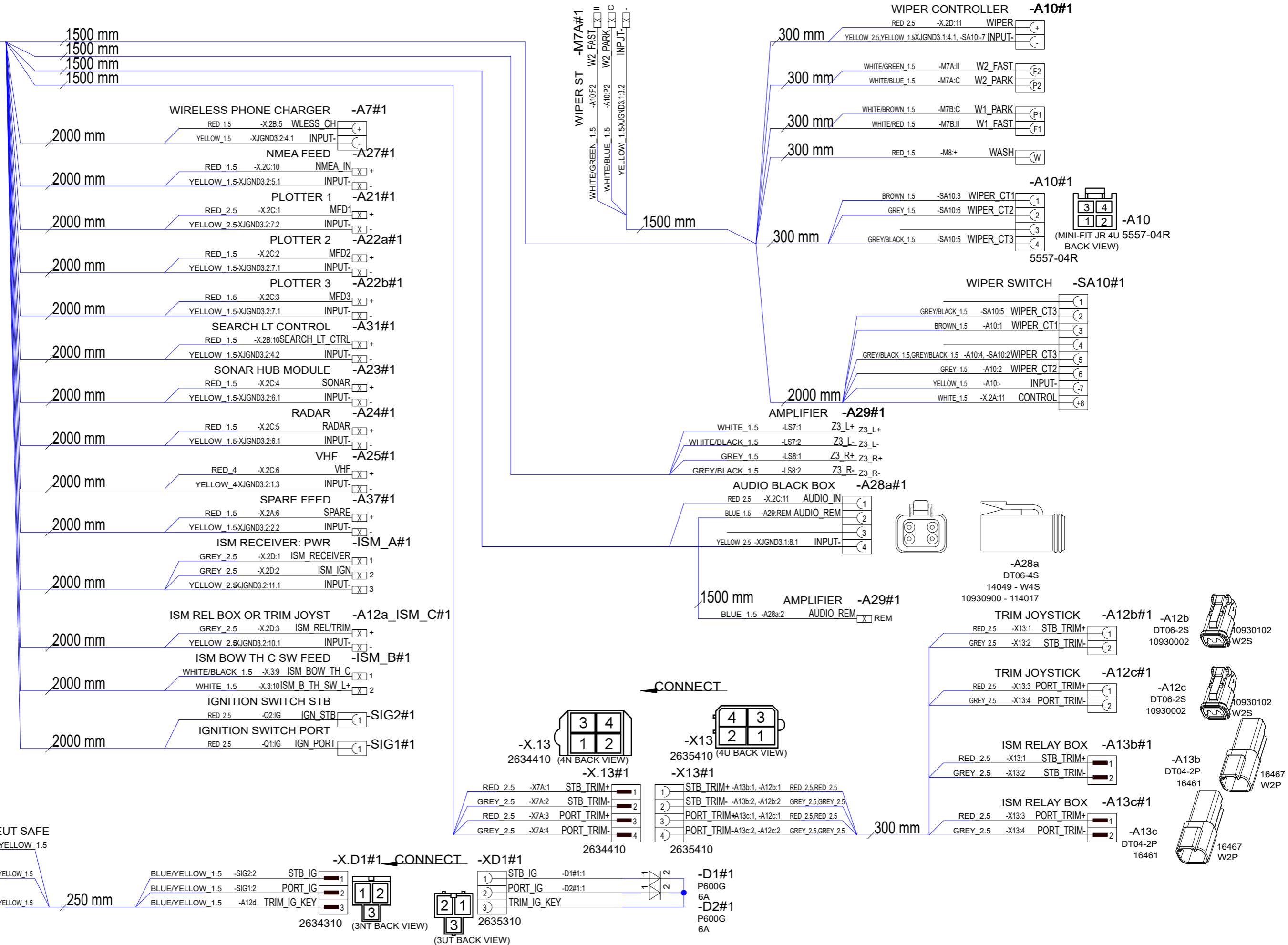

Date of modification	Modified by	Description

Date	24.4.2023		Axopar	<b>38690</b> Product code <b>2004468</b> Project ID						
Drawing by	PF		Boat		28 MK3					
Sheet rev.	1		Boat model		28 MK3					
Project rev.	A		Copyright by		NAVIX					
<table border="1"> <tr> <td>Sub-product code</td> <td>DECK HARNESS</td> </tr> <tr> <td>Loc</td> <td>HL</td> </tr> </table>			Sub-product code	DECK HARNESS	Loc	HL	<table border="1"> <tr> <td>30 /</td> </tr> <tr> <td>Sheet</td> </tr> </table>		30 /	Sheet
Sub-product code	DECK HARNESS									
Loc	HL									
30 /										
Sheet										

P5

WHITE = INPUT-  
WHITE/RED = INPUT+

36792 TLBL-W65K-1.32W-SMALL  
(TWO MODULES)

2 X 6434.01 (LU)

-X.H5  
2634210 (2N BACK VIEW)

CONNECT

-X.H5  
2635210 (2U BACK VIEW)

-XH5#1 LOGO LIGHT

1) DECK LT -X.2D:6 WHITE/GREY 1.5  
2) INPUT- -XJGND3.2:11.2 YELLOW 1.5

3000 mm

-X8#1 AFT CABIN HARNESS

1) AC LT IN -X8:3,-X.2D:8 RED 1.5,RED 1.5  
2) INPUT- -X8:4,-XJGND3.1:8.2 YELLOW 1.5,YELLOW 1.5  
3) AC LT IN -X8:1 RED 1.5  
4) INPUT- -X8:2 YELLOW 1.5  
5) CO SMOKE -X.2A:7 RED 1.5  
6) INPUT- -XJGND3.1:8.2 YELLOW 1.5  
7) BILGE ALM OUT -A2:-, -XA3A:1 RED 1.5,RED 1.5  
8) BILGE ALM IN -X.2A:5,-XA3A:3 RED 1.5,RED 1.5

500 mm

-X8  
2635810 (8U BACK VIEW)

2635810

-H31#1 DECK LIGHT

+ [X] DECK LT -H30+,-H32+ WHITE/GREY 1.5,WHITE/GREY 1.5  
- [X] INPUT- -H30:-,-H32:- YELLOW 1.5,YELLOW 1.5

800 mm

-H32#1 DECK LIGHT

+ [X] DECK LT -H31+,-H33+ WHITE/GREY 1.5,WHITE/GREY 1.5  
- [X] INPUT- -H31:-,-H33:- YELLOW 1.5,YELLOW 1.5

600 mm

-H33#1 DECK LIGHT

+ [X] DECK LT -H32+ WHITE/GREY 1.5  
- [X] INPUT- -H32:- YELLOW 1.5

1600 mm

1100 mm

-A11#1 FRIDGE

+ FRIDGE 1 -X.2B:1 RED 4  
- INPUT- -XJGND3.2:12.3 YELLOW 4

2700 mm

-A20#1 FRIDGE

+ FRIDGE 2 -X.2B:2 RED 4  
- INPUT- -XJGND3.2:12.2 YELLOW 4

2100 mm

-A40#1 FUEL FILL

FUEL\_GND -A39:1 YELLOW/GREEN 2.5

3000 mm

-A39#1 FUEL TANK

1) FUEL\_GND -A40 YELLOW/GREEN 2.5  
2) FUEL\_GND -A39GND:1 YELLOW/GREEN 2.5

2000 mm

-H30#1 DECK LIGHT

+ [X] DECK LT -X.2D:5,-H31+ WHITE/GREY 1.5,WHITE/GREY 1.5  
- [X] INPUT- -XJGND3.2:11.2,-H31:- YELLOW 1.5,YELLOW 1.5

1000 mm

MAIN SWITCH CONTROL PANEL -X5A#1

GREY/GREEN 1.5 -X.1A:5 SERV\_MS\_C (1)  
RED 1.5 -X.1A:6 SERV\_MS\_IND (2)  
GREY/BLACK 1.5 -X.1A:4 INPUT- (3)  
GREY/GREEN 1.5 -X.1A:2 ENG1\_MS\_C (4)  
RED 1.5 -X.1A:3 ENG1\_MS\_IND (5)  
GREY/BLACK 1.5 -X.1A:1 INPUT- (6)

-X5A  
2635610 (6U BACK VIEW)

2635610  
-X5B#1

2 1

-X5B  
2635310 (3UT BACK VIEW)

GREY/GREEN 1.5 -X.1A:8 ENG2\_MS\_C (1)  
RED 1.5 -X.1A:9 ENG2\_MS\_IND (2)  
GREY/BLACK 1.5 -X.1A:7 INPUT- (3)

2635310  
-X5C#1

2 1

-X5C  
2635310 (3UT BACK VIEW)

GREY/GREEN 1.5 -X.S401:2 HA\_MS\_C (1)  
RED 1.5 -X.S401:3 HA\_MS\_IND (2)  
GREY/BLACK 1.5 -X.S401:1 INPUT- (3)

2635310

1100 mm

600 mm

/29.F1

Date 24.4.2023

Drawing by PF

Sheet rev. 1

Project rev. A

NAVIX

Copyright by

Axopar

Boat

28 MK3

Boat model

Sub-product code

DECK HARNESS

Title

38690  
Product code

HL

Loc

2004468  
Project ID

31/  
Sheet

Date of modification Modified by Description

1

2

3

4

5

6

7

8

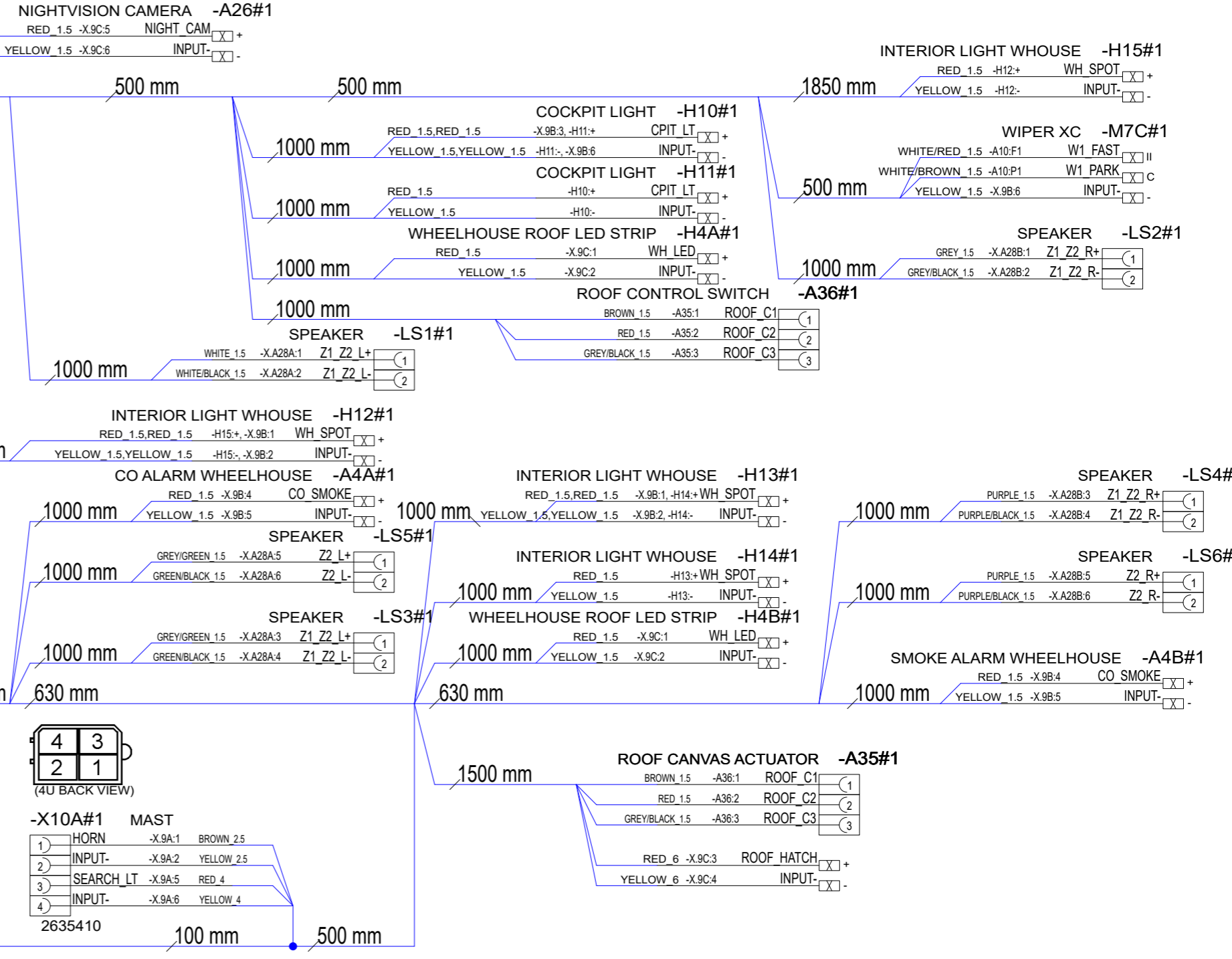
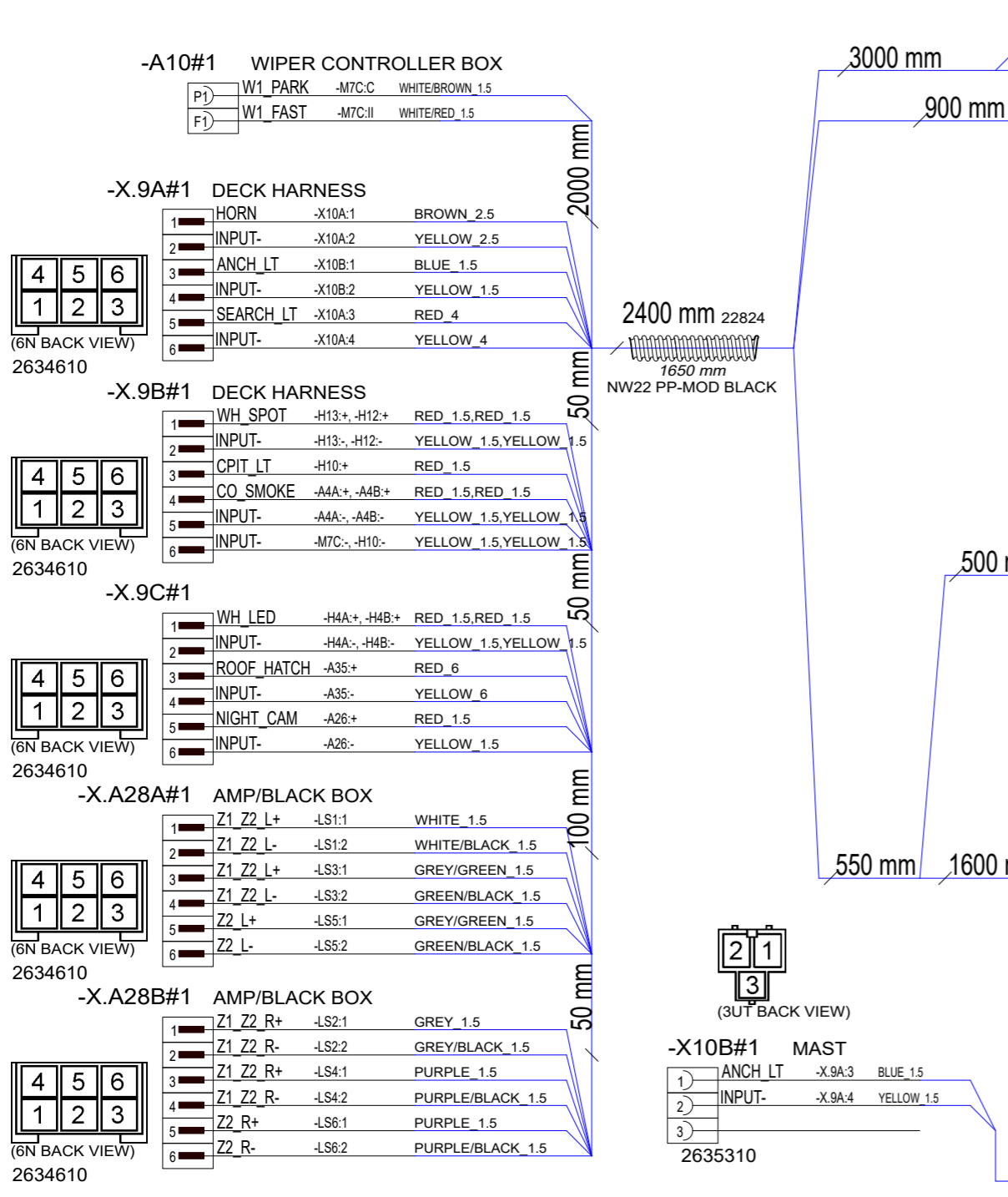
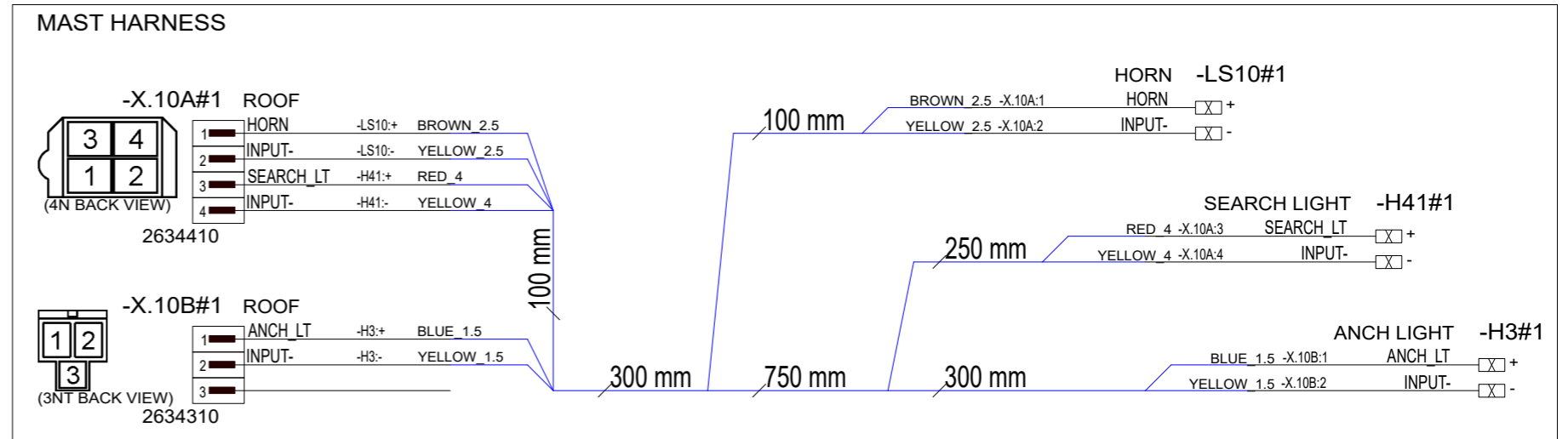
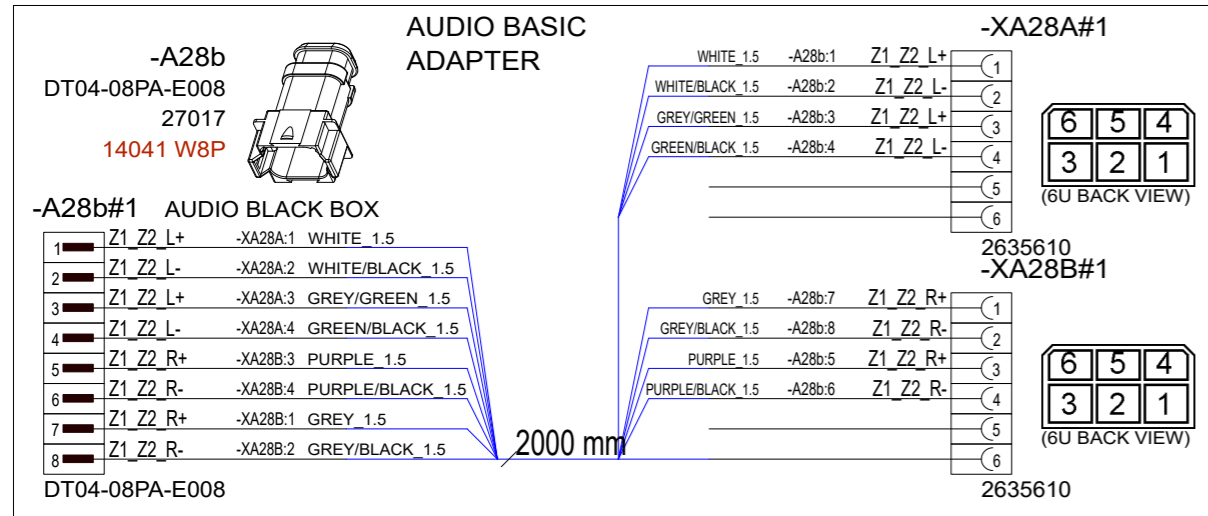

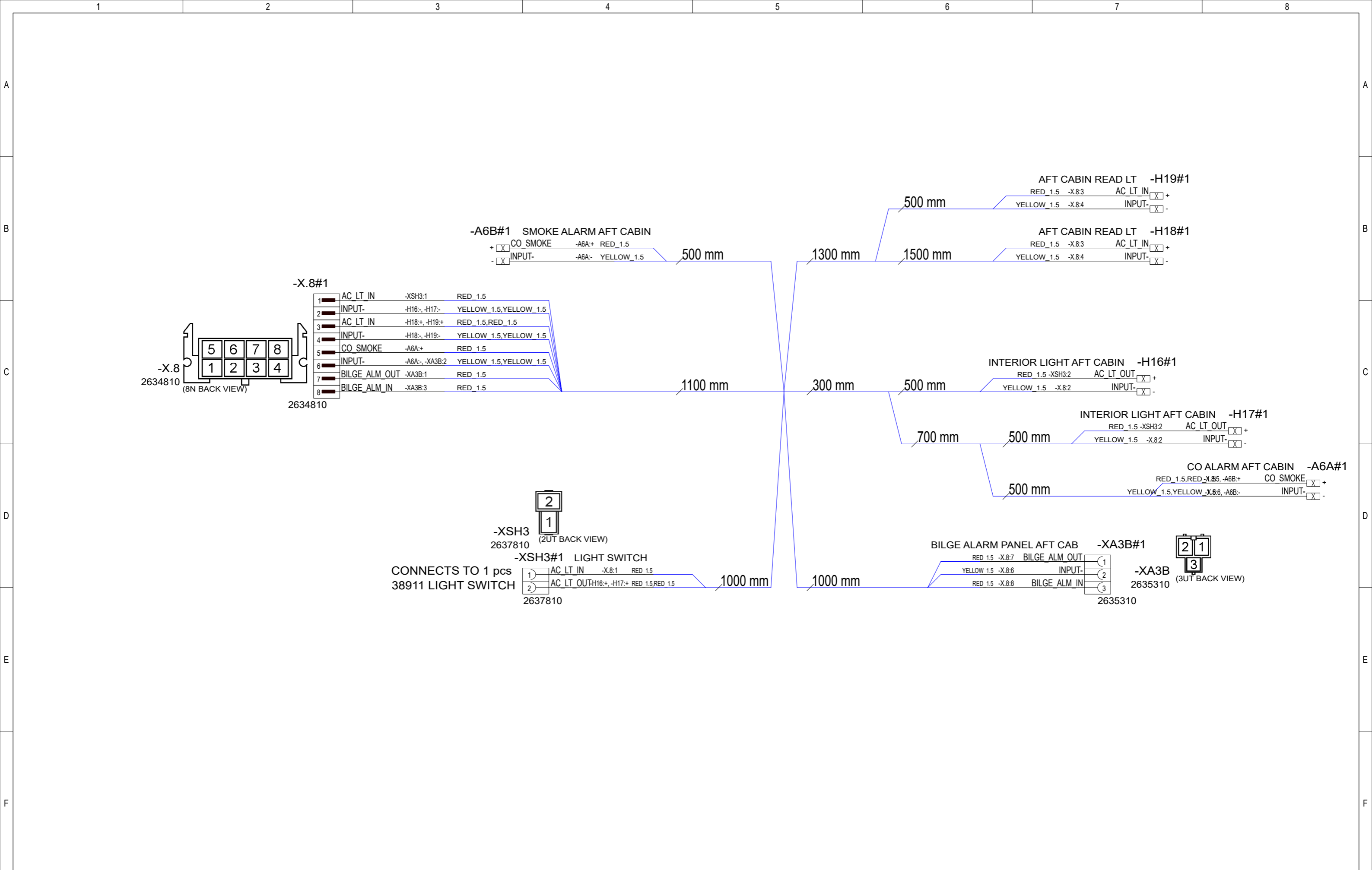

			Date	27.3.2023	Axopar		38692		2004468	
			Drawing by	PF	Boat		Sub-product code		Product code	
			Sheet rev.	1	28 MK3		AFT CABIN HARNESS		HL	
Date of modification	Modified by	Description	Project rev.	A	Copyright by	Boat model	Title	Loc	33 / Sheet	
1	2	3	4	5	6	7	8			

CONNECTS TO FOLLOWING

38290 DECK HARNESS (1-2 PCS)

38292 AFT CABIN HARNESS (1 PCS)

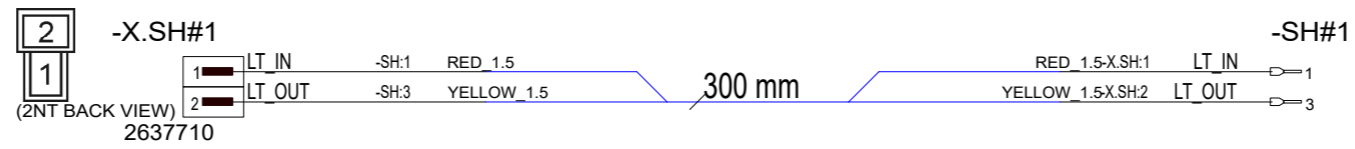
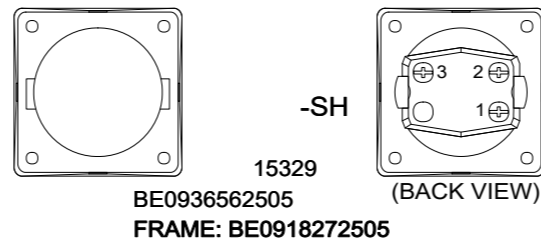

Date 26.4.2023

Drawing by PF

Sheet rev. 1

Project rev. A

NAVIX

Copyright by

Axopar

Boat

28 MK3

Boat model

Sub-product code

LIGHT SWITCH

Title

38911

Product code

HL

Loc

2004468

Project ID

34 /  
Sheet



NOTICE! CABLES WITH STICKER

FOR EXAMPLE  
POINT -A-



LABEL:  
-Q1

INCLUDED:  
38826

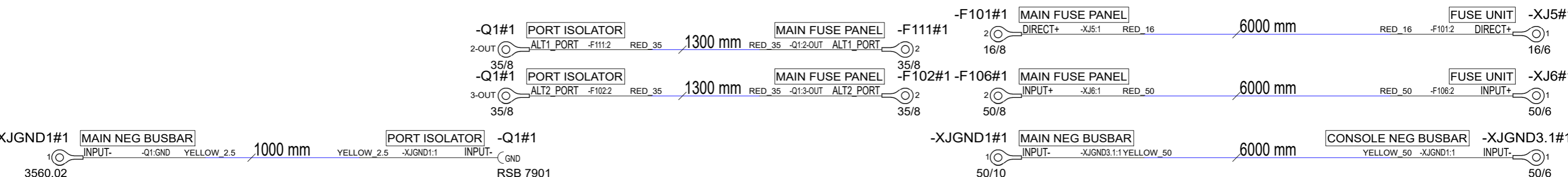
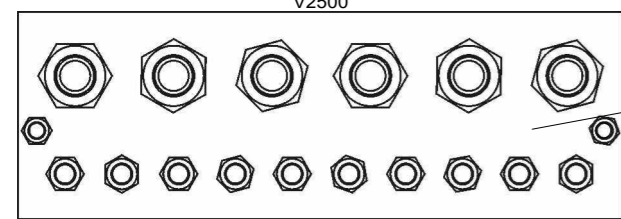
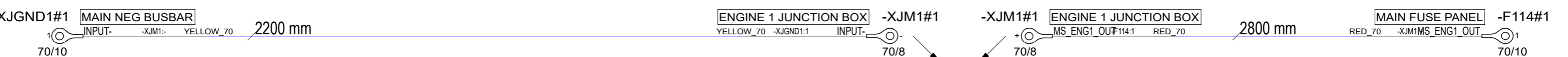
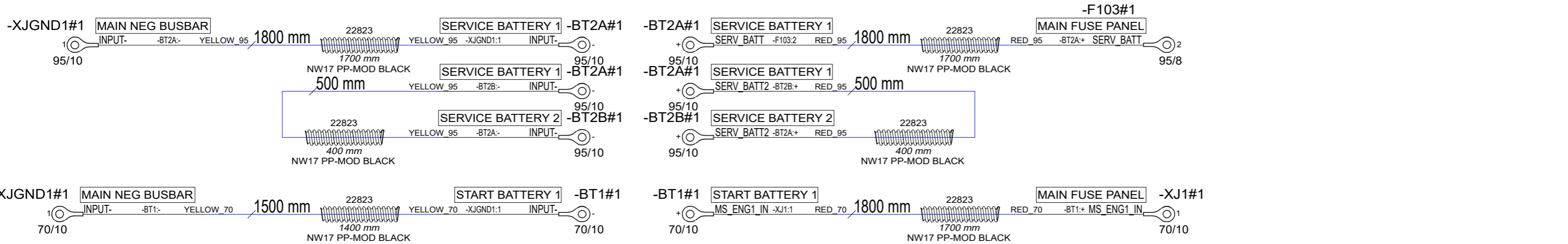
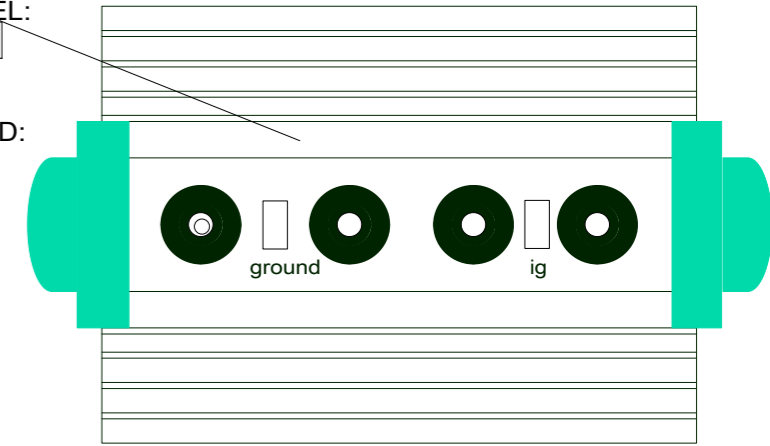

			Date	20.3.2023			Axopar					
			Drawing by	PF			Boat		38677		2004468	
			Sheet rev.	1			28 MK3		Sub-product code		Product code	
			Project rev.	A	Copyright by		Boat model		BATTERY CABLES		HL	
Date of modification	Modified by	Description						Title		Loc		35 / Sheet
1	2	3	4	5	6	7	8					

NOTICE! CABLES WITH STICKER

FOR EXAMPLE  
POINT -A-



CUSTOMER INSTALLS TO  
38687 MAIN SWITCH CONTROL PANEL

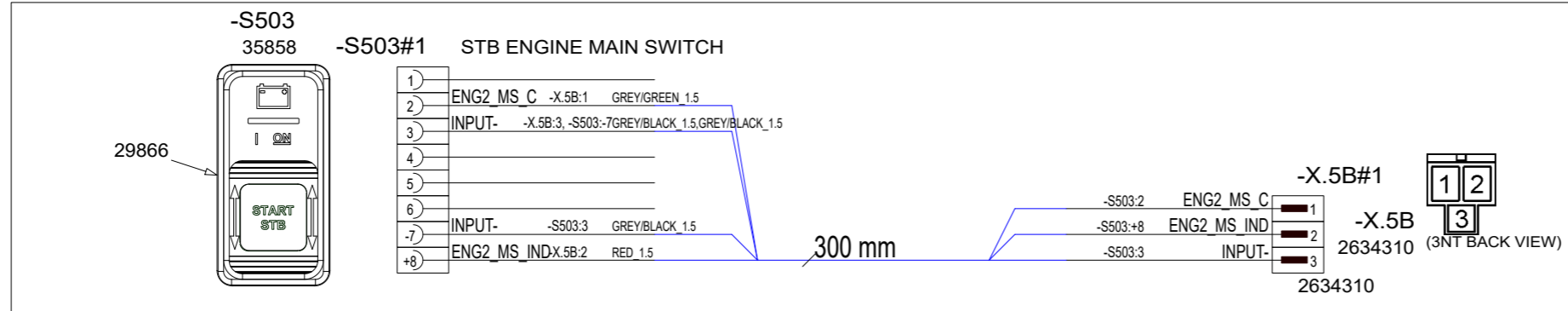

LABEL:  
-Q2

INCLUDED:  
38826

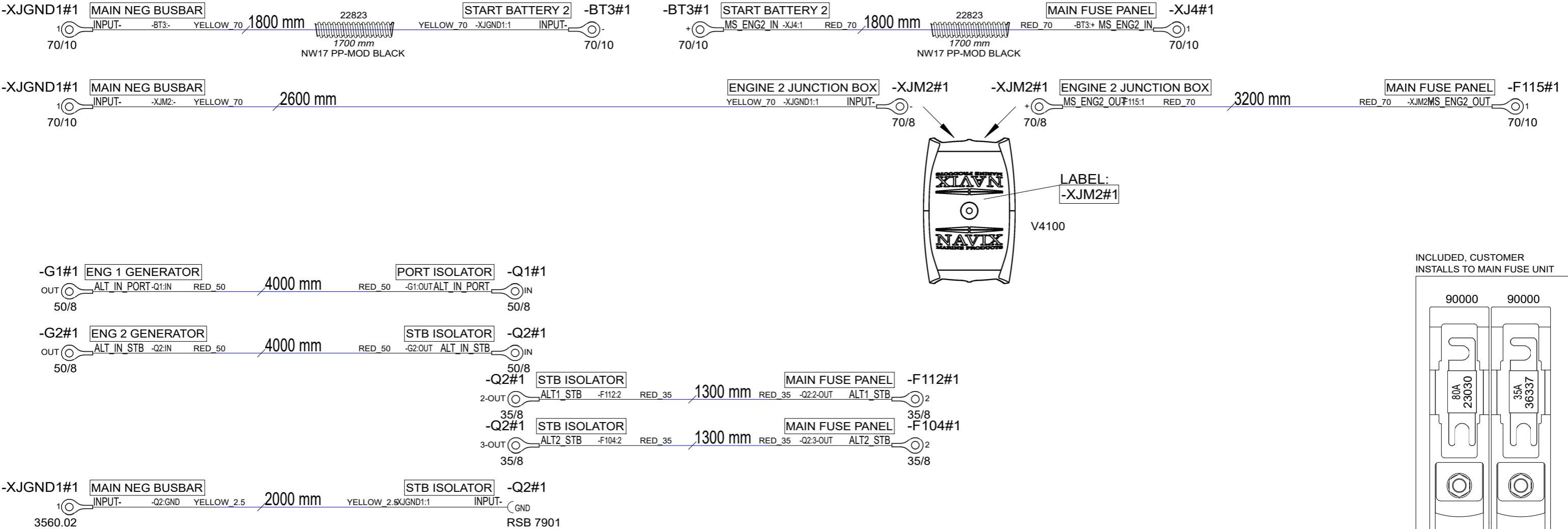
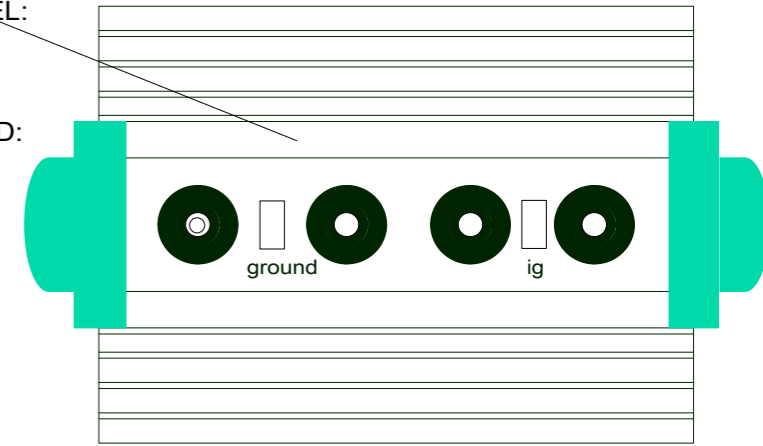

INCLUDED, CUSTOMER  
INSTALLS TO MAIN FUSE UNIT

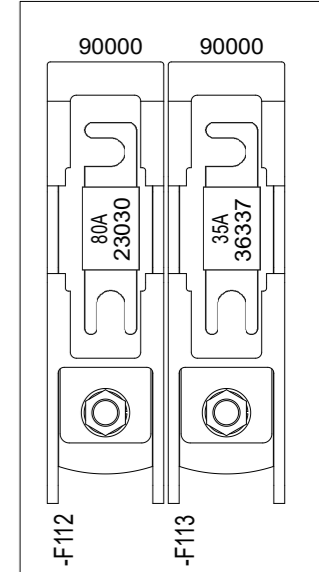

			Date	20.3.2023	Axopar		38678		2004468	
			Drawing by	PF	Boat		Product code		Project ID	
			Sheet rev.	1	28 MK3		Sub-product code		HL	
			Project rev.	A	Boat model		Title		Loc	
Date of modification	Modified by	Description					DUAL ENGINE BATTERY CABLES			36 / Sheet

NOTICE! CABLES WITH STICKER

FOR EXAMPLE  
POINT -A-

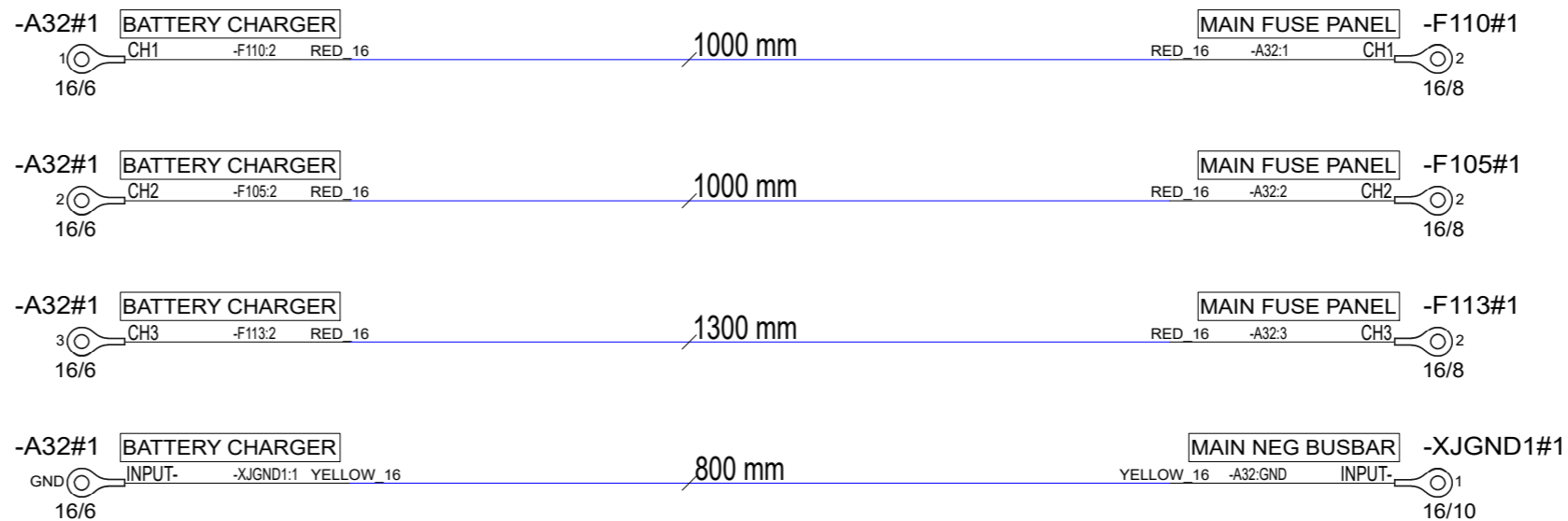

			Date	20.3.2023	Axopar		38679		2004468	
			Drawing by	PF	Boat		Product code		Project ID	
			Sheet rev.	1	28 MK3		CHARGER CABLES		HL	
Date of modification	Modified by	Description	Project rev.	A	Copyright by	Boat model	Title	Loc	37 / Sheet	
1	2	3	4	5	6	7	8			

NOTICE! CABLES WITH STICKER

FOR EXAMPLE  
POINT -A-

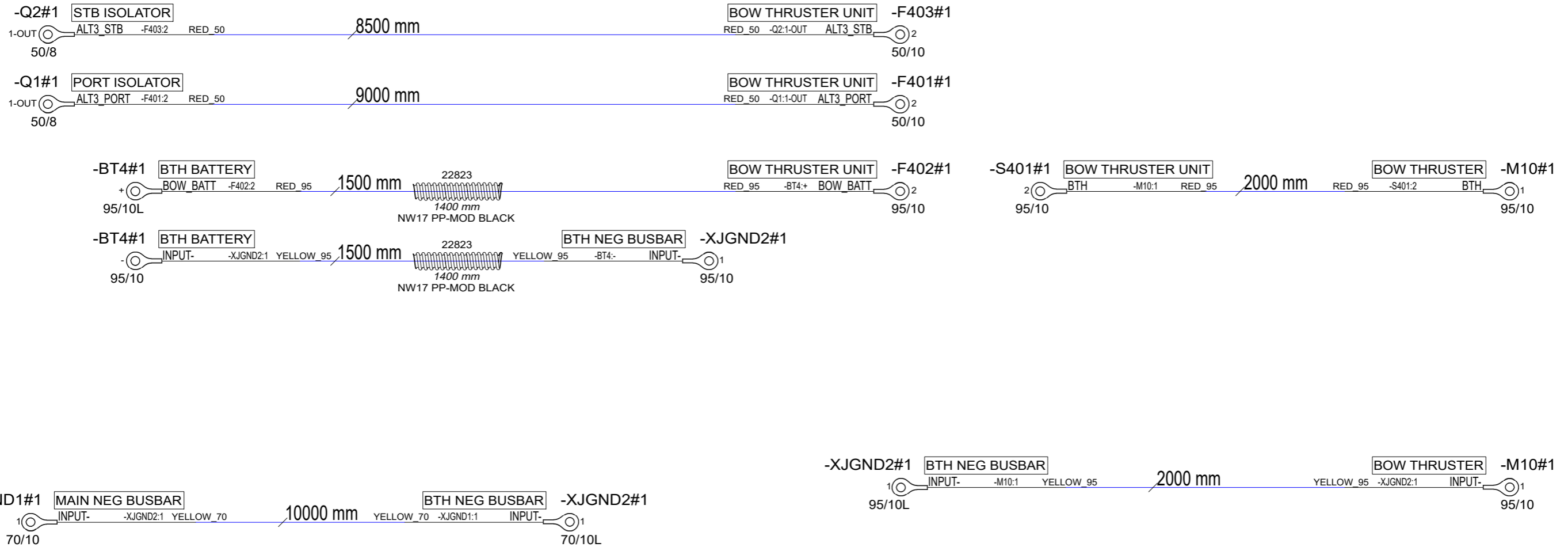

Date 22.3.2023

Drawing by PF

Sheet rev. 1

Project rev. A



Copyright by

Axopar

Boat  
28 MK3

Boat model

Sub-product code  
**BOW THRUSTER  
CABLES**  
Title

38680  
Product code

HL  
Loc

2004468  
Project ID

38 /  
Sheet

Date of modification	Modified by	Description	Date	Drawing by	Sheet rev.	Project rev.	Boat	Boat model	Sub-product code	Product code	Project ID	HL	Loc	Sheet
1			22.3.2023	PF	1	A	28 MK3		BOW THRUSTER CABLES	38680	2004468	HL		38 /

NOTICE! CABLES WITH STICKER

FOR EXAMPLE  
POINT -A-

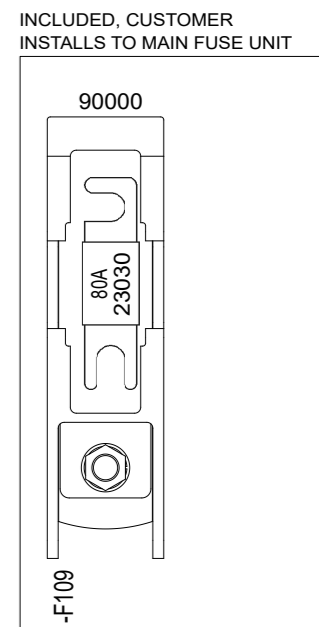
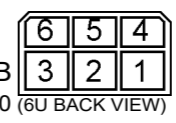
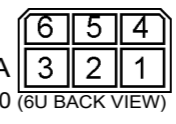
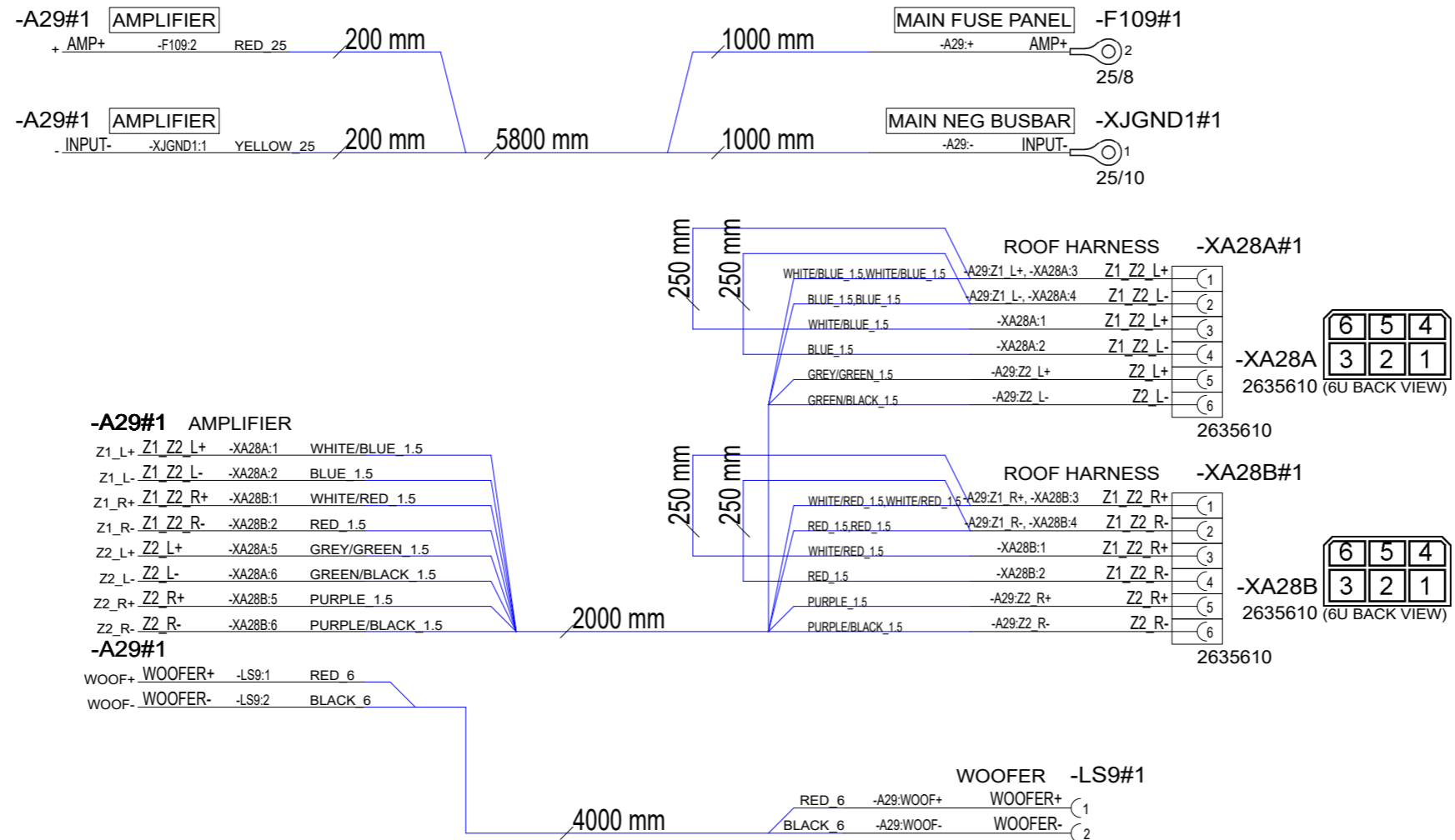

			Date	23.3.2023	Axopar		38681		2004468	
			Drawing by	PF	Boat		Product code		Project ID	
			Sheet rev.	1	28 MK3		AUDIO UPGRADE		HL	
			Project rev.	A	Boat model		CABLES		Loc	
Date of modification	Modified by	Description					Title		39 / Sheet	

NOTICE! CABLES WITH STICKER

FOR EXAMPLE  
POINT -A-



**-Q3**  
23655  
Battery Combiner 80A, 2 batteries  
Victron BCD 802

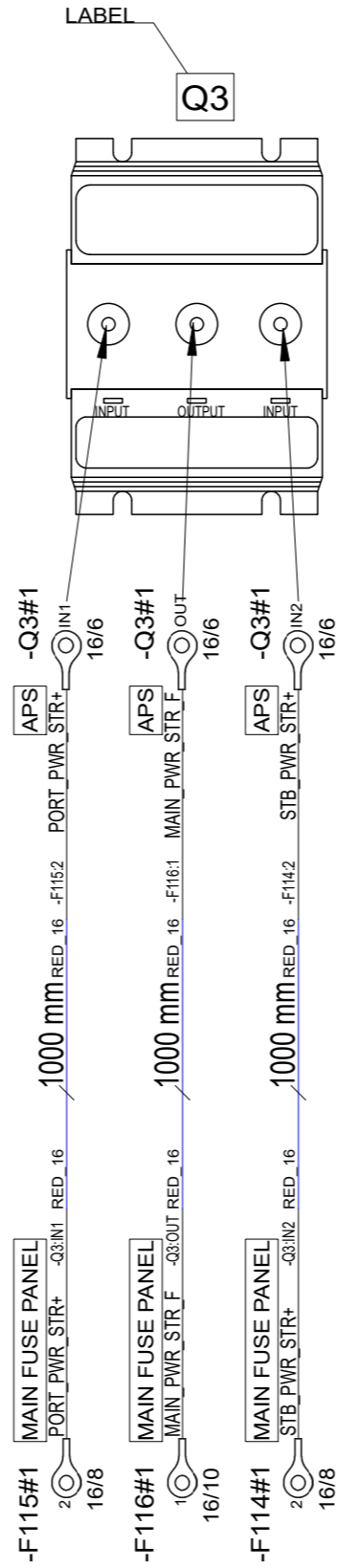

Date 3.4.2023

Drawing by PF

Sheet rev. 1

Project rev. A



Copyright by

Axopar

Boat

28 MK3

Boat model

Sub-product code

POWER STEER  
CABLES NO JPO

38698

Product code

HL

Loc

2004468

Project ID

40 /  
Sheet

Date of modification Modified by Description

1

2

3

4

5

6

7

8

NOTICE! CABLES WITH STICKER

FOR EXAMPLE  
POINT -A-



INCLUDED, CUSTOMER  
INSTALLS TO BOW THRUSTER UNIT

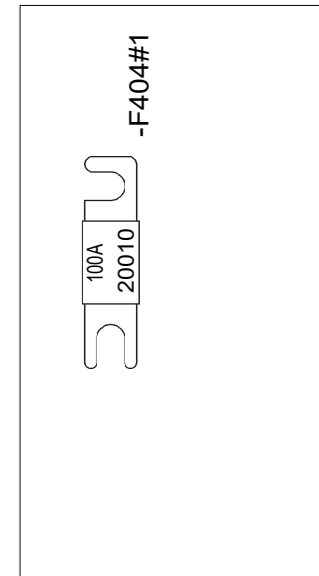

			Date	3.4.2023	Axopar		38699		2004468	
			Drawing by	PF	Boat		Product code		Project ID	
			Sheet rev.	1	28 MK3		BOW ANCHOR WINCH CABLES		HL	
Date of modification	Modified by	Description	Project rev.	A	Copyright by	Boat model	Title	Loc	41/ Sheet	
1	2	3	4	5	6	7	8			

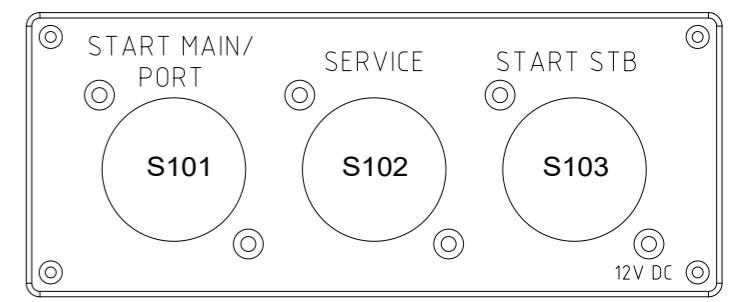
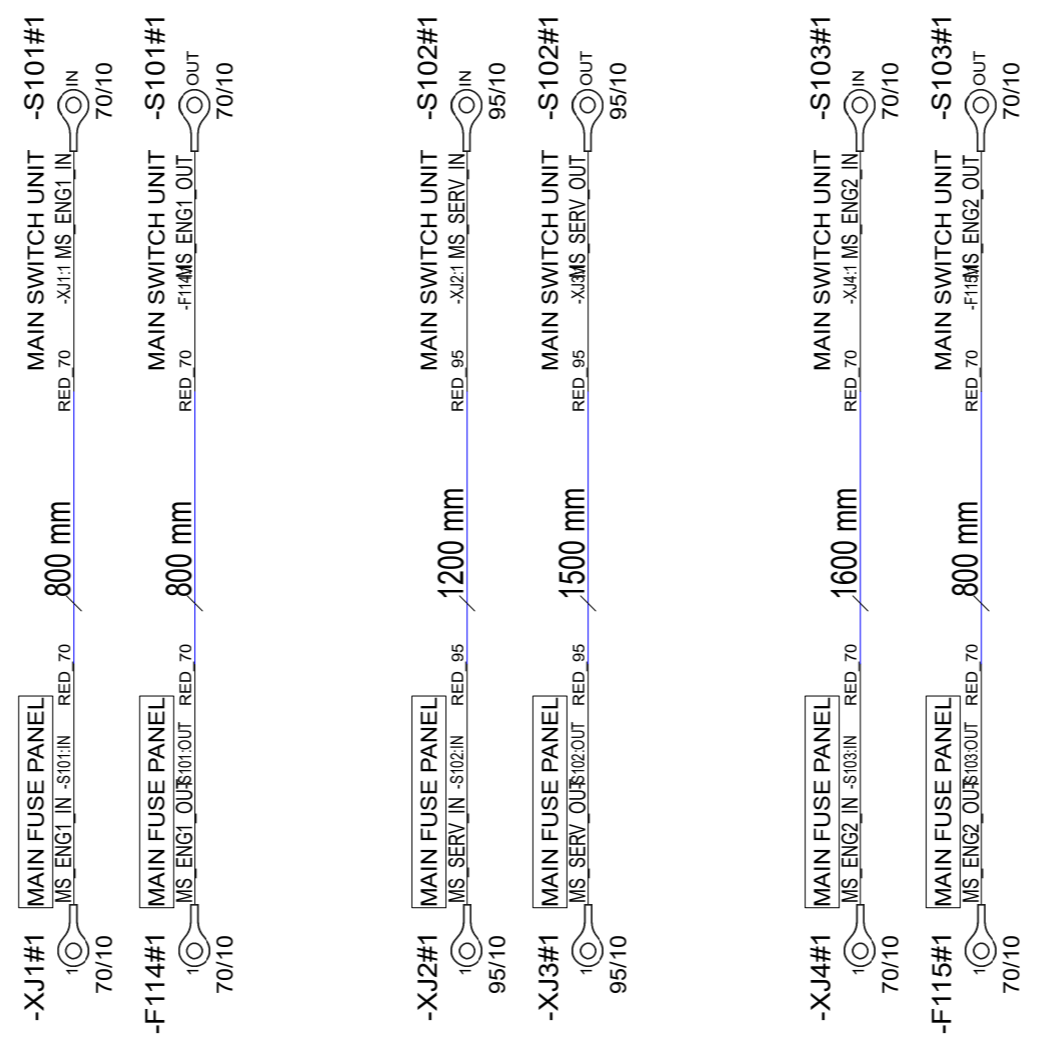
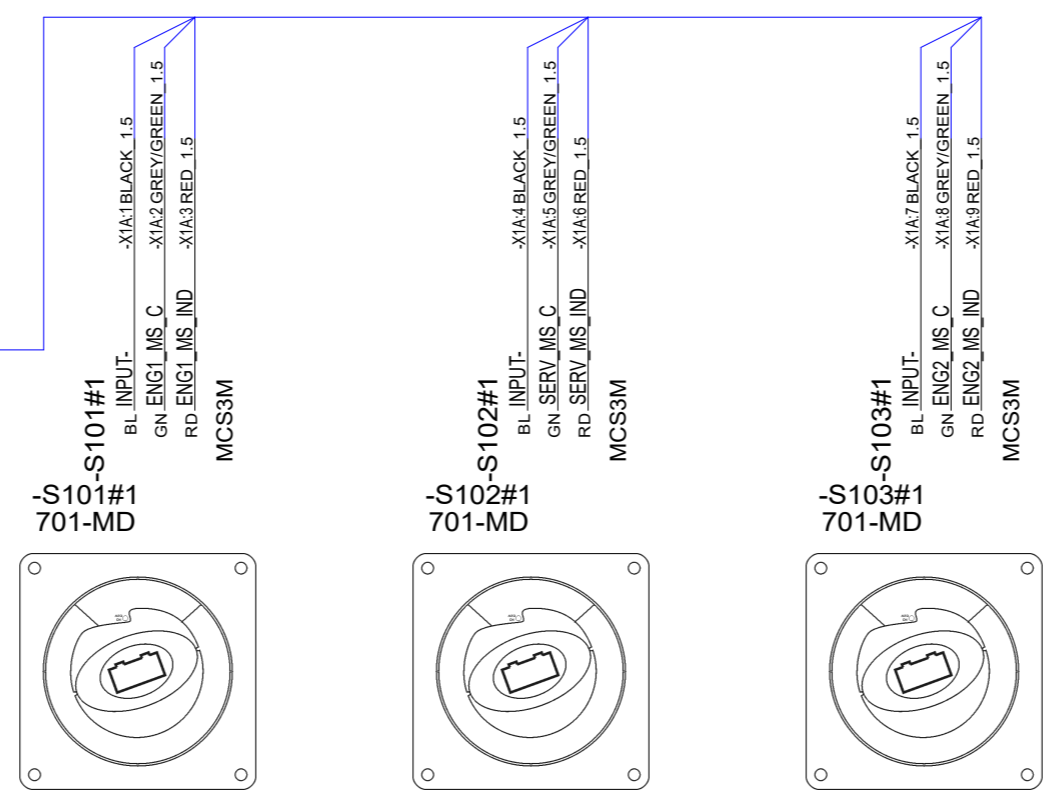
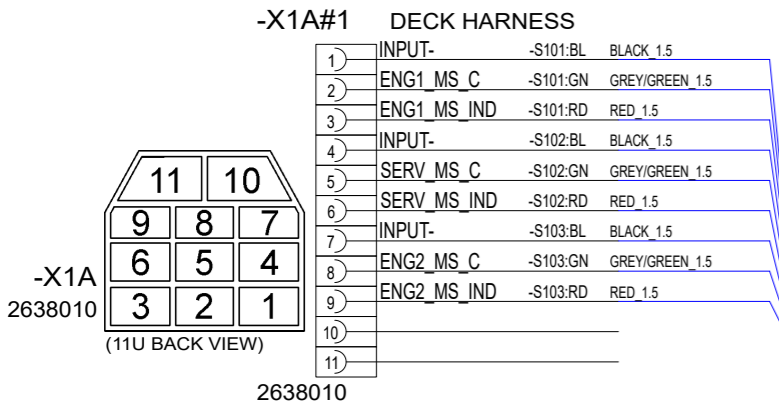

			Date	23.3.2023	Axopar		38682		2004468	
			Drawing by	PF	Boat		Sub-product code		Product code	
			Sheet rev.	1	28 MK3		MAIN SWITCH UNIT		HL	
Date of modification			Modified by		Boat model		REMOTE		Loc	
1			2		3		4		5	
6			7		8		42 /		Sheet	



Copyright by



38682\_AXOPAR\_28\_MAIN\_SWITCH\_UNIT\_REMOTE DUAL ENG.

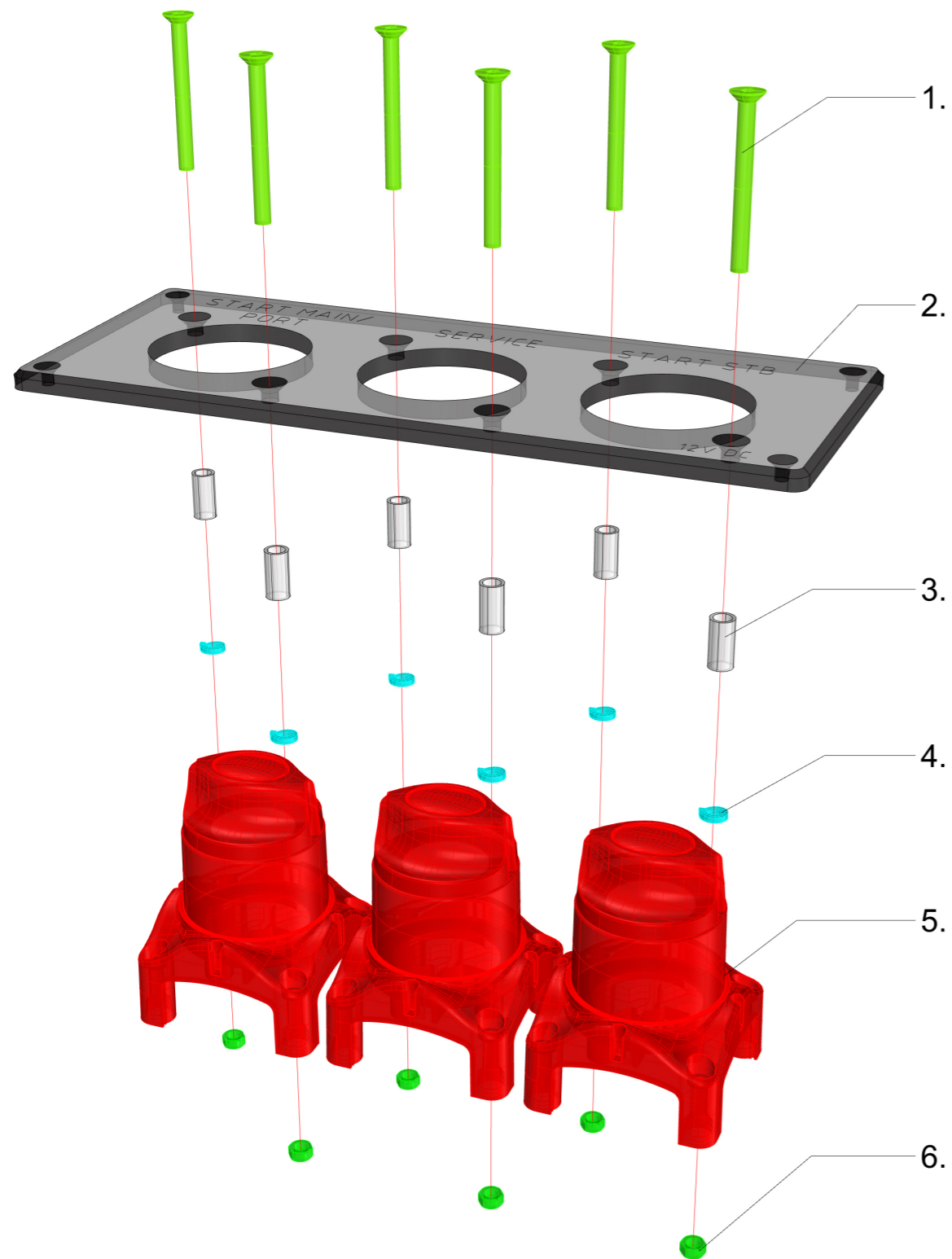

38682\_AXOPAR\_28\_MAIN\_SWITCH\_UNIT\_REMOTE DUAL ENG.

- 1. 6pcs VMI31811 - Countersunk head Screw HEX socket M5X50 DIN7991
- 2. 1pc 39053\_AXOPAR\_28\_MSU\_PANEL
- 3. 6pcs 6440 - HOLKKI NAVIX PÄÄKYTKIMEEN - halk. 8/6mm pituus 16mm
- 4. 6pcs VMI31540 - Spring Lock Washer M5 DIN127
- 5. 3pcs 14002110K Remote Controlled Battery Switch
- 6. 6pcs VMI31538 - HEX Nut M5 DIN934

16.05.-22 / TE

			Date	23.3.2023	Axopar		38682		2004468	
			Drawing by	PF	Boat		Sub-product code		Project ID	
			Sheet rev.	1	28 MK3		MAIN SWITCH UNIT		HL	
Date of modification	Modified by	Description	Project rev.	A	Boat model		REMOTE		Loc	
1		2	3	4	5	6	7	8	43 / Sheet	

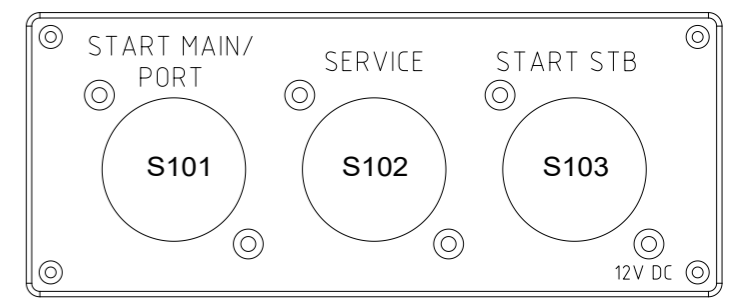
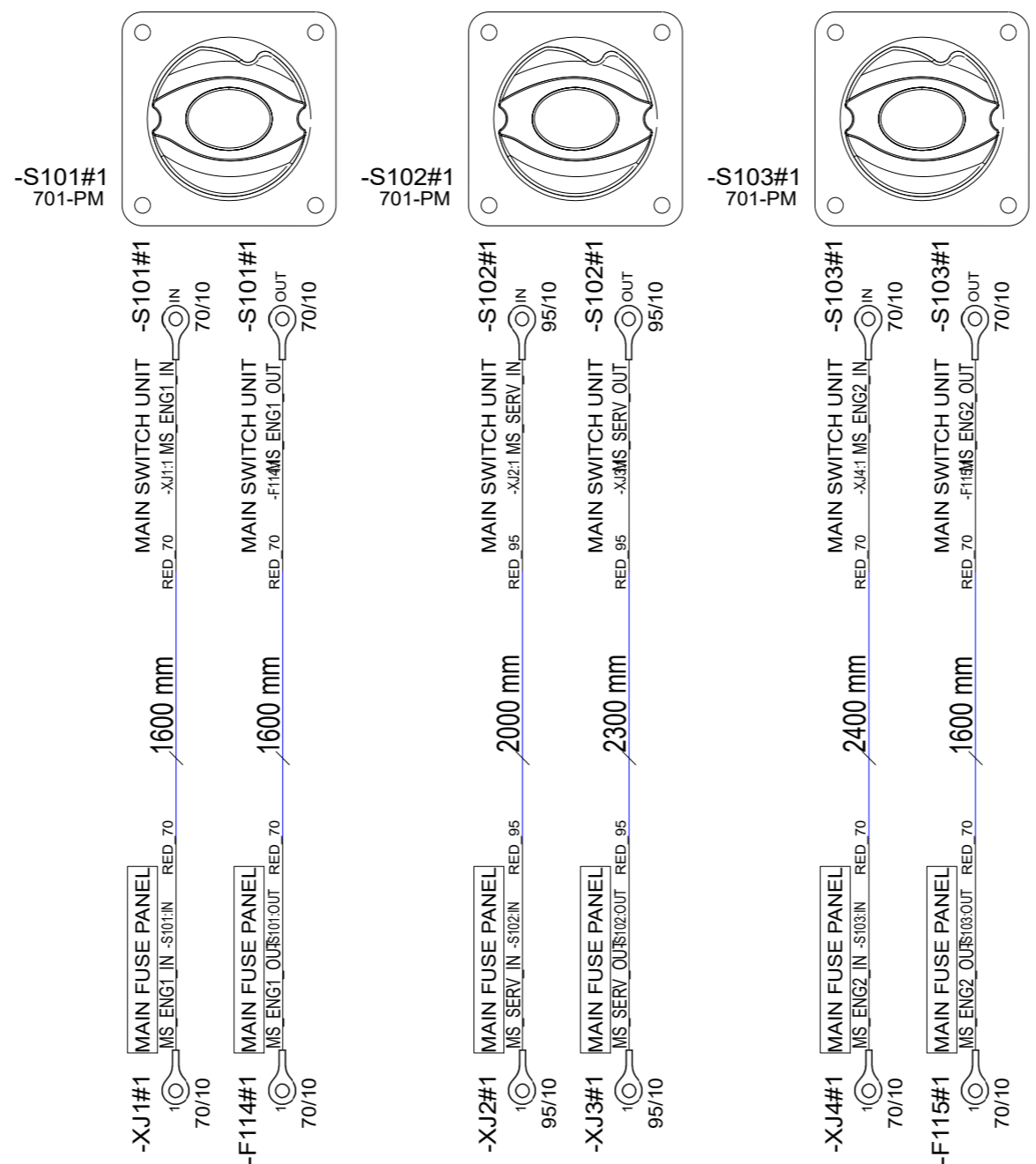

			Date	23.3.2023			Axopar					
			Drawing by	PF			Boat		Sub-product code		38683	
			Sheet rev.	1			28 MK3		MAIN SWITCH UNIT		2004468	
			Project rev.	A	Copyright by		Boat model		MANUAL		Project ID	
Date of modification	Modified by	Description								HL		44 / Sheet
1	2	3								Loc		

38683\_AXOPAR\_28\_MAIN\_SWITCH\_UNIT\_MANUAL DUAL ENG.

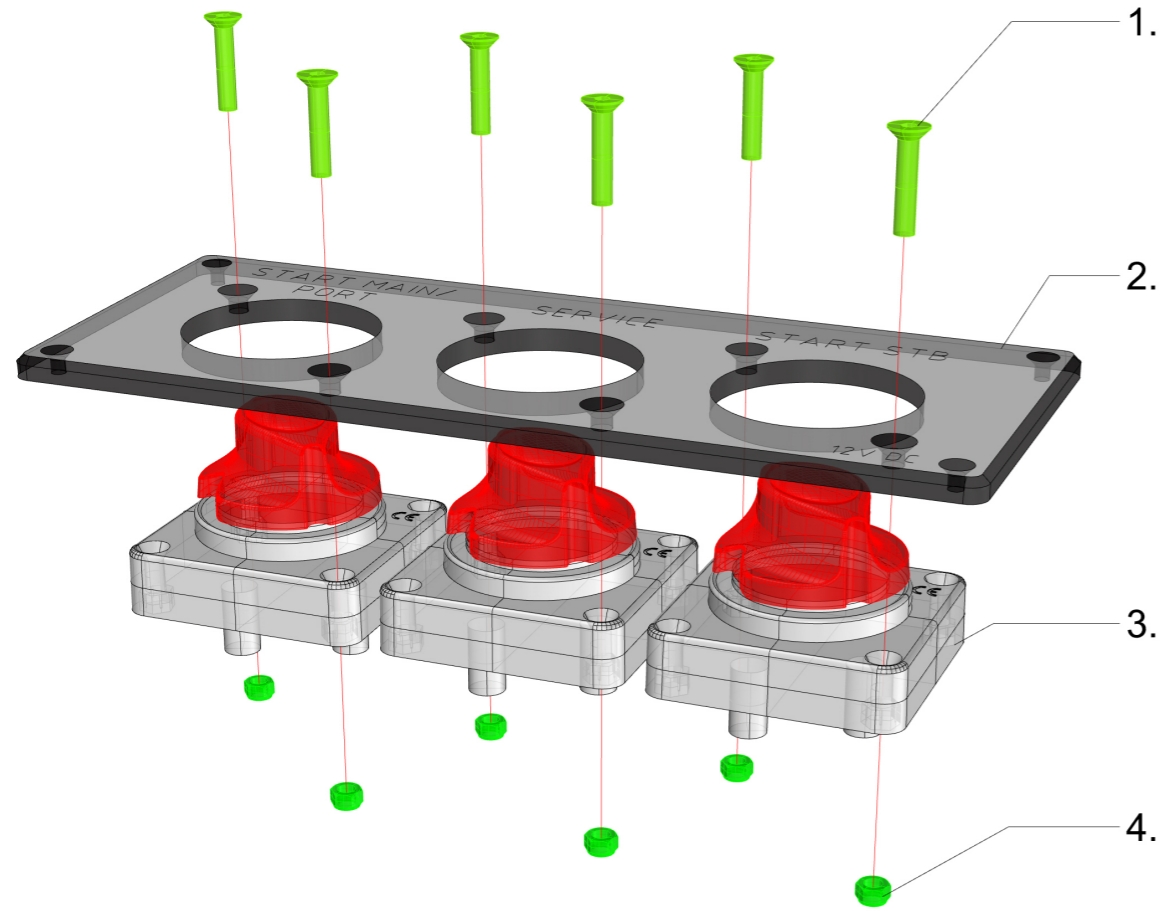

38683\_AXOPAR\_28\_MAIN\_SWITCH\_UNIT\_MANUAL DUAL ENG.

- 1. 6pcs VMI31807 - Countersunk head Screw HEX socket M5X25 DIN7991
- 2. 1pc 39053\_AXOPAR\_28\_MSU\_PANEL
- 3. 3pcs 701-PM - Battery Main Switch 275A, Panel Mounted - Bep 701B-PM
- 4. 6pcs VMI31539 - Self-locking HEX Nut M5 DIN985

16.05.-22 / TE

			Date	23.3.2023	Axopar		38683		2004468	
			Drawing by	PF	Boat		Sub-product code		Product code	
			Sheet rev.	1	28 MK3		MAIN SWITCH UNIT		Project ID	
Date of modification	Modified by	Description	Project rev.	A	Boat model		MANUAL		45 /	
1		2	4		5	6	7	8	Sheet	

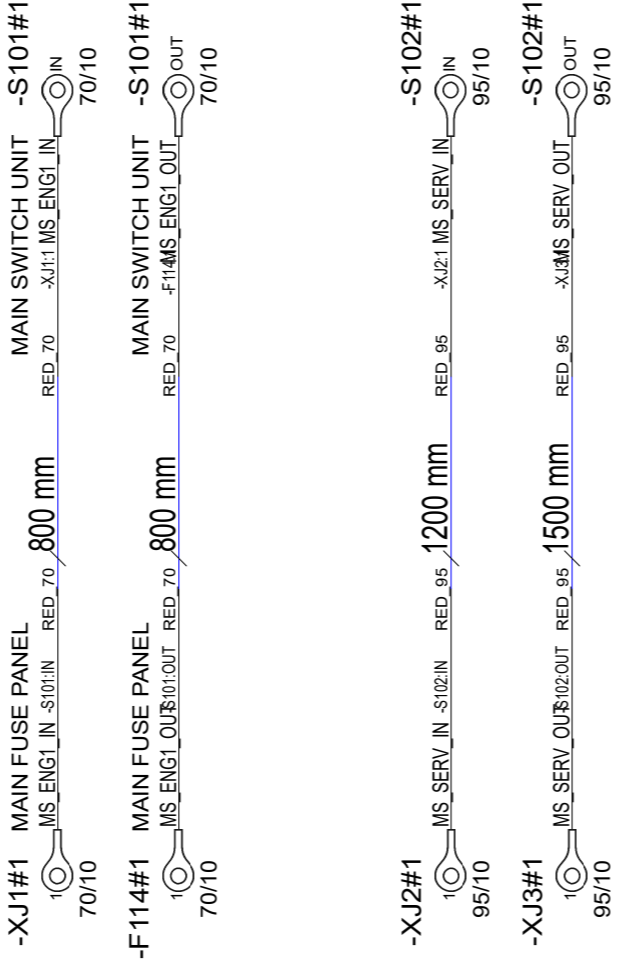
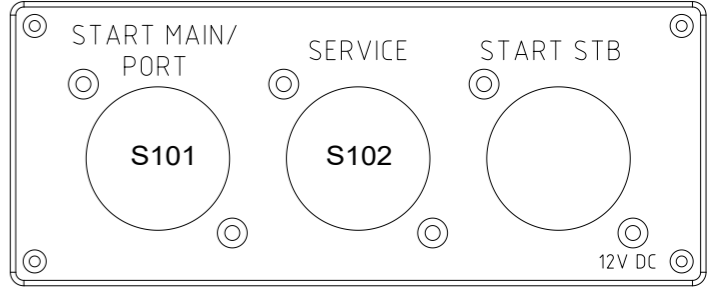
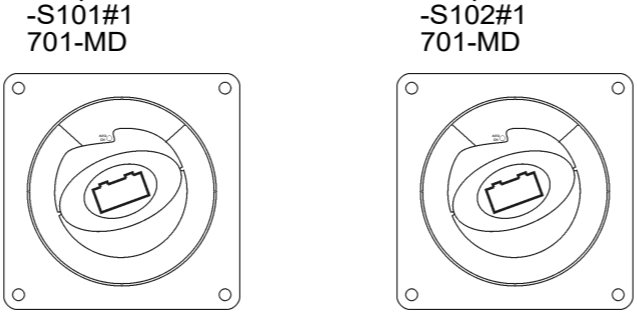
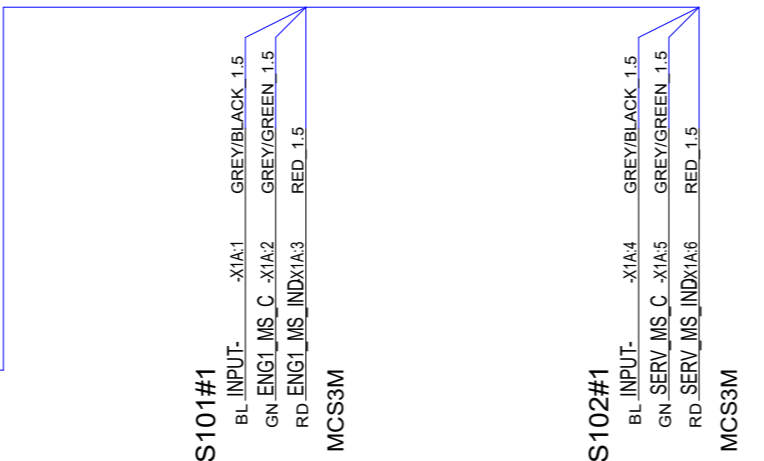
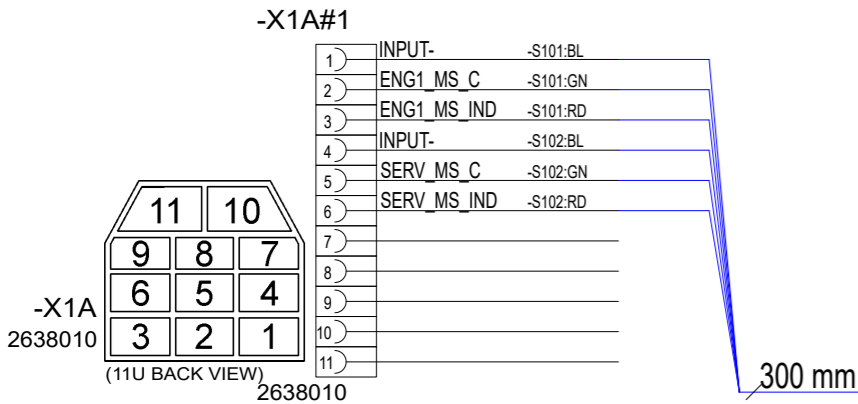

			Date	25.4.2023	Axopar		38909		2004468		
			Drawing by	PF	Boat		Sub-product code		Product code		
			Sheet rev.	1	28 MK3		MAIN SWITCH UNIT		HL		
Date of modification	Modified by	Description	Project rev.	A	Copyright by	Boat model		REMOTE SE		Loc	
1			4		5	6	7	8	46 / Sheet		

38909\_AXOPAR\_28\_MAIN\_SWITCH\_UNIT\_REMOTE\_SE

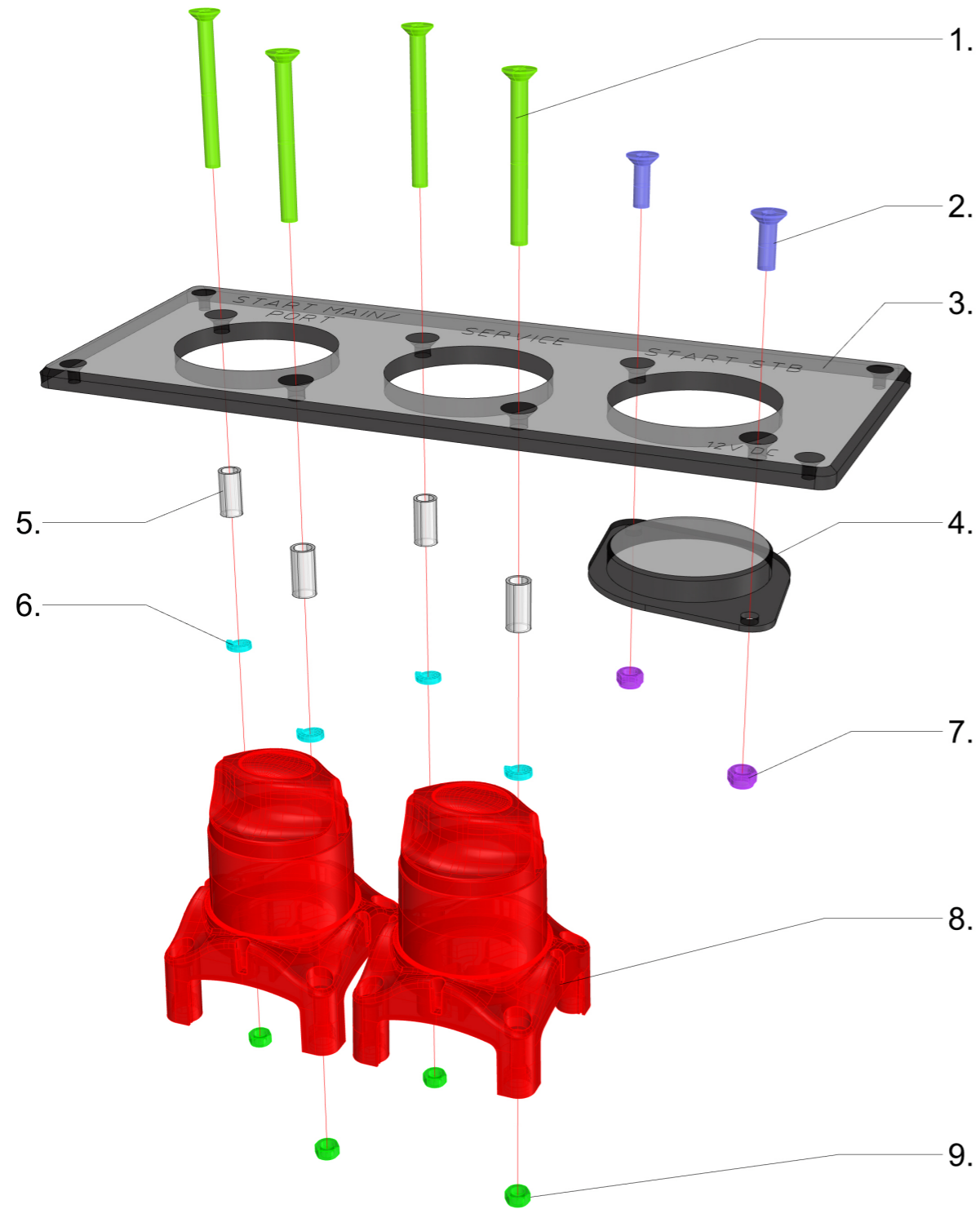

38909\_AXOPAR\_28\_MAIN\_SWITCH\_UNIT\_REMOTE\_SE

- 1. 4pcs VMI31811 - Countersunk head Screw HEX socket M5X50 DIN7991
- 3. 2pc VMI31796 - Countersunk head Screw HEX socket M5X16 DIN7991
- 3. 1pc 39053\_AXOPAR\_28\_MSU\_PANEL
- 4. 1pc 39054\_NAVIX\_MS\_PLUG\_BEP\_HPL
- 5. 4pcs 6440 - HOLKKI NAVIX PÄÄKYTKIMEEN - halk. 8/6mm pituus 16mm
- 6. 4pcs VMI31540 - Spring Lock Washer M5 DIN127
- 7. 2pcs VMI31539 - Self-locking HEX Nut M5 DIN985
- 8. 2pcs 14002110K Remote Controlled Battery Switch
- 9. 4pcs VMI31538 - HEX Nut M5 DIN934

16.05.-22 / TE

			Date	25.4.2023	Axopar		38909		2004468
			Drawing by	PF	Boat		Sub-product code		Project ID
			Sheet rev.	1	28 MK3		MAIN SWITCH UNIT		HL
Date of modification	Modified by	Description	Project rev.	A	Boat model		REMOTE SE		Loc
1		2	4		5	6	7	8	47 / Sheet



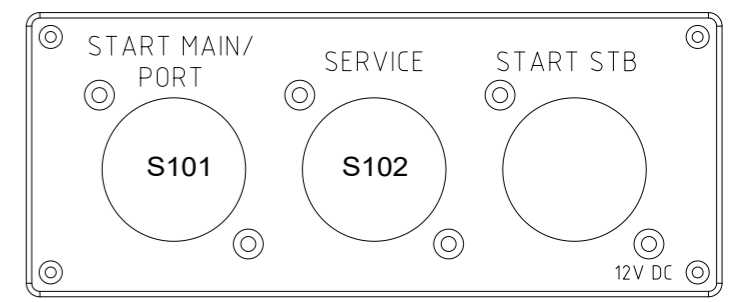
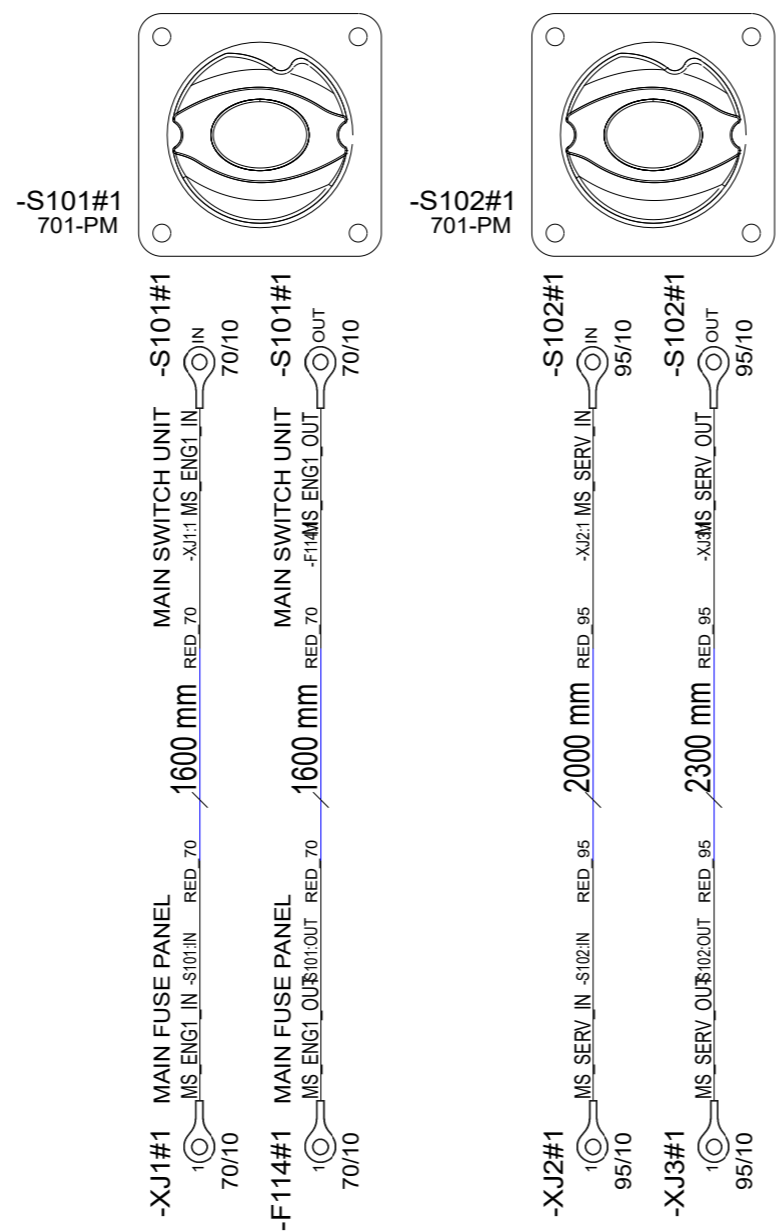

			Date	25.4.2023	Axopar		38910		2004468	
			Drawing by	PF	Boat		Sub-product code		Project ID	
			Sheet rev.	1	28 MK3		MAIN SWITCH UNIT		HL	
Date of modification	Modified by	Description	Project rev.	A	Copyright by	Boat model	MANUAL SE	Loc		48 / Sheet
1	2	3	4	5	6	7	8	8		

38910\_AXOPAR\_28\_MAIN\_SWITCH\_UNIT\_MANUAL\_SE

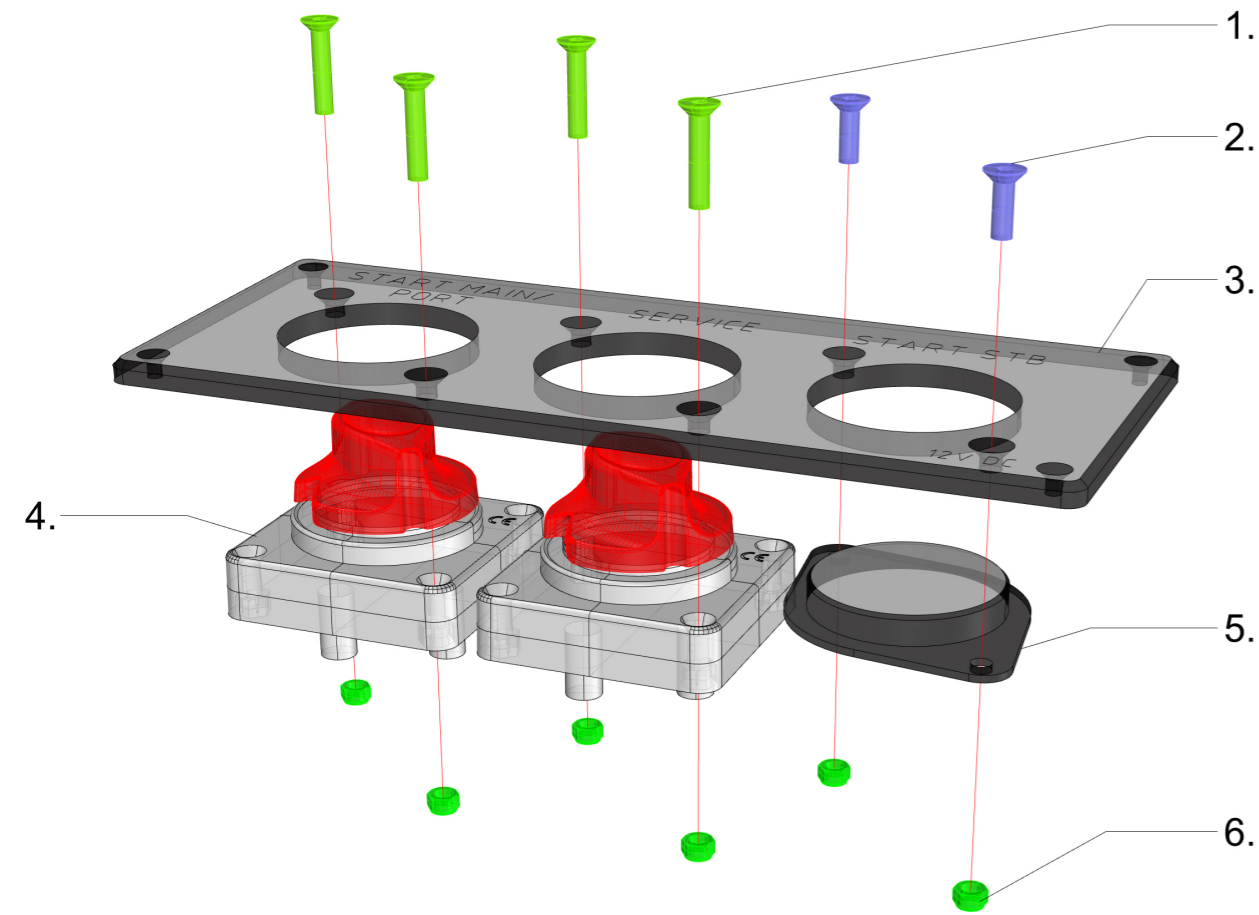

38910\_AXOPAR\_28\_MAIN\_SWITCH\_UNIT\_MANUAL\_SE

- 1. 4pcs VMI31807 - Countersunk head Screw HEX socket M5X25 DIN7991
- 2. 2pcs VMI31796 - Countersunk head Screw HEX socket M5X16 DIN7991
- 3. 1pc 39053\_AXOPAR\_28\_MSU\_PANEL
- 4. 2pcs 701-PM - Battery Main Switch 275A, Panel Mounted - Bep 701B-PM
- 5. 1pc 39054\_NAVIX\_MS\_PLUG\_BEP\_HPL
- 6. 6pcs VMI31539 - Self-locking HEX Nut M5 DIN985

16.05.-22 / TE

			Date	25.4.2023	Axopar		38910		2004468	
			Drawing by	PF	Boat		Sub-product code		Project ID	
			Sheet rev.	1	28 MK3		MAIN SWITCH UNIT		HL	
Date of modification	Modified by	Description	Project rev.	A	Boat model		MANUAL SE		Loc	
1			4		5	6	7		8	49 / Sheet



Copyright by

# 38684\_AXOPAR\_28\_MAIN\_FUSE\_PANEL

- 1. 4pcs VMI31829 - HEX socket Head Cap Screw M6X20 DIN912  
BACKSIDE OF 39046
- 4pcs VMI31826 - Self-locking HEX Nut M6 DIN985

- 2. 1pc 39055\_AXOPAR\_28\_BOX\_SUPPORT\_V1  
ZIPTIES

- 3. 1pc 39058\_NAVIX\_LINE\_BUS\_BAR\_TYPE5C\_6X  
1pc VMI32012 HEX NUT M8 DIN934  
1pc VMI32013 FLAT WASHER FOR HEX BOLT  
1pc VMI32011 SPRING LOCK WASHER M8 DIN127  
1pc VMI32018 HEX BOLT FULL THREAD M8X25 DIN933

- 4. 1pc 39057\_NAVIX\_LINE\_BUS\_BAR\_TYPE5C\_3X  
1pc VMI32012 HEX NUT M8 DIN934  
1pc VMI32013 FLAT WASHER FOR HEX BOLT  
1pc VMI32011 SPRING LOCK WASHER M8 DIN127  
1pc VMI32018 HEX BOLT FULL THREAD M8X25 DIN933

- 5. 7pcs 90001\_NAVIX\_LINE\_ANL HOLDER\_TYPE5

- 6. 1pc 39046\_AXOPAR\_28\_MAIN\_FUSE\_PANEL\_PLATE

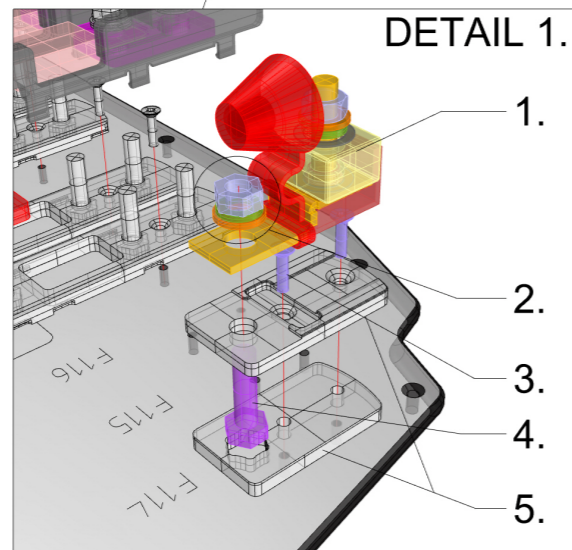
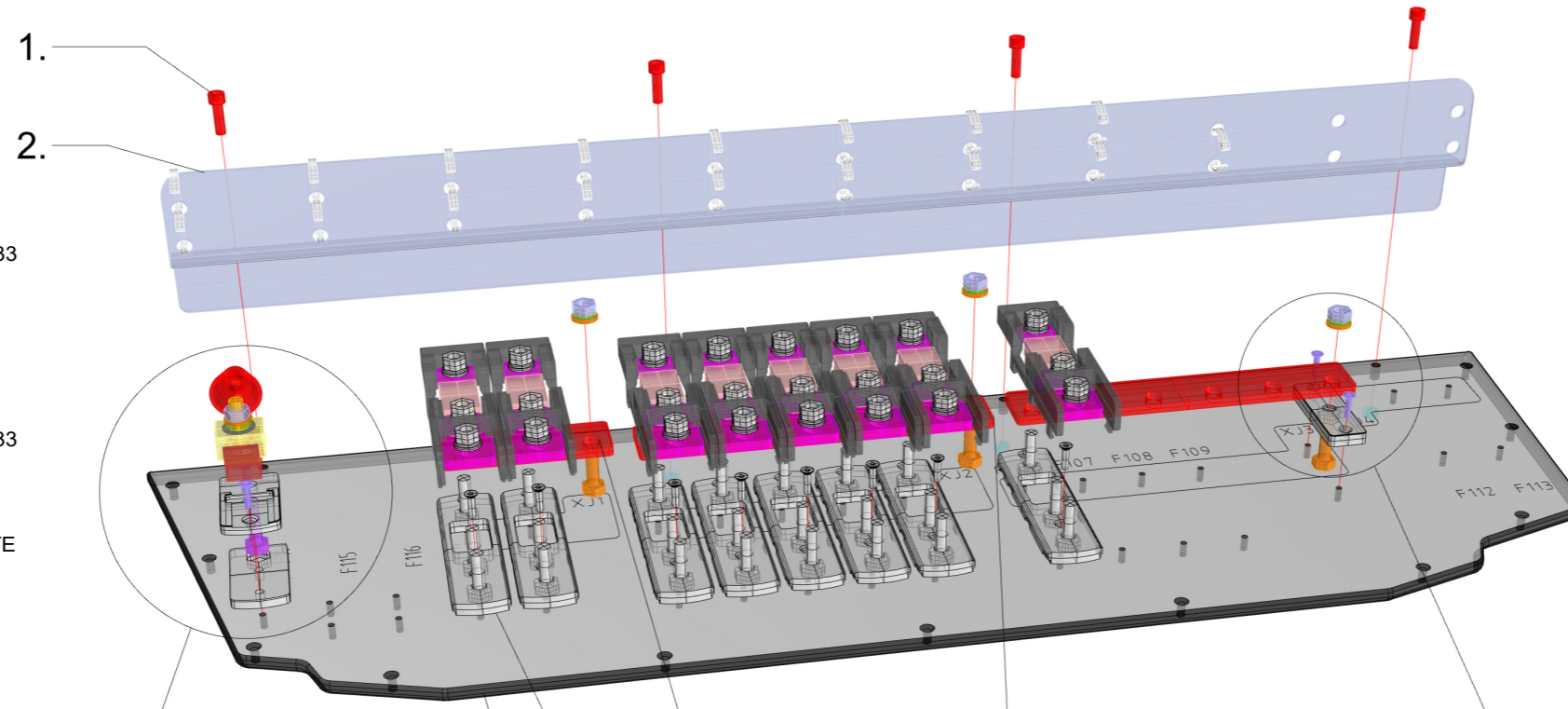

DETAIL 1.

- 1. 1pc 34642 CFBAR1-250SP SINGLE STUD  
  
1pc VMI32012 HEX NUT M8 DIN934  
1pc VMI32013 FLAT WASHER FOR HEX BOLT  
1pc VMI32011 SPRING LOCK WASHER M8 DIN127  
1pc 34641 -B.6 CFCOVER-1R SINGLE STUD/RED  
1pc 34640 -PS\_F.6 CUBE FUSE MRFB-080 80A
- 2. 1pc VMI32012 HEX NUT M8 DIN934  
1pc VMI32013 FLAT WASHER FOR HEX BOLT  
1pc VMI32011 SPRING LOCK WASHER M8 DIN127
- 3. 3pcs VMI30917 COUNTERSUNK HEAD SCREW HEX SOCKET  
M4X16 DIN7991
- 4. 1pc VMI32019 - HEX Bolt Full thread M8X30 DIN933
- 5. 1pc 39047\_NAVIX\_LINE\_CUBE\_FUSE\_HOLDER\_SINGLE

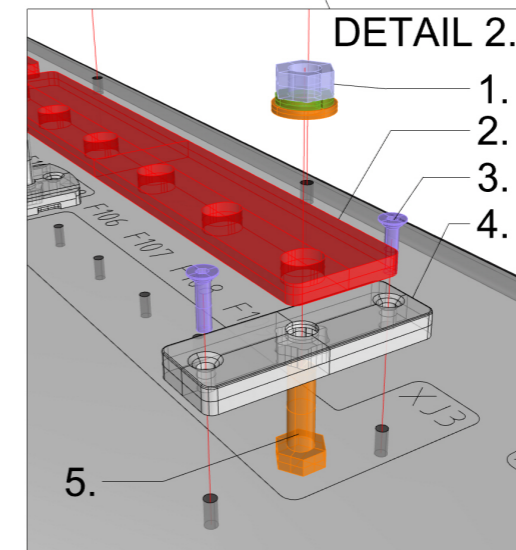

DETAIL 2.

DETAIL 2.

- 1. 1pc VMI32012 HEX NUT M8 DIN934  
1pc VMI32013 FLAT WASHER FOR HEX BOLT  
1pc VMI32011 SPRING LOCK WASHER M8 DIN127
- 2. 1pc 39058\_NAVIX\_LINE\_BUS\_BAR\_TYPE5C\_6X
- 3. 2pcs VMI30917 COUNTERSUNK HEAD SCREW HEX SOCKET M4X16 DIN7991
- 4. 1pc 39048\_NAVIX\_LINE\_BOLT\_BASE\_1
- 5. 1pc VMI32018 HEX BOLT FULL THREAD M8X25 DIN933

16.05.-23 / TE

			Date	3.4.2023		Axopar		38684		2004468		
			Drawing by	PF		Boat	28 MK3		Sub-product code		Project ID	
			Sheet rev.	1		MAIN FUSE PANEL		HL		50 / Sheet		
Date of modification	Modified by	Description	Project rev.	A		Title		Loc				



INSTALL FUSES IN PANEL

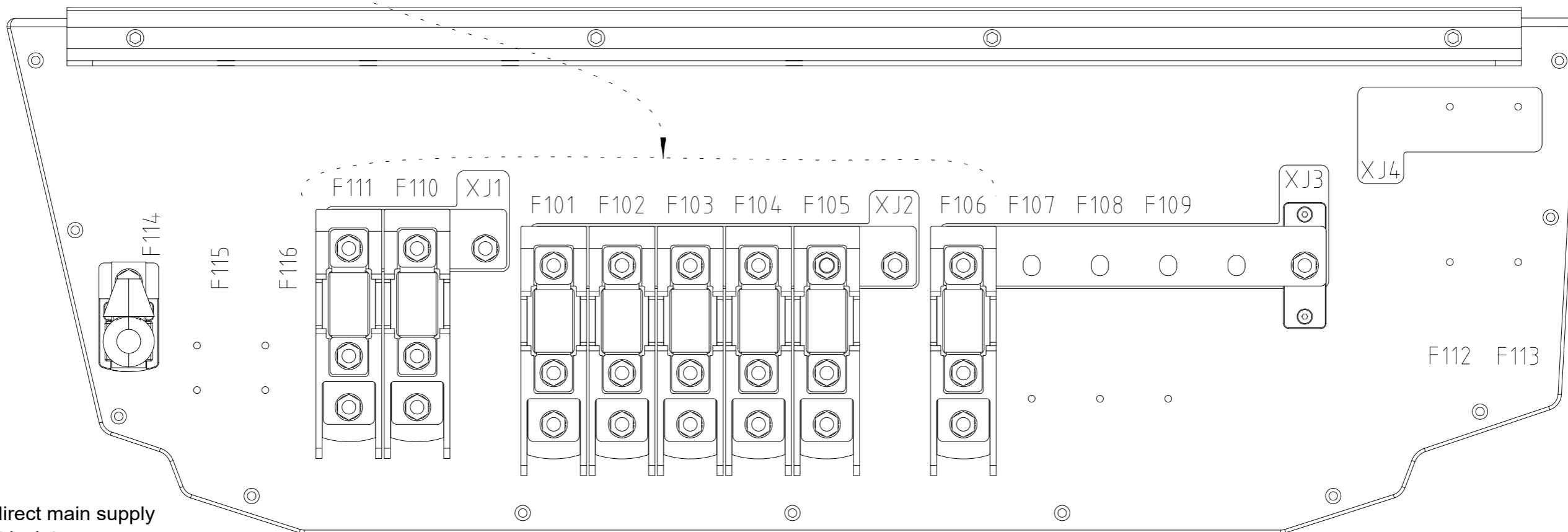
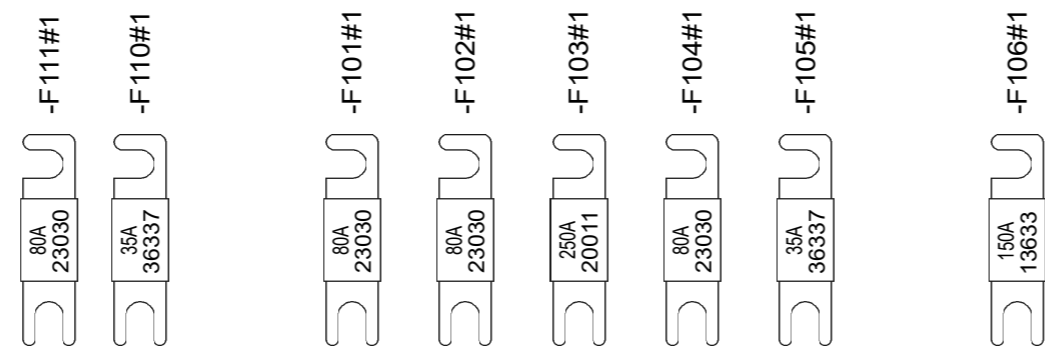

FUSE FUNCTION

- F101 To console, direct main supply
- F102 From Q1 port isolator
- F103 From service battery/-ies
- F104 From Q2 stb isolator
- F105 From battery charger
- F106 To console, switched main supply
- F107 OPT aft winch
- F108 OPT gyro
- F109 OPT amplifier
- F110 From battery charger
- F111 From Q1 port isolator
- F112 OPT From Q2 stb isolator
- F113 OPT From battery charger
- F114 OPT APS or POWER STEERING PUMP
- F115 OPT APS or POWER STEERING PUMP
- F116 OPT APS

			Date	23.3.2023	Axopar		38684		2004468	
			Drawing by	PF	Boat		Sub-product code		Product code	
			Sheet rev.	1	28 MK3		MAIN FUSE PANEL		Project ID	
Date of modification	Modified by	Description	Project rev.	A	Copyright by	Boat model	Title	HL	51/	
1			4		5	6	7	Loc	Sheet	

**FRONT VIEW**

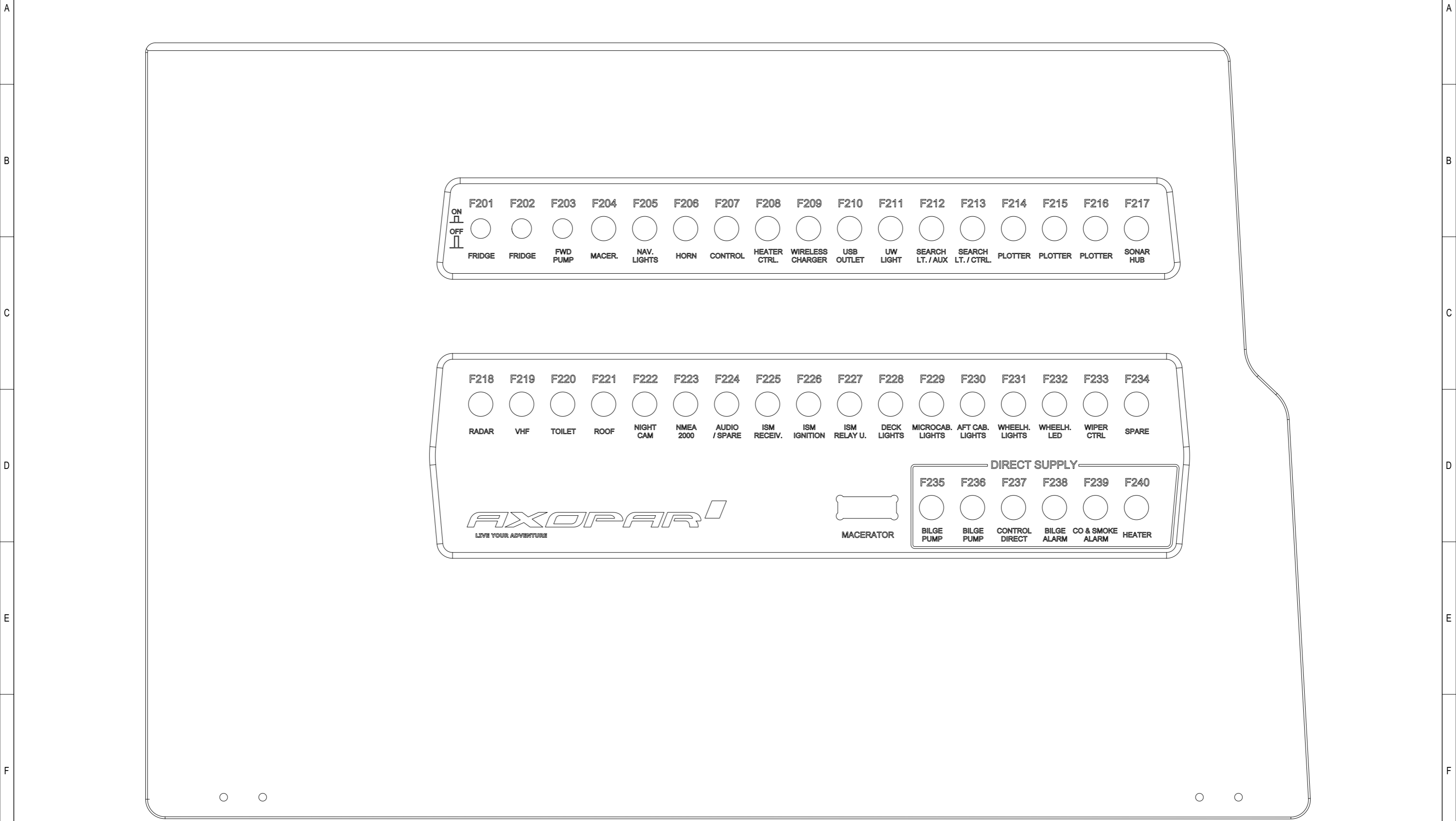

			Date	4.4.2023	Axopar		38685		2004468	
			Drawing by	PF	Boat		Sub-product code		Project ID	
			Sheet rev.	1	28 MK3		FUSE UNIT		HL	
Date of modification	Modified by	Description	Project rev.	A	Copyright by	Boat model	Title	Loc	52 / Sheet	
1	2	3	4	5	6	7	8	8		

# 38685\_AXOPAR\_28\_FUSE\_UNIT

38685\_AXOPAR\_28\_FUSE\_UNIT

- 1. 1 PC 39169\_AXOPAR\_28\_MICROCAB\_AFT\_WALL\_PANEL\_LOW\_PORT
  - 2. 1 PC 28042 - Busbar 10 Gang 150A - Blue Sea 2301
  - 3. 2 PCS VMI30944 - HEX socket Head Cap Screw M4X12 DIN912
  - 4. 1 PC C1501ABBB - KYTKIN 0-1 MOM MUSTA/PUN, MATTA - Arcoelectric C1501ABBB
  - 5. 1 PC 39170\_AXOPAR\_28\_FUSE\_PANEL\_(WOC)  
36 PCS CARLING CMB SERIES (AS IN DIAGRAM)  
1 PC CARLING CLB SERIES (AS IN DIAGRAM)  
3 PCS DD FUSE (AS IN DIAGRAM)
  - 6. 8 PCS VMI30943 - HEX socket Head Cap Screw M4X10 DIN912
  - 7. 4 PCS VMI36559 - Self Adhesive Black Cable Tie Mount 5,3mm  
4 PCS VMI30913 - Countersunk head Screw HEX socket M4X8 DIN7991  
4 PCS ZIP TIES
  - 8. 5 PCS RELE (AS IN DIAGRAM)
  - 9. 5 PCS VMI30904 SPRING LOCK WASHER M4 DIN127  
5 PCS VMI30905 HEX NUT M4 DIN934
  - 10. 1 PC 36213 - Insulated Stud, Red - Bep IS-10MM-1R  
2 PCS VMI32012 HEX NUT M8 DIN934  
1 PC VMI32011 SPRING LOCK WASHER M8 DIN127  
2 PCS VMI30944 - HEX socket Head Cap Screw M4X12 DIN912  
2 PCS VMI30906 - Flat Washer for HEX bolts and nuts M4 DIN125A
- 23.05.2023 / TE (2004468)

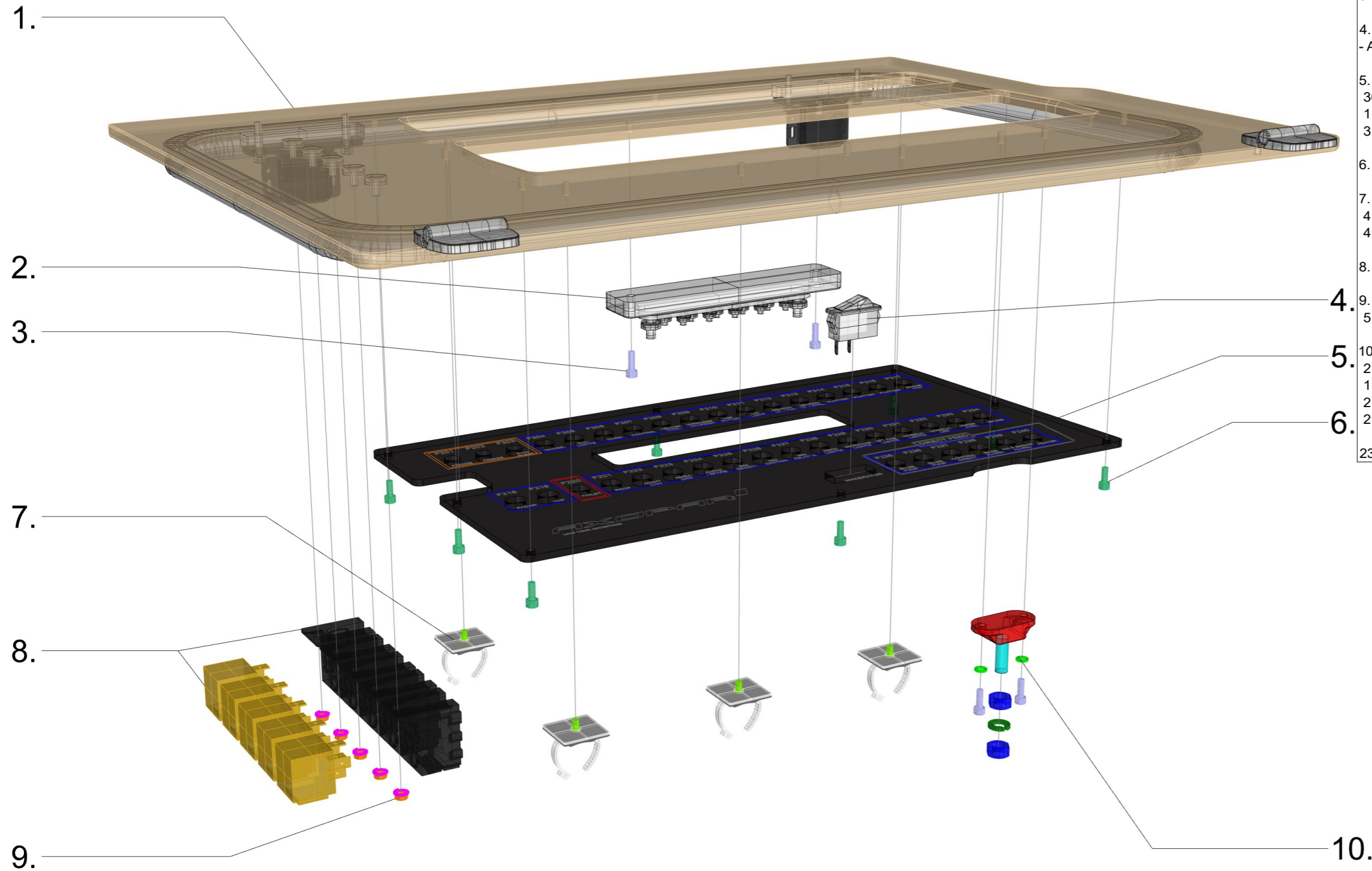

			Date	8.5.2023	Axopar		38685		2004468	
			Drawing by	PF	Boat		Sub-product code		Project ID	
			Sheet rev.	1	28 MK3		FUSE UNIT		HL	
Date of modification	Modified by	Description	Project rev.	A	Copyright by	Boat model	Title	Loc	53 / Sheet	
1		2	3	4	5	6	7		8	

# BACK VIEW

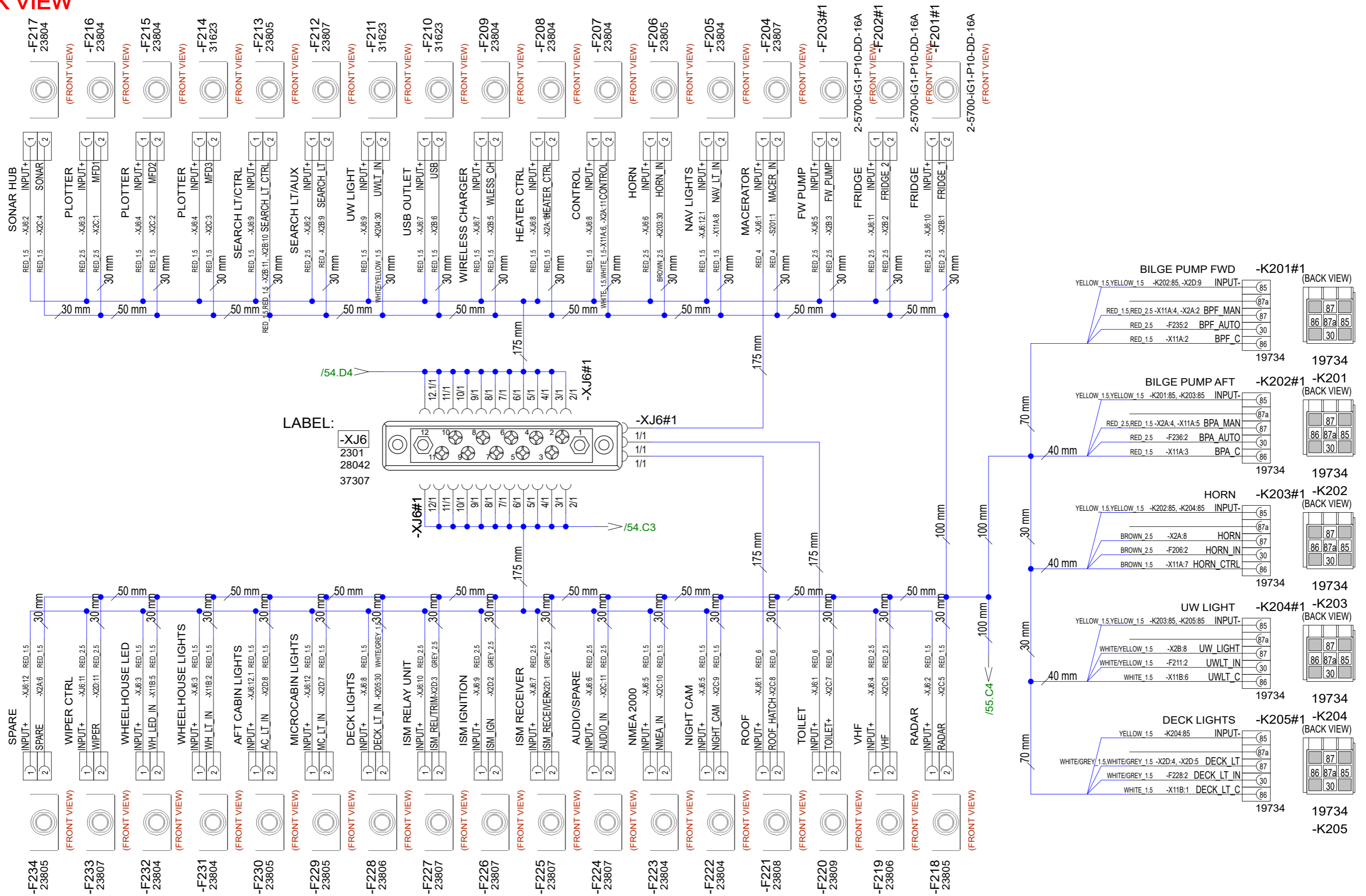

Date 24.3.2023  
 Drawing by PF  
 Sheet rev. 1  
 Project rev. A



Axopar  
 Boat 28 MK3  
 Boat model

Sub-product code	38685	Product code	2004468
Title	FUSE UNIT		Project ID
	HL		54 /
	Loc		Sheet

Date of modification	Modified by	Description

# BACK VIEW

(DIRECT)

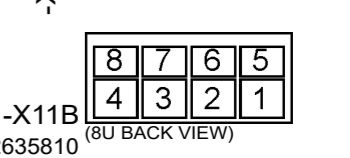
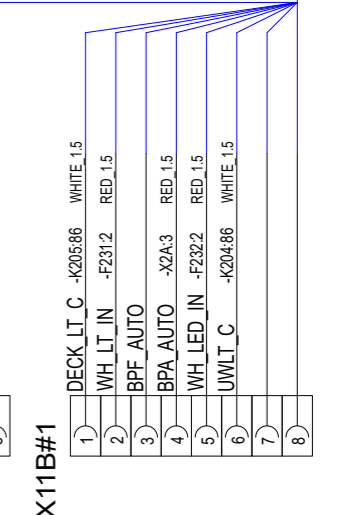
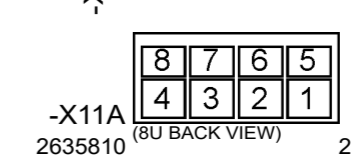
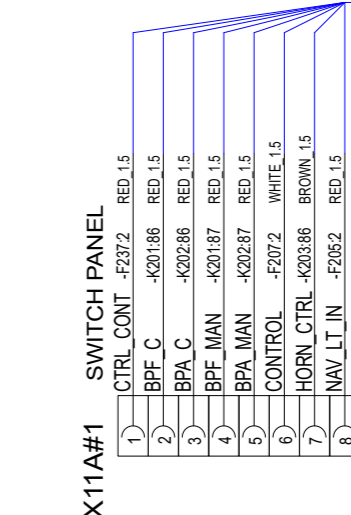
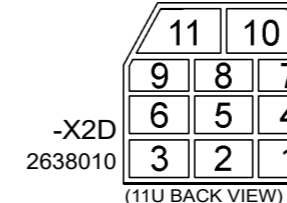
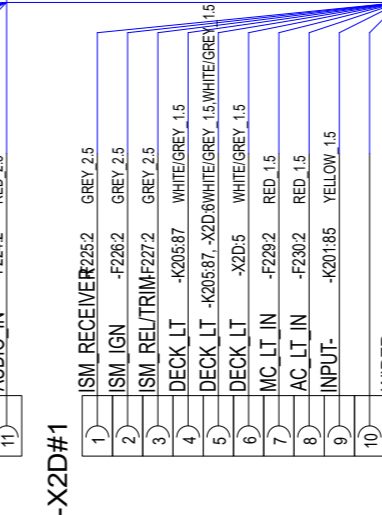
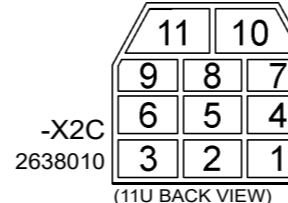
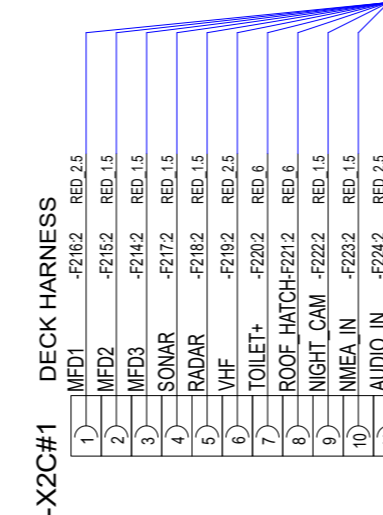
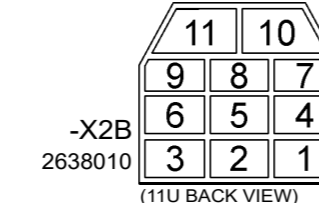
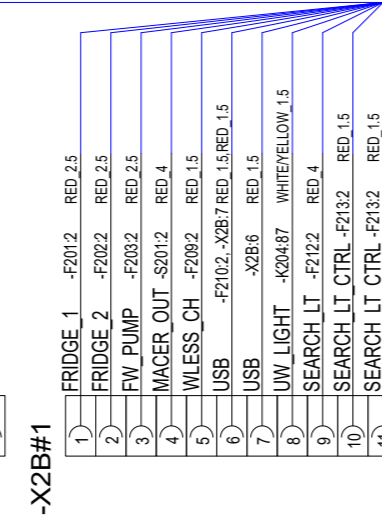
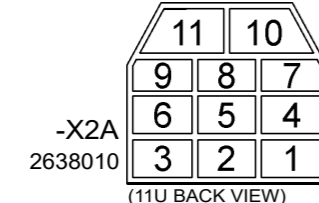
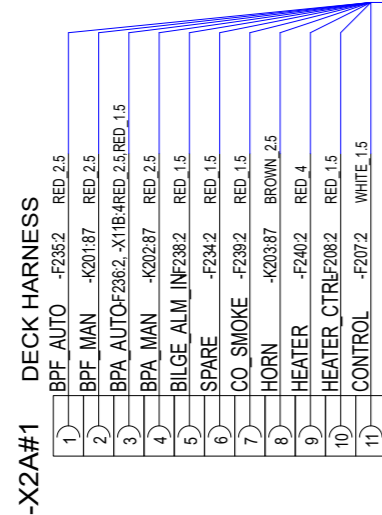
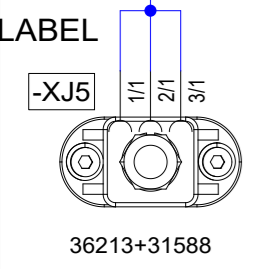
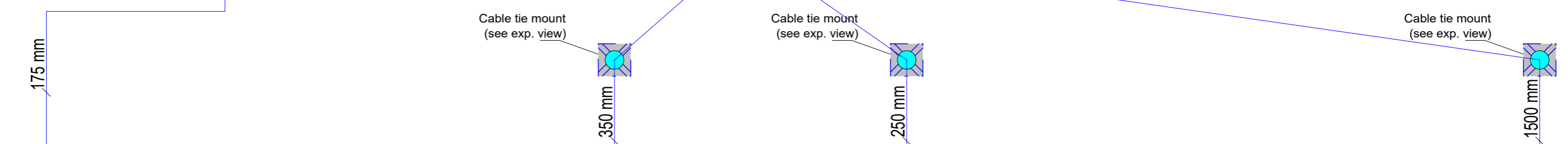
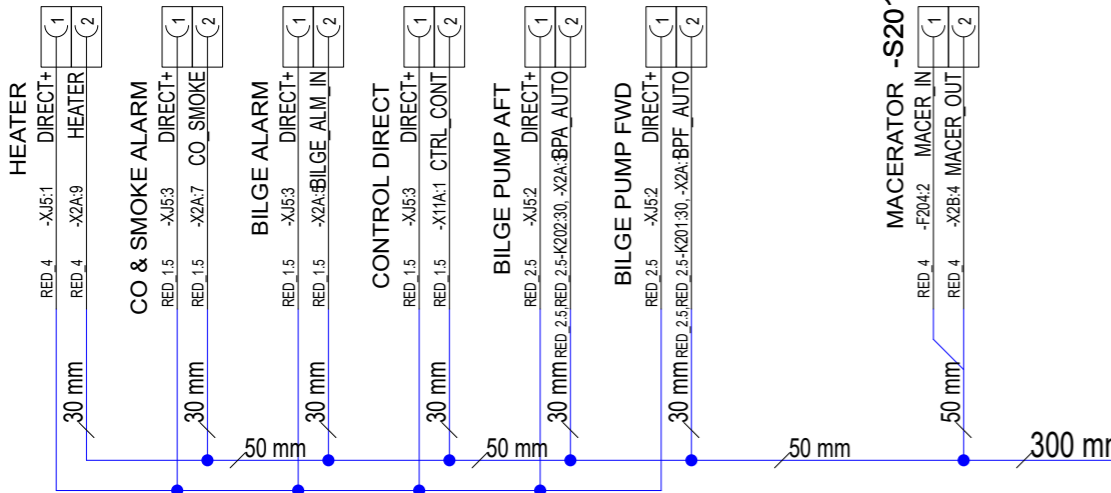
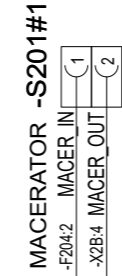
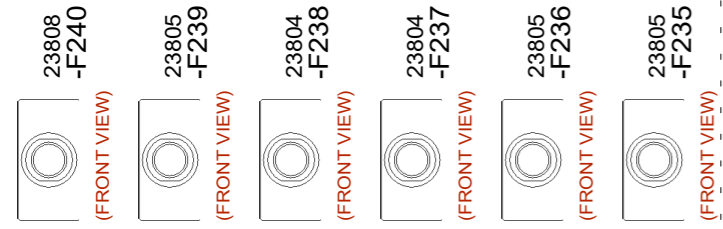

Date 17.4.2023			Axopar			38685		2004468		
Drawing by PF			Boat 28 MK3			Product code		Project ID		
Sheet rev. 1			Copyright by NAVIX			Title FUSE UNIT		HL		
Project rev. A			Boat model			Loc		55 / Sheet		
Date of modification	Modified by	Description	Date		Boat		Product code		Project ID	

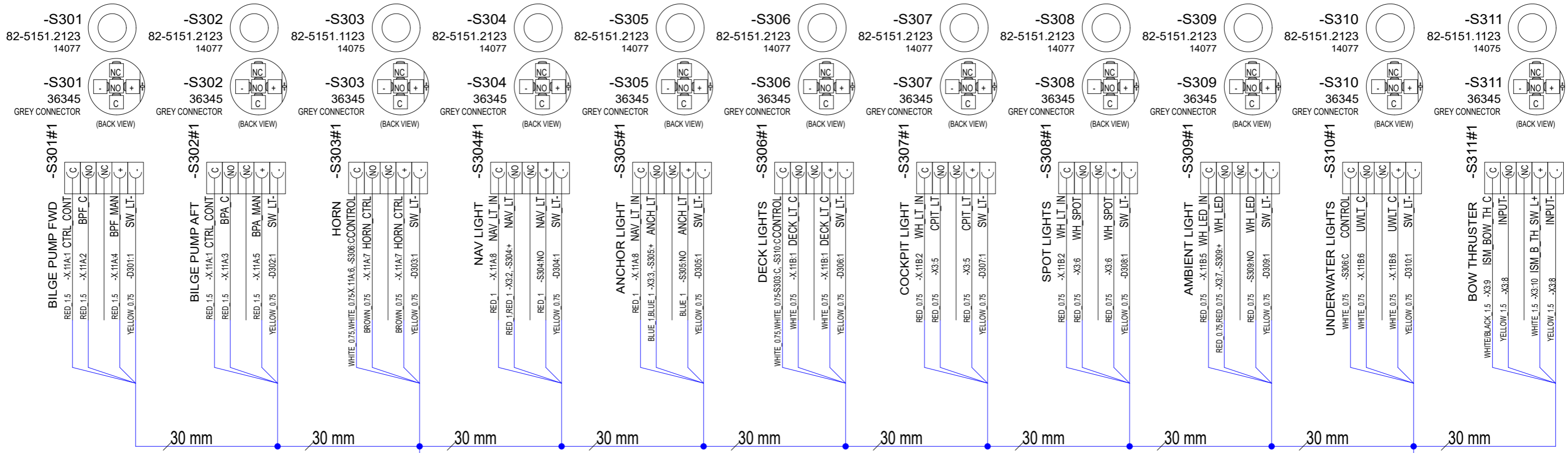

(XH20 CONNECTS TO "SWITCH PANEL EXTENDED")

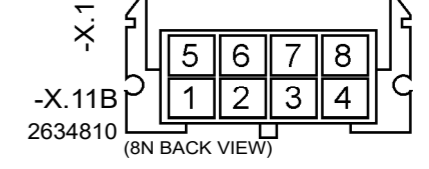
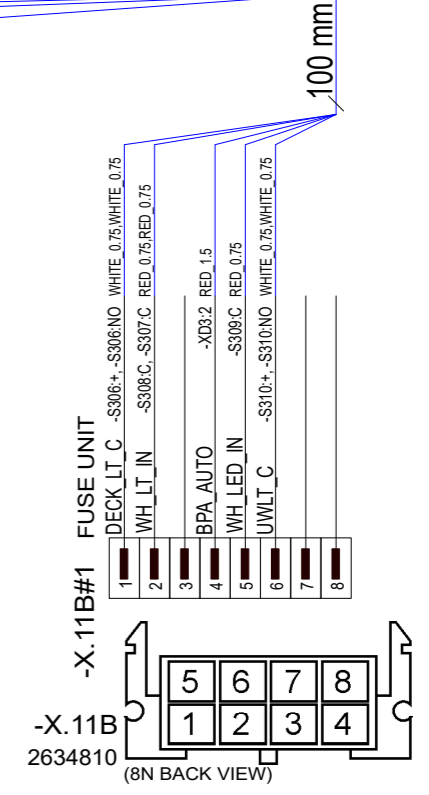
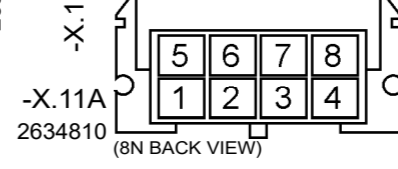
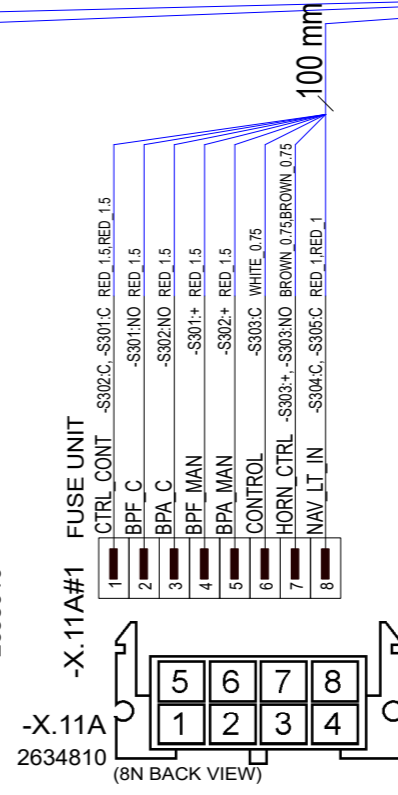
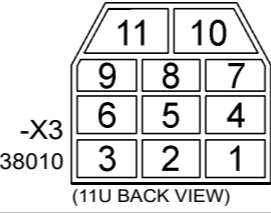
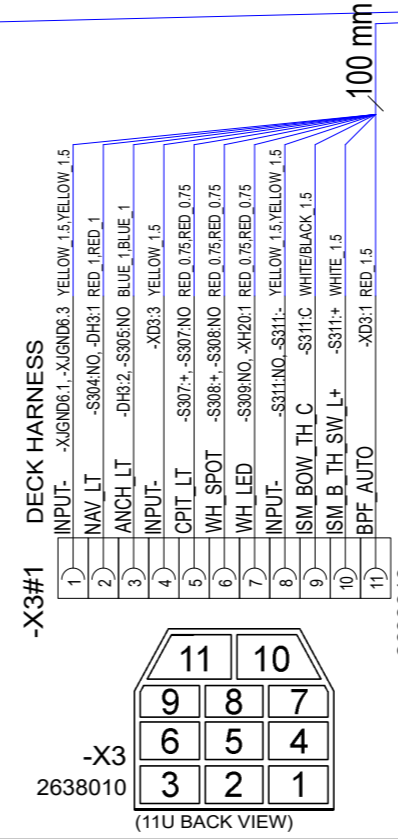
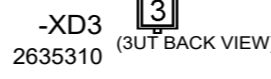
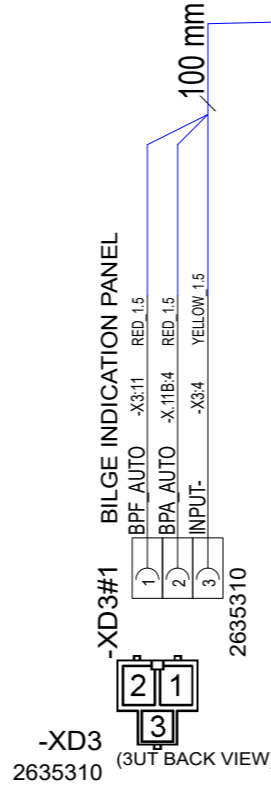
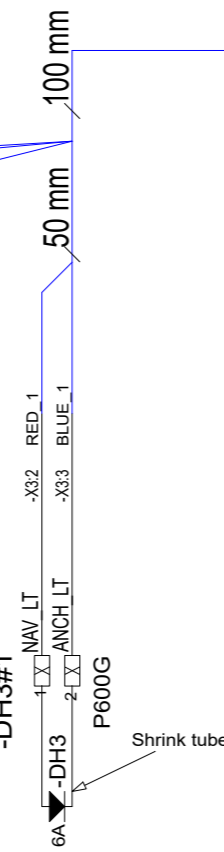
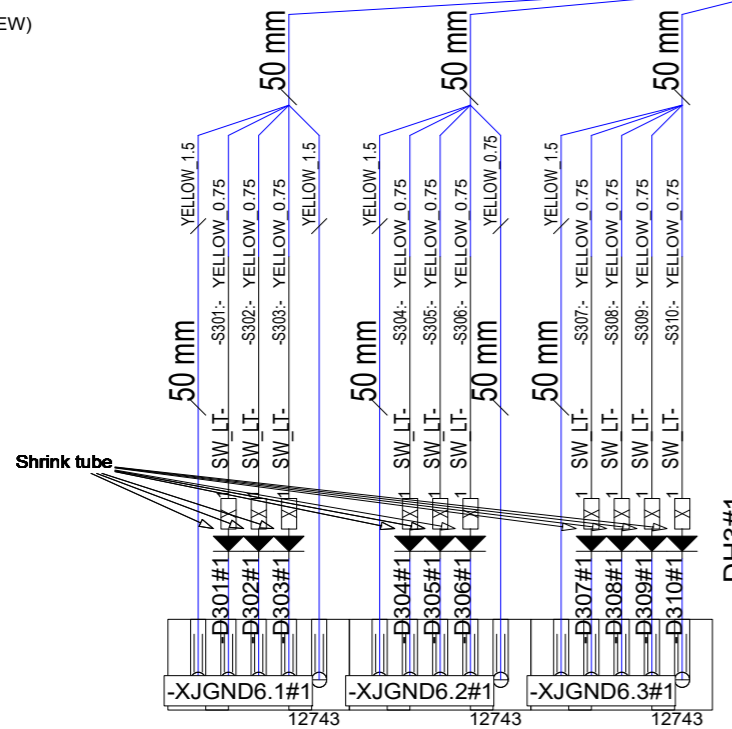
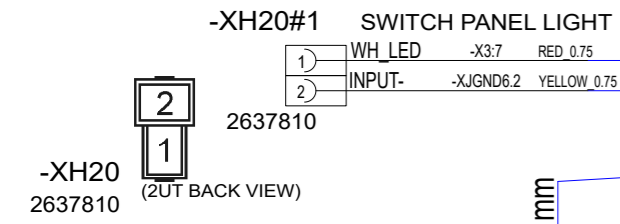

Date of modification	Modified by	Description
1		
2		
3		
4		

Date	23.3.2023
Drawing by	PF
Sheet rev.	1
Project rev.	A



Copyright by

Axopar
Boat
28 MK3
Boat model

Sub-product code	38686
Title	SWITCH PANEL

Product code	2004468
Project ID	56 /
HL	Sheet
Loc	

# 38686\_AXOPAR\_28\_SWITCH\_PANEL

38686\_AXOPAR\_28\_SWITCH\_PANEL

- 1. 11PCS HALO SWITCH (AS IN DIAGRAM)
- 2. 1PC 39239\_AXOPAR\_28\_SWITCH\_PANEL\_INSERT\_PORT
- 3. 1PC 39271\_AXOPAR\_28\_SWITCH\_PANEL\_BASE
- 4. 11PCS HALO SWITCH NUT

01.06.2023 / TE (2004468)

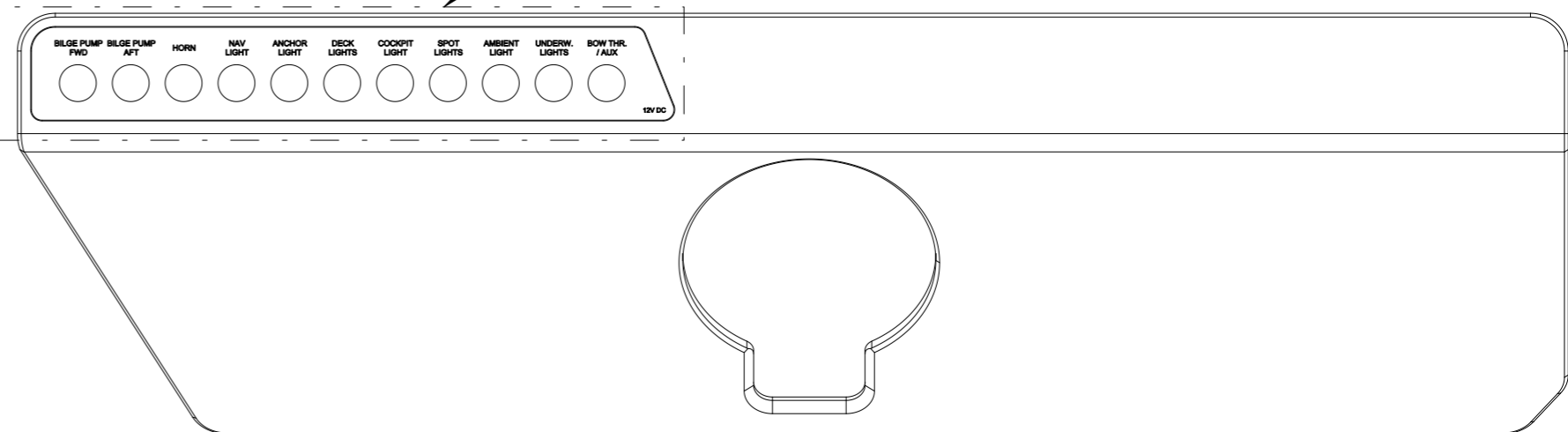
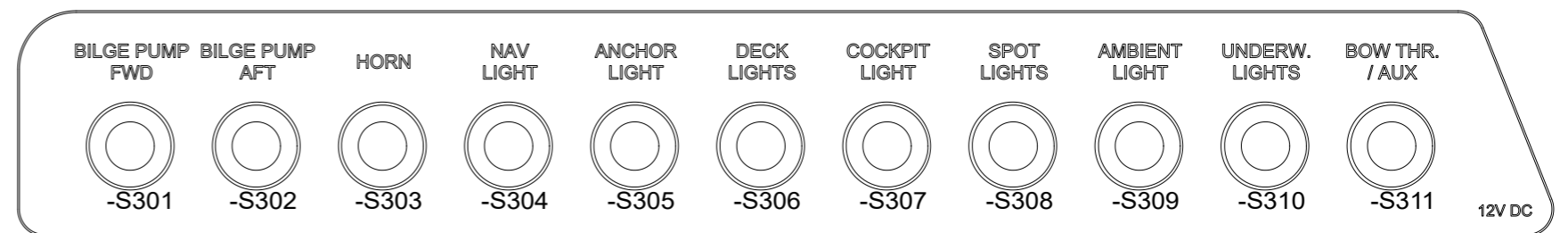
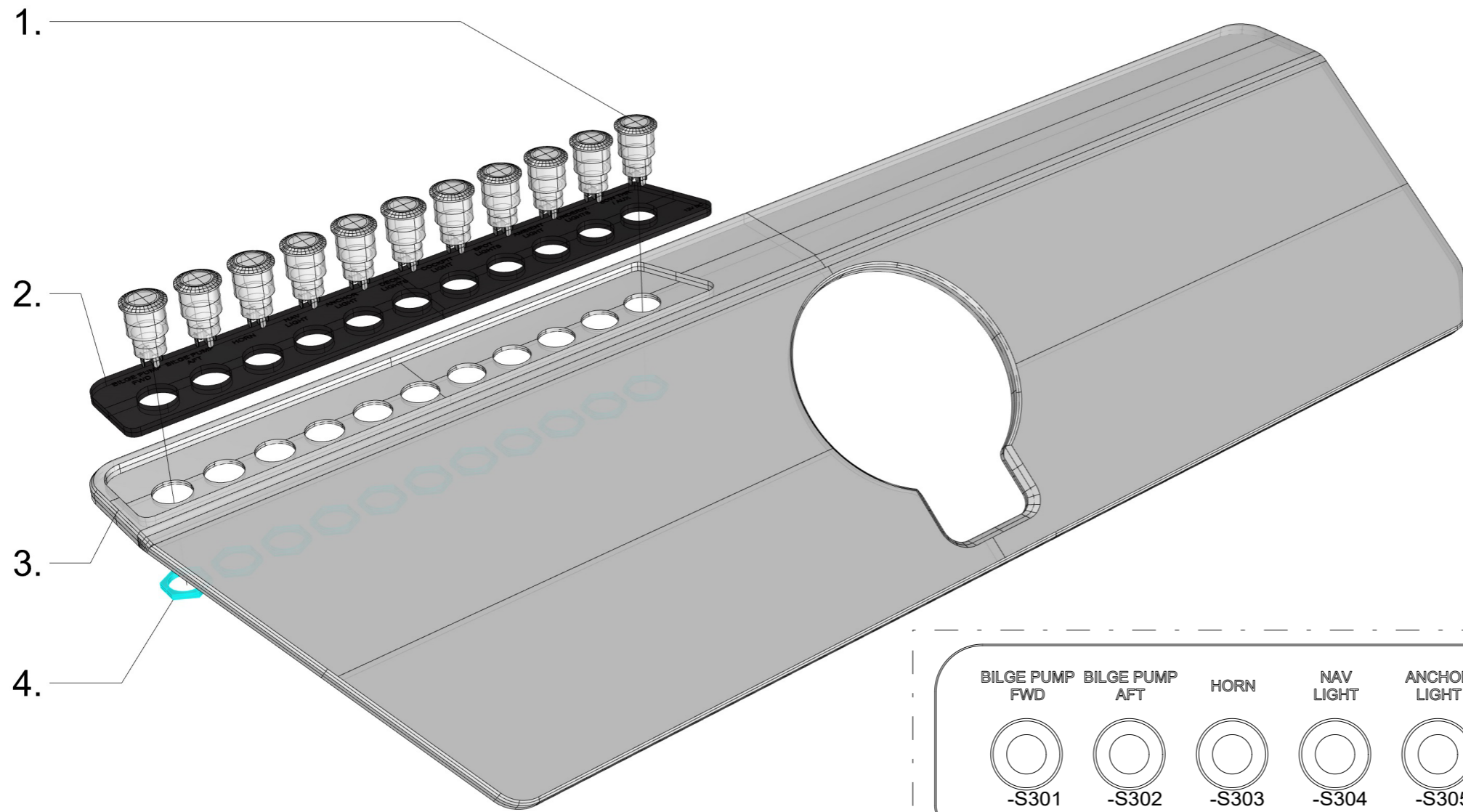

			Date	19.4.2023	Axopar		38686		2004468	
			Drawing by	PF	Boat		Product code		Project ID	
			Sheet rev.	1	28 MK3		SWITCH PANEL		HL	
Date of modification	Modified by	Description	Project rev.	A	Copyright by	Boat model	Title	Loc	57 / Sheet	
1	2	3	4	5	6	7	8			

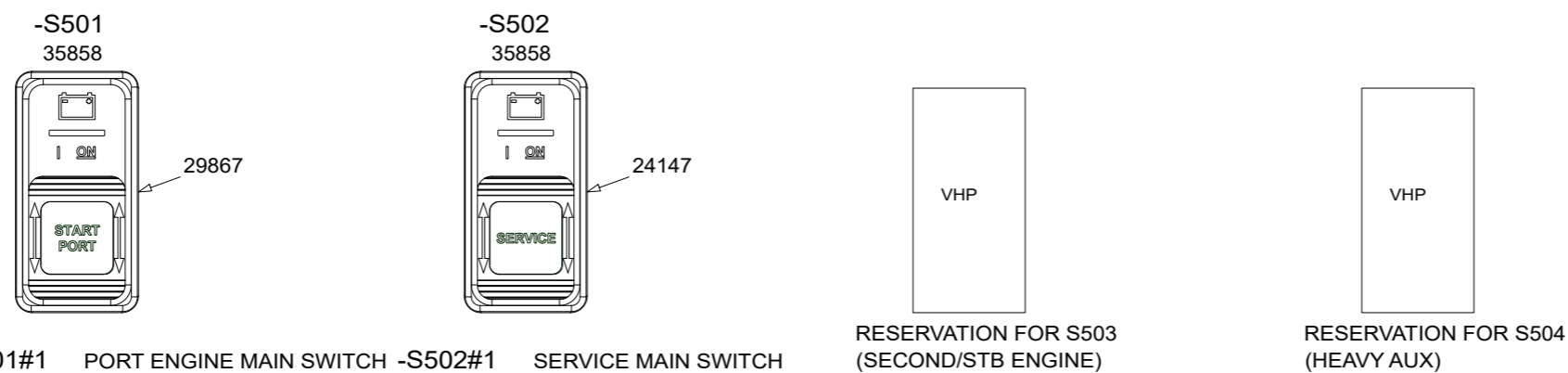
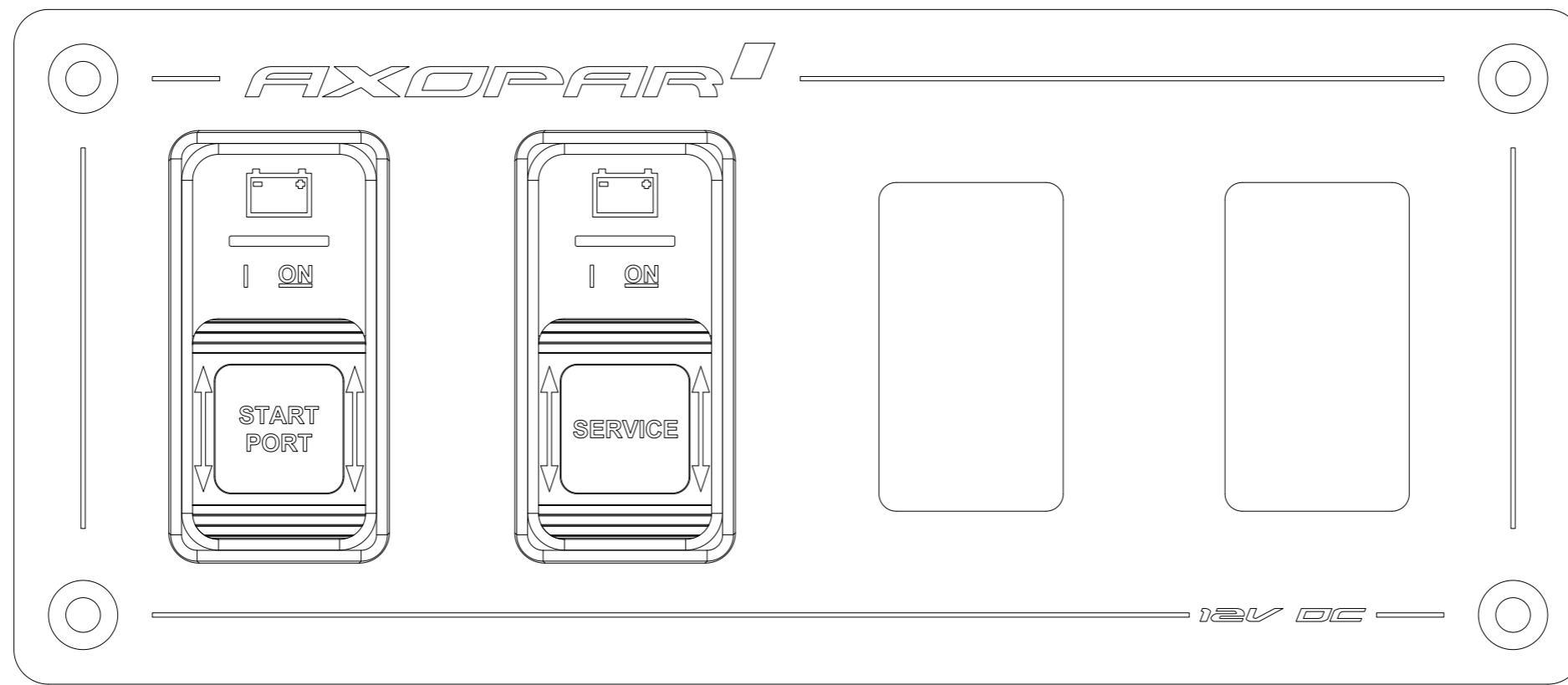

-S501#1 PORT ENGINE MAIN SWITCH -S502#1 SERVICE MAIN SWITCH

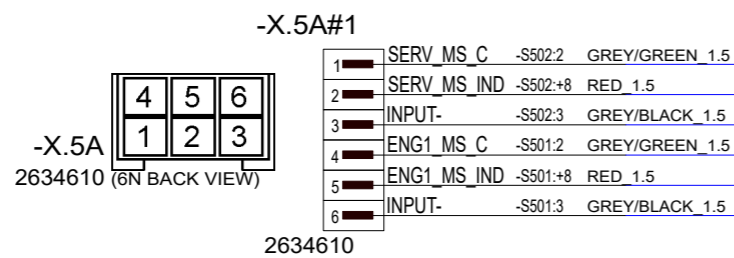
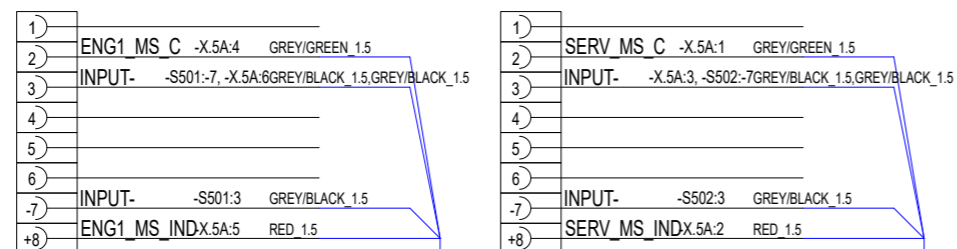

			Date	27.3.2023	Axopar		38687		2004468	
			Drawing by	PF	Boat		Product code		Project ID	
			Sheet rev.	1	28 MK3		MAIN SWITCH		HL	
Date of modification			Modified by		Boat model		CONTROL PANEL		Loc	
1	2	3	4	5	6	7	8	58 /		Sheet







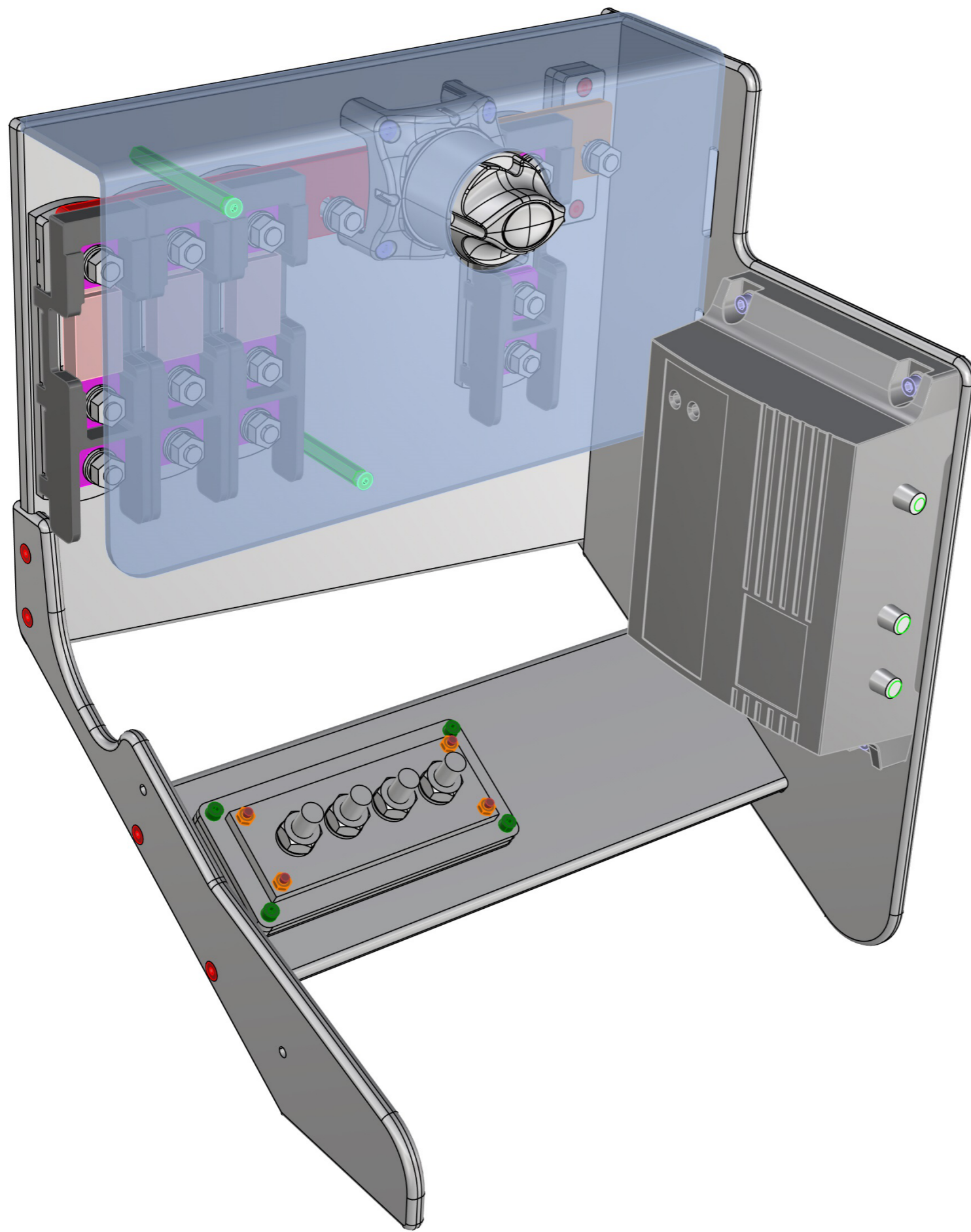

INCLUDED. CUSTOMER INSTALLS TO  
38687 MAIN SWITCH CONTROL PANEL

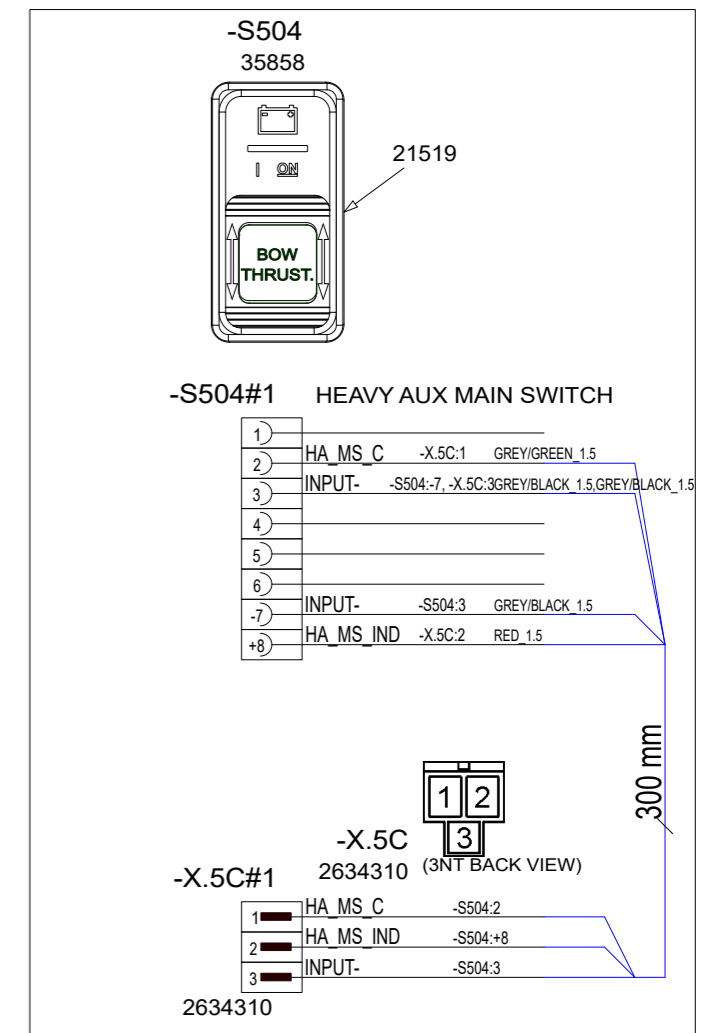

			Date	27.3.2023	Axopar		38688		2004468	
			Drawing by	PF	Boat		Product code		Project ID	
			Sheet rev.	1	28 MK3		BOW THRUSTER UNIT		HL	
Date of modification	Modified by	Description	Project rev.	A	Copyright by	Boat model	Title	Loc	60 / Sheet	
1			4		5	6	7		8	

# PLACEMENT OF ELECTRICAL COMPONENTS

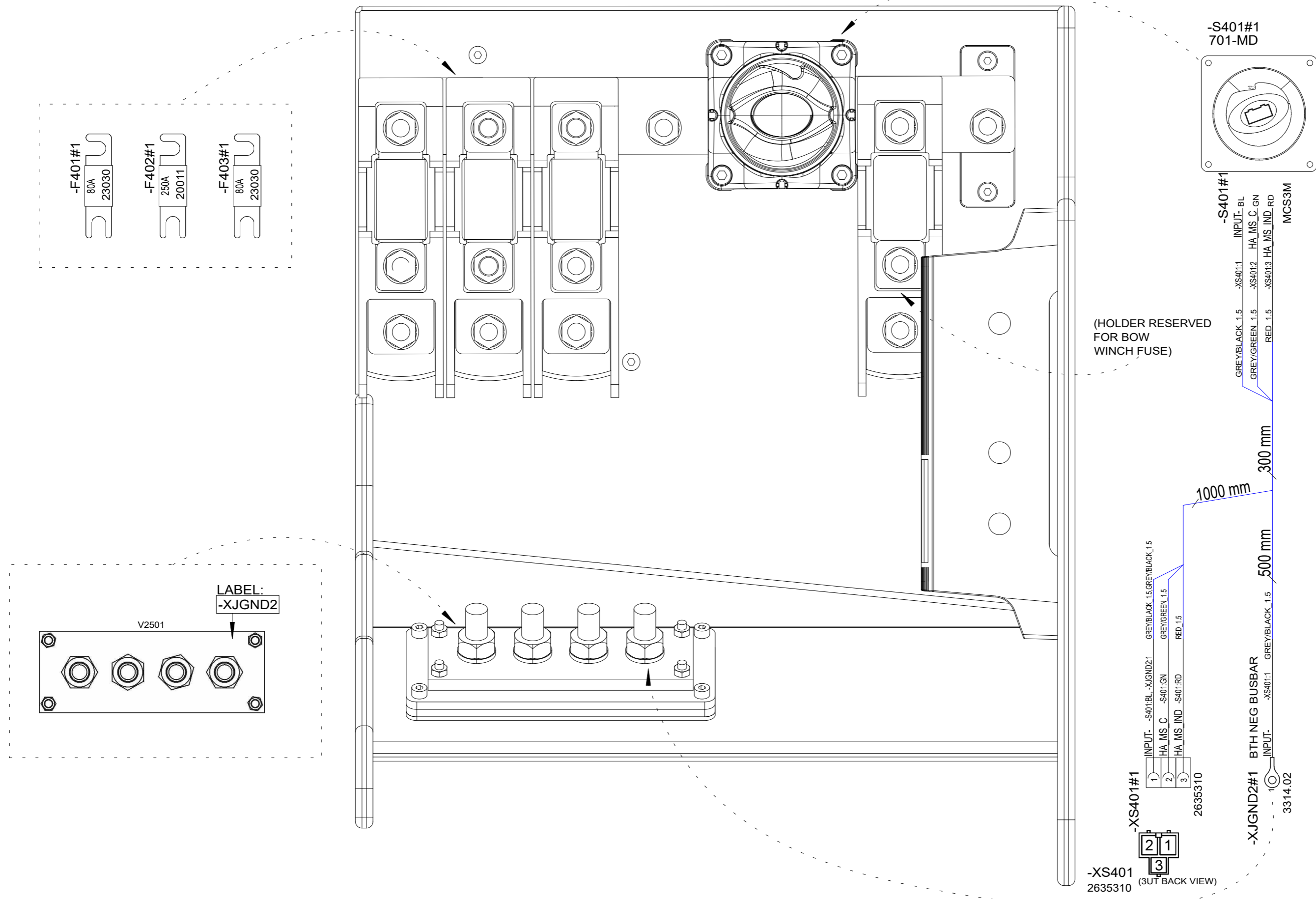

			Date	8.5.2023	Axopar		38688		2004468	
			Drawing by	PF	Boat		Product code		Project ID	
			Sheet rev.	1	28 MK3		Sub-product code		HL	
Date of modification			Modified by		Boat model		Title		Loc	
1	2	3	4	5	6	7	8	61/		Sheet

PANEL ASSEMBLY

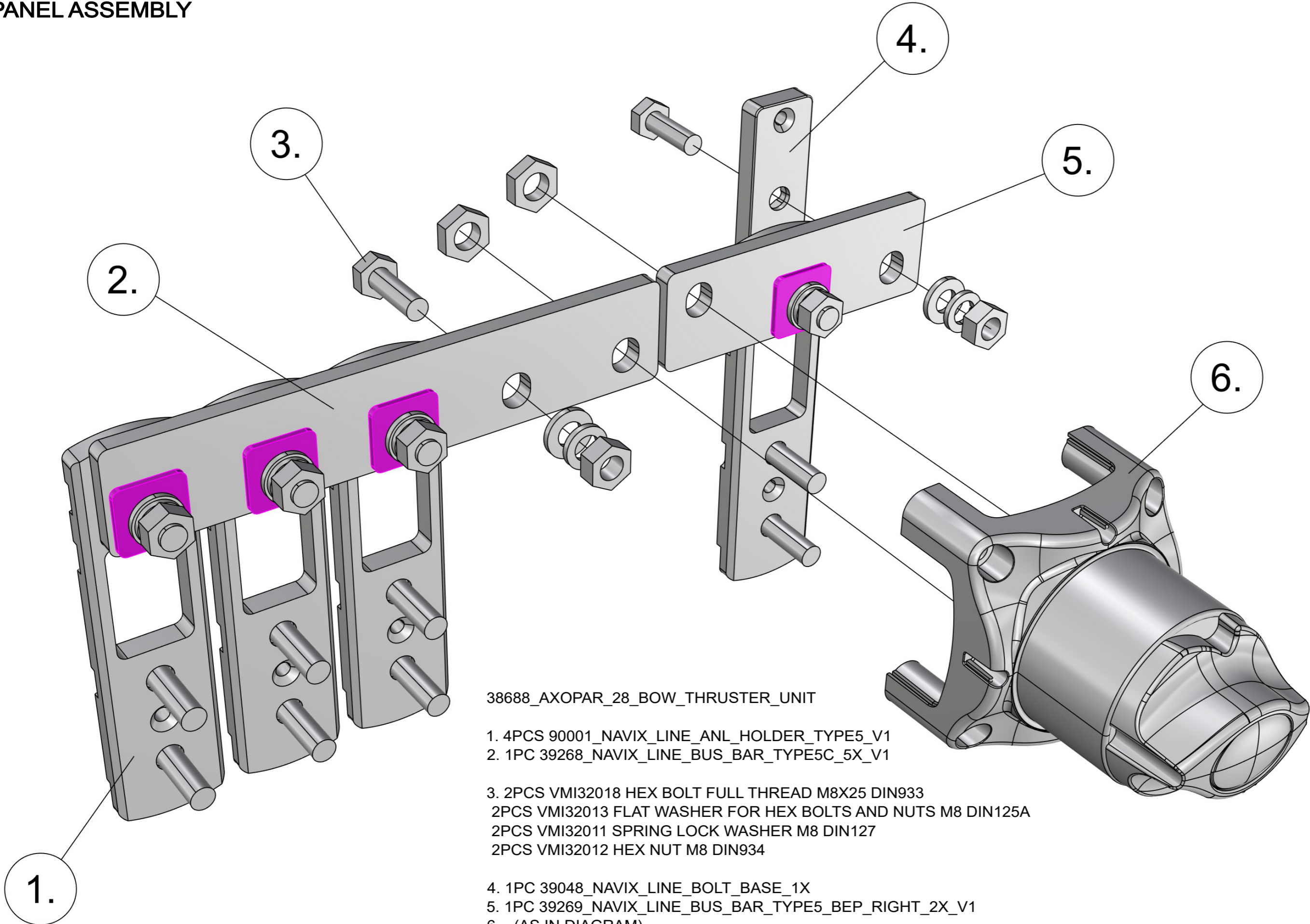

38688\_AXOPAR\_28\_BOW\_THRUSTER\_UNIT

- 1. 4PCS 90001\_NAVIX\_LINE\_ANL HOLDER\_TYPE5\_V1
- 2. 1PC 39268\_NAVIX\_LINE\_BUS\_BAR\_TYPE5C\_5X\_V1
- 3. 2PCS VMI32018 HEX BOLT FULL THREAD M8X25 DIN933  
 2PCS VMI32013 FLAT WASHER FOR HEX BOLTS AND NUTS M8 DIN125A  
 2PCS VMI32011 SPRING LOCK WASHER M8 DIN127  
 2PCS VMI32012 HEX NUT M8 DIN934
- 4. 1PC 39048\_NAVIX\_LINE\_BOLT\_BASE\_1X
- 5. 1PC 39269\_NAVIX\_LINE\_BUS\_BAR\_TYPE5\_BEP\_RIGHT\_2X\_V1
- 6. - (AS IN DIAGRAM)

			Date	1.6.2023	Axopar		38688		2004468	
			Drawing by	PF	Boat		Sub-product code		Project ID	
			Sheet rev.	1	28 MK3		BOW THRUSTER UNIT		HL	
Date of modification	Modified by	Description	Project rev.	A	Boat model		Title		Loc	
1			4		6		7		8	
									62 / Sheet	



Copyright by

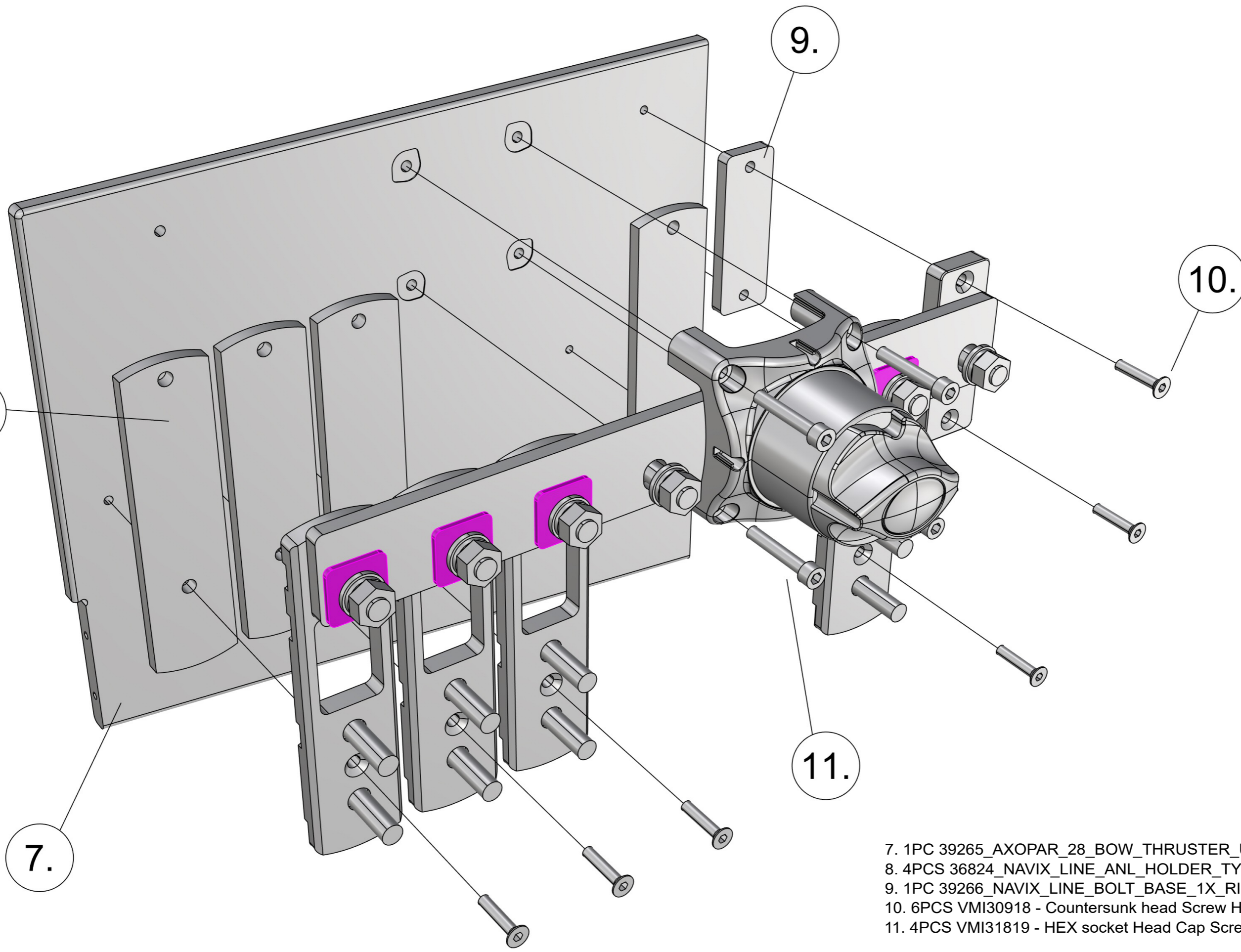

- 7. 1PC 39265\_AXOPAR\_28\_BOW\_THRUSTER\_UNIT\_BASE\_V1
- 8. 4PCS 36824\_NAVIX\_LINE\_ANL HOLDER\_TYPE\_SERIES\_RAISER\_V1
- 9. 1PC 39266\_NAVIX\_LINE\_BOLT\_BASE\_1X\_RISER\_V1
- 10. 6PCS VMI30918 - Countersunk head Screw HEX socket M4X20 DIN7991
- 11. 4PCS VMI31819 - HEX socket Head Cap Screw M5X30 DIN912

			Date	1.6.2023	Axopar		38688		2004468	
			Drawing by	PF	Boat		Sub-product code		Project ID	
			Sheet rev.	1	28 MK3		BOW THRUSTER UNIT		HL	
Date of modification	Modified by	Description	Project rev.	A	Boat model		Title		Loc	
1			4		5	6	7		8	63 / Sheet



14.

15.

16.

13.

12.

APPLY THIN LAYER OF 21119 - MS-Polymer, Black TO SHOWN SURFACES BEFORE FASTENING BOLTS

- 12. 1PC 39263\_AXOPAR\_28\_BOW\_THRUSTER\_UNIT\_SIDE\_WALL\_2\_V1
- 13. 9PCS VMI30918 - Countersunk head Screw HEX socket M4X20 DIN7991
- 14. 2PCS VMI30918 - Countersunk head Screw HEX socket M4X20 DIN7991  
2PCS VMI35429 - Extension Bolt M4 L-70
- 15. 1PC 39262\_AXOPAR\_28\_BOW\_THRUSTER\_UNIT\_SIDE\_WALL\_1\_V1
- 16. 1PC 39264\_AXOPAR\_28\_BOW\_THRUSTER\_UNIT\_BOTTOM\_V1

			Date	1.6.2023	Axopar		38688		2004468	
			Drawing by	PF	Boat		Product code		Project ID	
			Sheet rev.	1	28 MK3		BOW THRUSTER UNIT		HL	
Date of modification	Modified by	Description	Project rev.	A	Copyright by	Boat model	Title	Loc	64 / Sheet	
1	2	3	4	5	6	7	8			

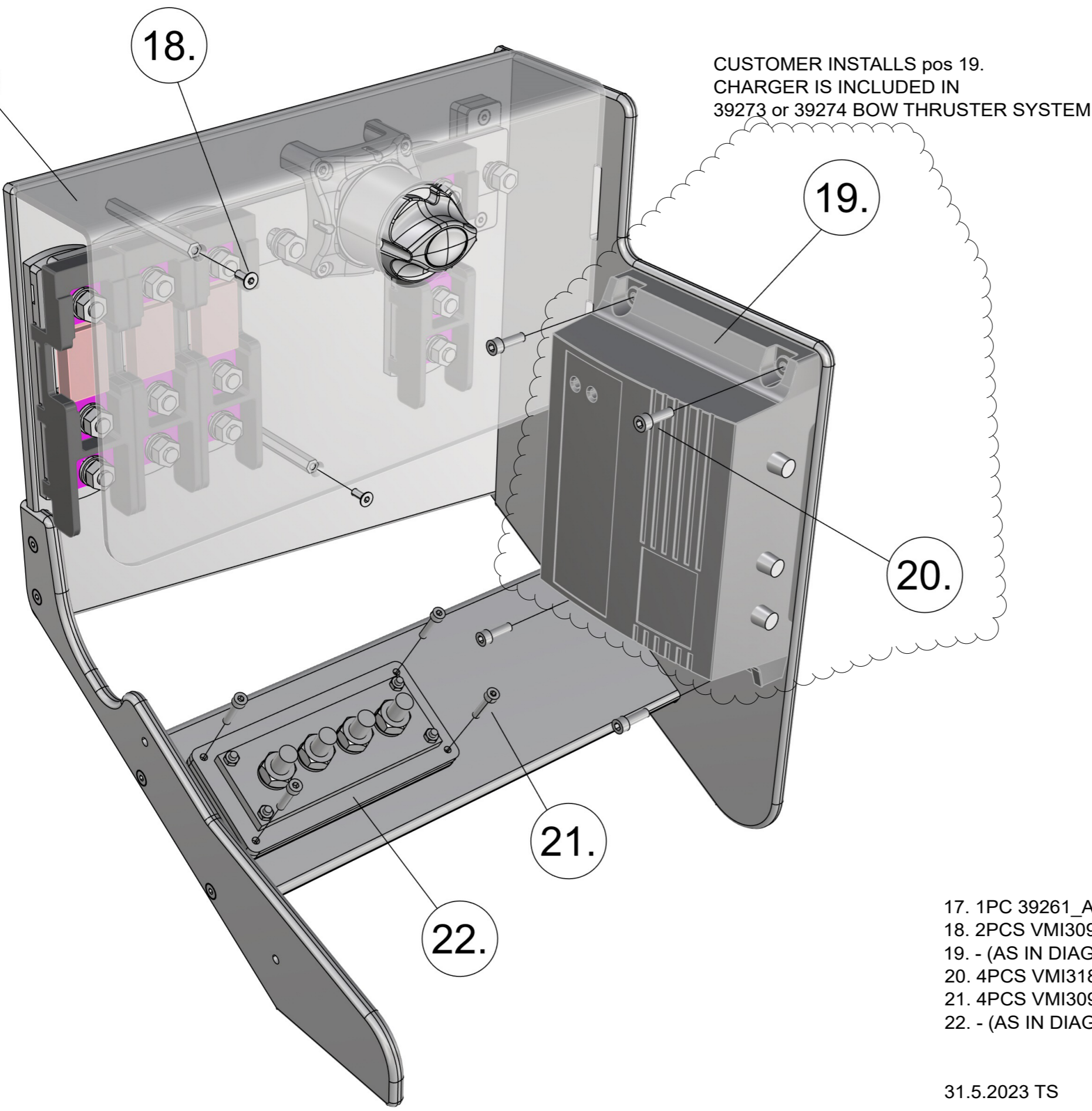

CUSTOMER INSTALLS pos 19.  
CHARGER IS INCLUDED IN  
39273 or 39274 BOW THRUSTER SYSTEM

- 17. 1PC 39261\_AXOPAR\_28\_BOW\_THRUSTER\_UNIT\_COVER\_V1
- 18. 2PCS VMI30914 COUNTERSUNK HEAD SCREW HEX SOCKET M4X10 DIN7991
- 19. - (AS IN DIAGRAM)
- 20. 4PCS VMI31817 - HEX socket Head Cap Screw M5X16 DIN912
- 21. 4PCS VMI30946 - HEX socket Head Cap Screw M4X20 DIN912
- 22. - (AS IN DIAGRAM)

31.5.2023 TS

			Date	1.6.2023	Axopar		38688		2004468	
			Drawing by	PF	Boat		Sub-product code		Product code	
			Sheet rev.	1	28 MK3		BOW THRUSTER UNIT		HL	
Date of modification	Modified by	Description	Project rev.	A	Copyright by	Boat model	Title	Loc	65 / Sheet	
1	2	3	4	5	6	7	8	8		

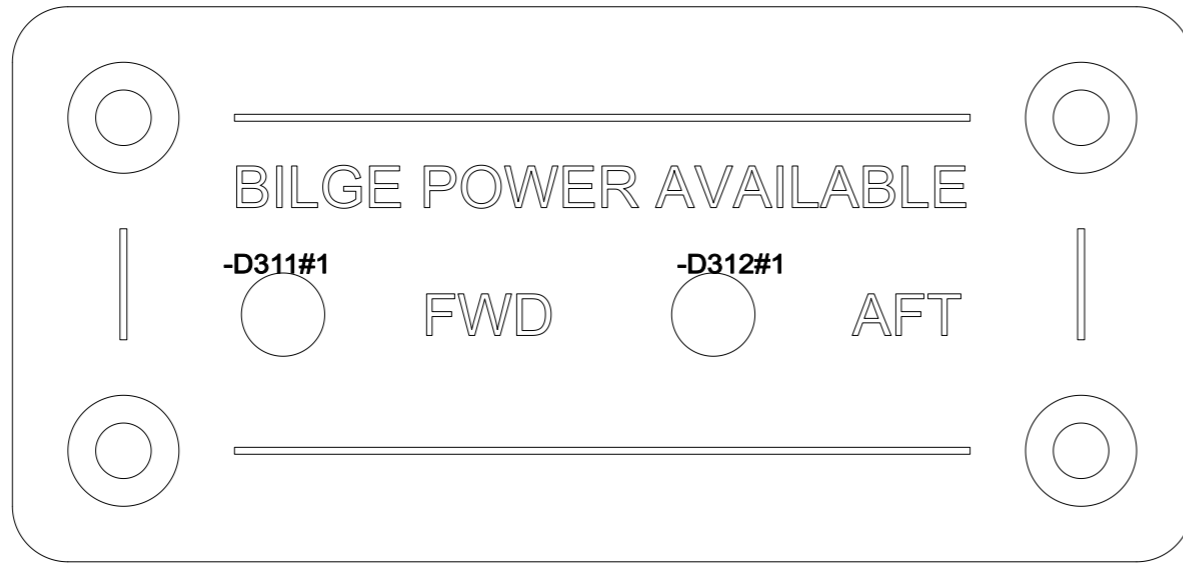

-D311#1  
12977



BILGE POWER AVAIL FWD

RED 1.5 -X.D3:1 BPF\_AUTO

YELLOW 1.5 -X.D3:3 INPUT-

100 mm

-D312#1  
12977



BILGE POWER AVAIL AFT

RED 1.5 -X.D3:2 BPA\_AUTO

YELLOW 1.5 -X.D3:3 INPUT-

100 mm

1400 mm

SWITCH PANEL -X.D3#1

RED 1.5 -D311+ BPF\_AUTO  
RED 1.5 -D312+ BPA\_AUTO  
YELLOW 1.5, YELLOW 1.5 -D312-, -D311- INPUT-



-X.D3  
2634310 (3NT BACK VIEW)

2634310

			Date	22.5.2023	Axopar		38693		2004468	
			Drawing by	PF	Boat		Sub-product code		Project ID	
			Sheet rev.	1	28 MK3		BILGE POWER AVAILABILITY PANEL		HL	
Date of modification	Modified by	Description	Project rev.	A	Copyright by	Boat model	Title	Loc	66 / Sheet	
1	2	3	4	5	6	7	8			



38693\_AXOPAR\_28\_BILGE\_POWER\_AVAILABILITY\_PANEL

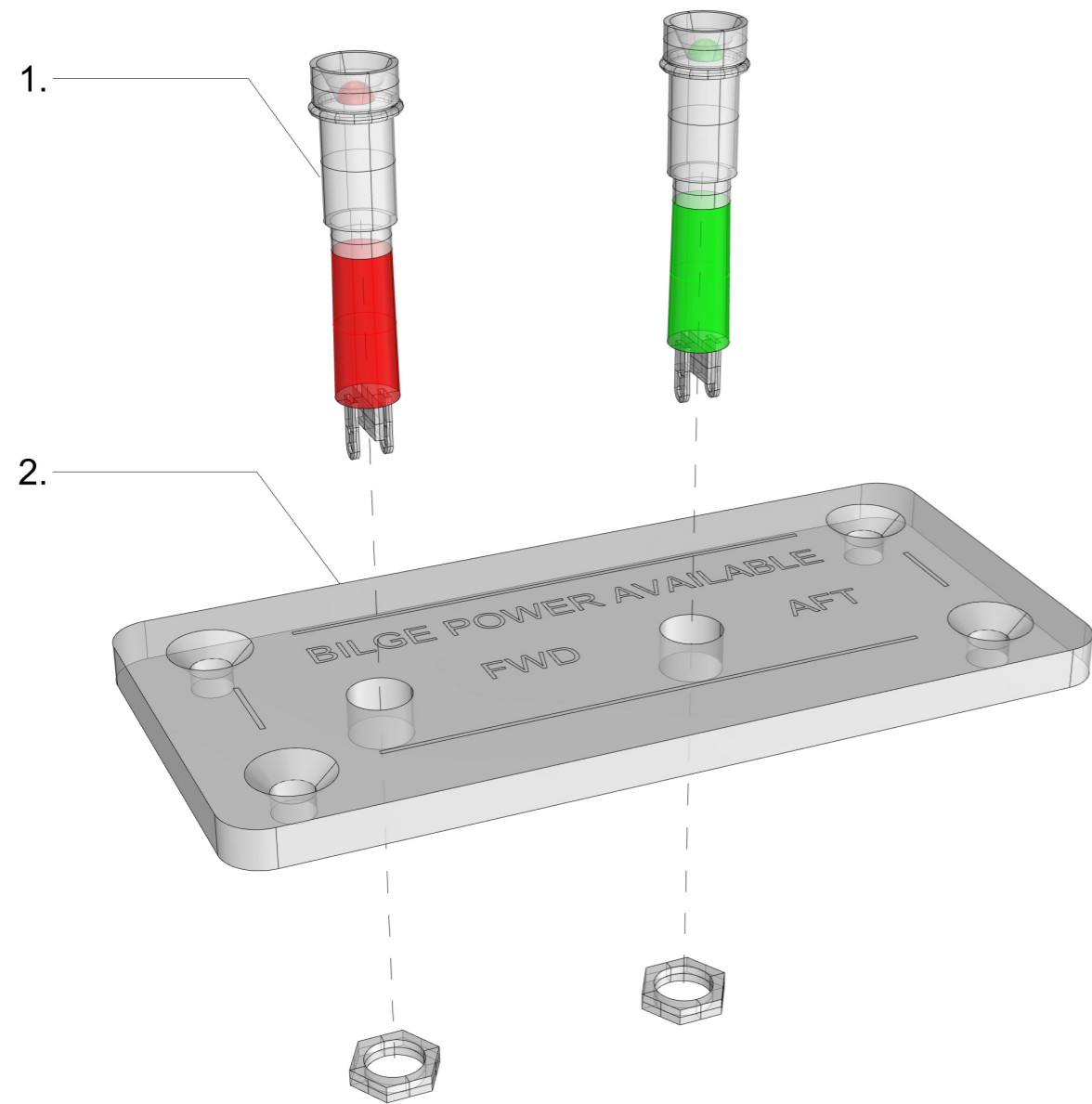

38693\_AXOPAR\_28\_BILGE\_POWER\_AVAILABILITY\_PANEL

1. 2 pcs Led Indicator ø3/6mm, 12V, Chrome frame (as in diagram)

2. 1 pc 39184\_AXOPAR\_28\_BILGE\_POWER\_AVAILABILITY\_PANEL\_(WOC)\_V1

22.05.2023 / TE ( project 2004468 )

			Date	22.5.2023	Axopar		38693		2004468	
			Drawing by	PF	Boat		Sub-product code		Product code	
			Sheet rev.	1	28 MK3		BILGE POWER AVAILABILITY PANEL		HL	
Date of modification	Modified by	Description	Project rev.	A	Copyright by	Boat model	Title	Loc	67 / Sheet	
1		2	3	4	5	6	7		8	

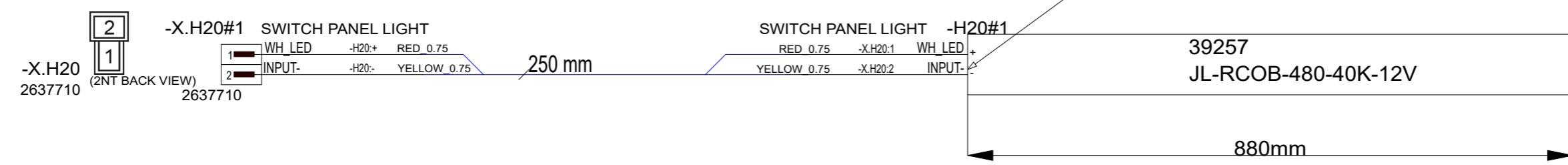
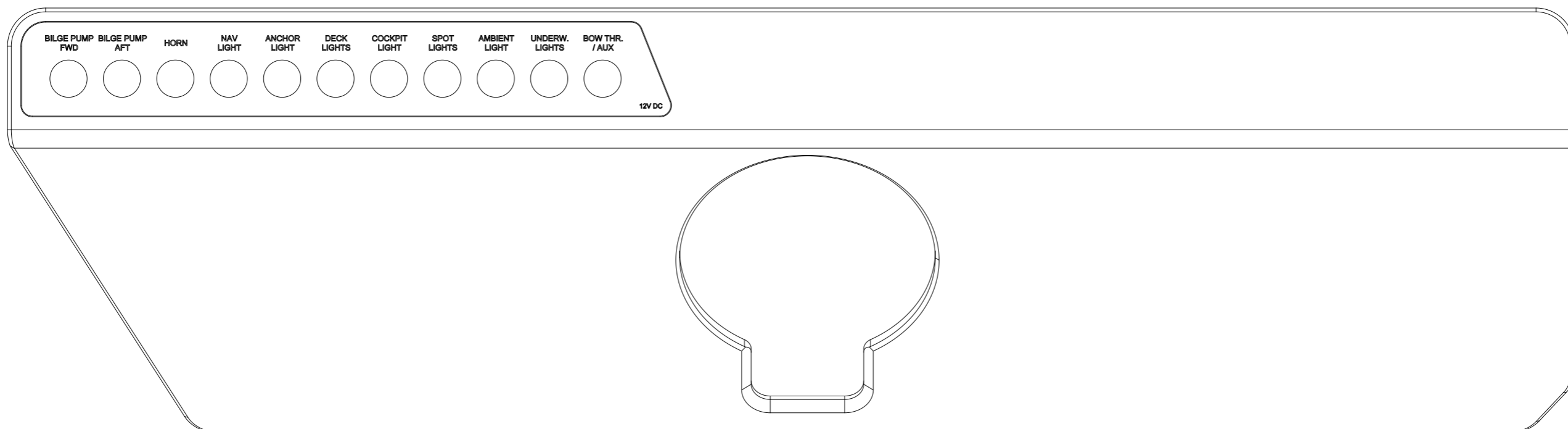

			Date	29.5.2023	Axopar		39236		2004468	
			Drawing by	PF	Boat		Product code		Project ID	
			Sheet rev.	1	28 MK3		Sub-product code		HL	
Date of modification	Modified by	Description	Project rev.	A	Copyright by	Boat model	Title		Loc	68 / Sheet
1	2	3	4	5	6	7	8			

# 39236\_AXOPAR\_28\_SWITCH\_PANEL\_EXTENDED

39236\_AXOPAR\_28\_SWITCH\_PANEL\_EXTENDED

- 1. 11PCS HALO SWITCH (AS IN DIAGRAM)
- 2. 1PC 39239\_AXOPAR\_28\_SWITCH\_PANEL\_INSERT\_PORT
- 3. 1PC 39240\_AXOPAR\_28\_SWITCH\_PANEL\_EXT\_BASE
- 4. 11PCS HALO SWITCH NUT
- 5. 1PC LED (AS IN DIAGRAM)
- 6. 1PC 39241\_AXOPAR\_28\_SWITCH\_PANEL\_EXT\_COVER
- 7. 6PCS VMI30912 -  
Countersunk Screw HEX socket head M4X6 DIN7991  
DO NOT OVER TIGHTEN

01.06.2023 / TE (2004468)

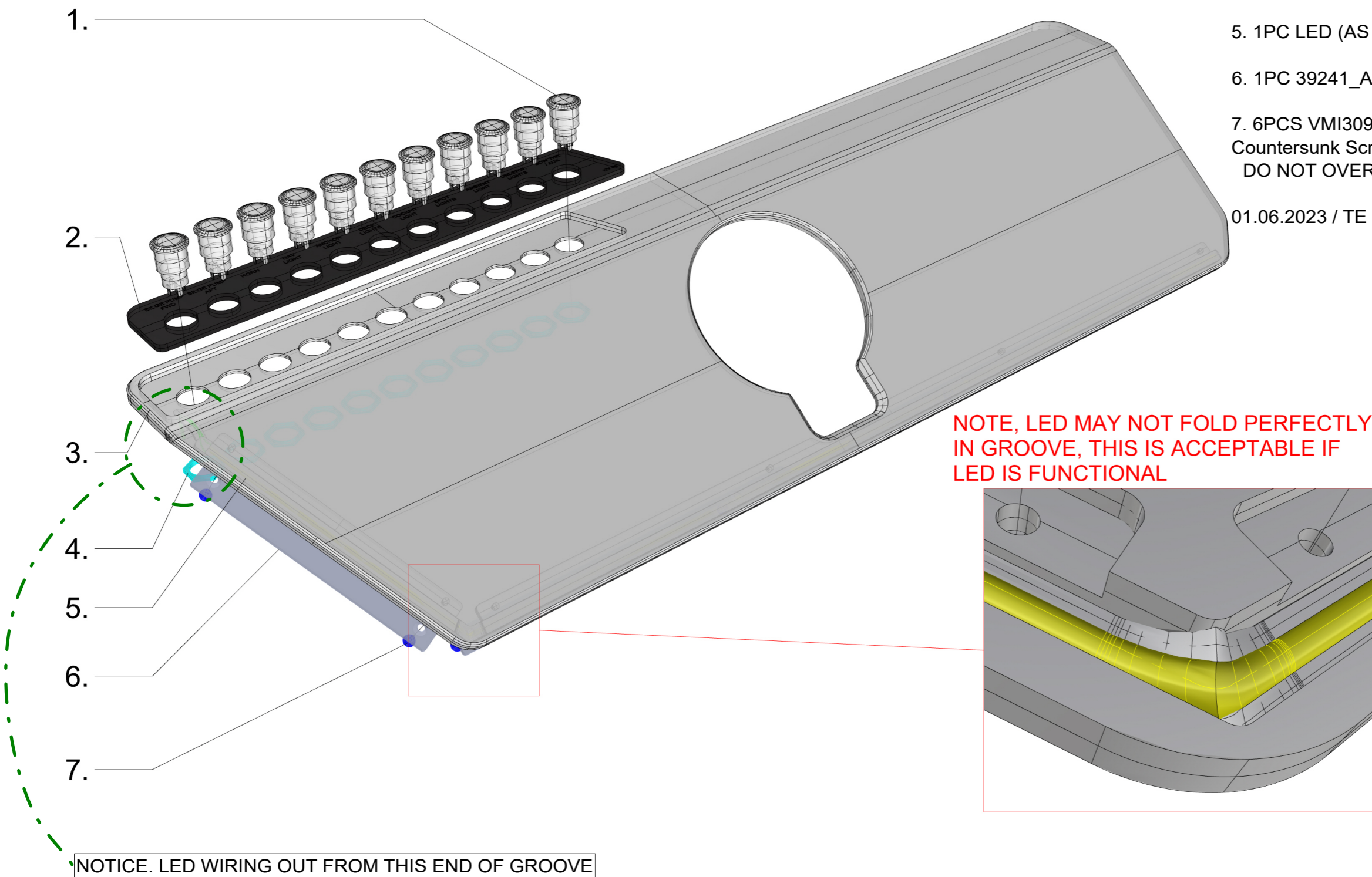

NOTE, LED MAY NOT FOLD PERFECTLY IN GROOVE, THIS IS ACCEPTABLE IF LED IS FUNCTIONAL

NOTICE. LED WIRING OUT FROM THIS END OF GROOVE

			Date	30.5.2023	Axopar		39236		2004468	
			Drawing by	PF	Boat		Product code		Project ID	
			Sheet rev.	1	28 MK3		SWITCH PANEL EXTENDED		HL	
Date of modification	Modified by	Description	Project rev.	A	Boat model	Title	Loc		69 / Sheet	
1		2	3	4	5	6	7	8		



Copyright by

# 12 Appendix IV: AIS Decontamination – North America

According to

ABYC T-32 Design and Construction in Consideration of Aquatic Invasive Species 7/21

© 2021 American Boat & Yacht Council, Inc

# Table of Contents

1 Decontamination criteria based on UMPS III, Table 3.....	3
2 Example of AIS Owner's Manual Information.....	4
3 Additional boat-specific recommendations.....	6

# 1 Decontamination criteria based on UMPS III, Table 3

The table is a summary of scientific research indicating the lethal water temperature at point of contact and duration for decontamination. Information is grouped by the location of the boat that is targeted and the life form of Dreissenid mussel targeted (e.g., adult mussel or veliger). Please refer to the *Student Training Curriculum for Watercraft Inspectors and Decontaminators to Prevent and Contain the Spread of Aquatic Invasive Species in the USA* for complete step by step procedures.

	Boat part/ location	Water temperature	Duration <sup>1)</sup> (sec)	Type of application	Target life stage
<b>Exterior</b>	Hull	140°F	10	High pressure spray <sup>2)</sup>	Adult
	Trailer	140°F	70	Low pressure spray <sup>3)</sup>	Adult
	PFDs, anchor, paddle	140°F	10	Low pressure spray	Adult or Veliger
<b>Propulsion system</b>	Gimbal	140°F	132	Low pressure spray	Adult
	Engine	140°F <sup>5), 6)</sup>	See note <sup>7)</sup> .	Flush <sup>6)</sup>	Veliger
<b>Interior</b>	Ballast tanks	120°F	130	Low risk – Flush <sup>4)</sup>	Veliger
				High risk – Fill and flush	
	Live well/bait well	120°F	130	Low pressure spray or flush	Veliger
	Bilge	120°F	130	Flush or low pressure spray	Veliger

1) The times listed are the minimum times necessary to achieve mortality.

2) High pressure = 3000 psi.

3) Low pressure = using the pressure from the decontamination unit with no nozzle, not to exceed 60 psi (essentially a garden hose flow).

4) Flush = adding water to a compartment of a boat to treat or force the water out.

5) These temperatures denote the exit temperature (i.e., temperature of water exiting the boat not exiting the wand or flush attachment).

6) When flushing engines with a dedicated connection (not mufflers), the pressure should be limited to less than 60 psi to prevent internal engine damage. The maximum input temperature during flushing should not exceed 140°F.

7) *NOTE: Engine flushing relies on the exit temperature as a guideline for decontamination duration.*

## 2 Example of AIS Owner's Manual Information

### Aquatic invasive species

Aquatic invasive species (AIS) are plants and animals that occur in waters in which they are not native and whose introduction causes or is likely to cause economic or environmental damage or harm to human health. AIS have a negative impact on the waterway, its native species, and recreational and commercial uses of the waterway.

As responsible boaters and citizens, each boat owner should do their part to prevent the spread of these aquatichitchhikers. In many cases, it is also required by law. Check local regulations for any waterway where you will boat.

After each boating trip, follow these three simple steps before you leave the water access to stop the spread of AIS: Clean, Drain, and Dry. This is the boater's way to help protect the environment from the damage that AIS can cause.



### Clean

Inspect and remove all aquatic plants, animals, mud, and debris from the boat, engine, trailer, anchor, and any watersports equipment.

- Rinse, scrub or wash, as appropriate, away from storm drains, ditches, or waterways.
- Rinse watercraft, trailer, and equipment with hot water, when possible.
- Flush motor according to owner's manual.

### Drain

Completely drain all water from the boat and its compartments, including but not limited to the bilge, wells, lockers, ballast tanks or bags, bait containers, engines, and outdrives.

### Dry

Allow the boat to completely dry before visiting any other bodies of water.

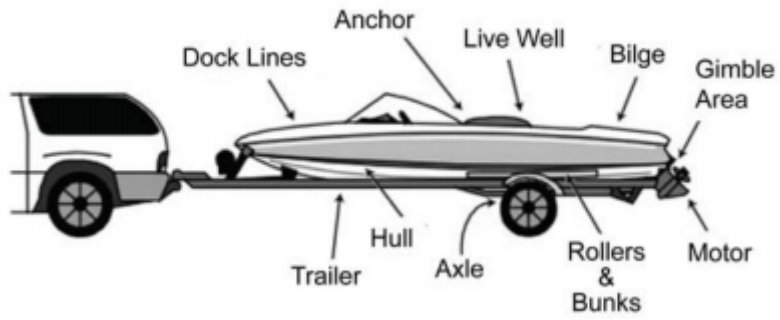

*NOTE: Some localities may require inspection or decontamination before and/or after launching. Check state and local laws and regulations for requirements prior to traveling to go boating.*



## 3 Additional boat-specific recommendations

### Nonmotorized watercraft

Canoes, rafts, kayaks, rowboats, paddleboats, inflatables, sculls, and other nonmotorized recreational watercraft also require proper treatment.

- **Clean** straps, gear, paddles, floats, ropes, anchors, dip nets, and trailer before leaving the water body.
- **Dry** everything completely between each use and before storing.
- **Wear** quick-dry footwear or bring a second pair of footwear with you when portaging between waterbodies.

### Sailboats

- **Clean** centerboard, bilge board, wells, rudderpost, trailer, and other equipment before leaving the water body.
- **Drain** water from boat, motor, bilge, ballast, wells, and portable bait containers before leaving the water body.

### Motorized watercraft

- **Inspect** and **clean** motor or engine, including the gimbal area; trailer, including axles, bunkers, and rollers; anchors; dock lines; and equipment before leaving the water body.
- **Drain** live wells, bait containers, ballast and bilge tanks, and engine cooling systems.

### Jet boats and personal watercraft (PWCs)

- **Inspect** and **clean** hull, trailer, intake grate, and steering nozzle, etc.
- **Clean** hull, trailer, intake grate, and steering nozzle, etc before leaving the water access.
- **Run** engine 5-10 sec to blow out excess water and vegetation from internal drive before leaving the waterbody.

# 13 Appendix V: Strapping and transport

REVISIONS			
REV.	DESCRIPTION	DATE	APPROVED

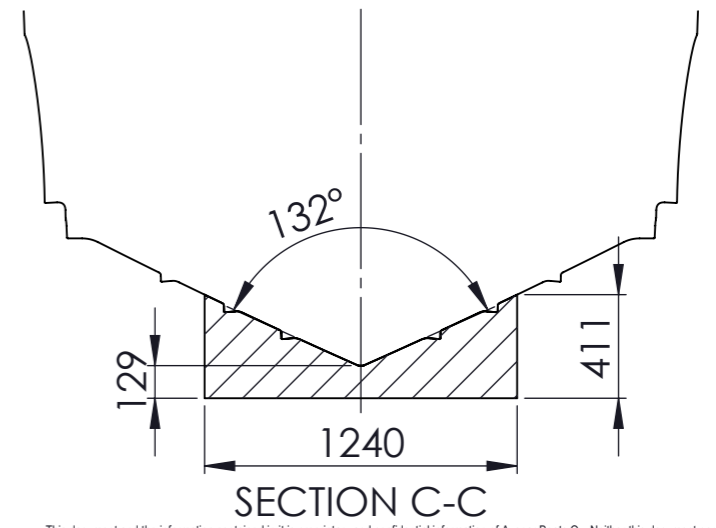
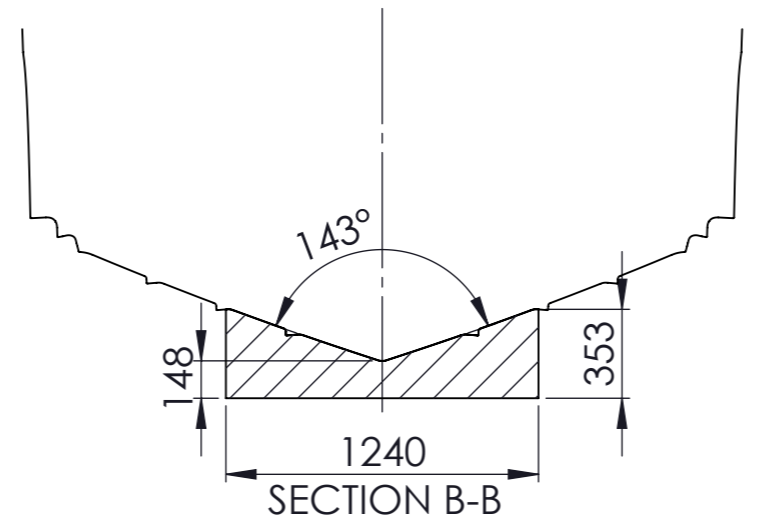
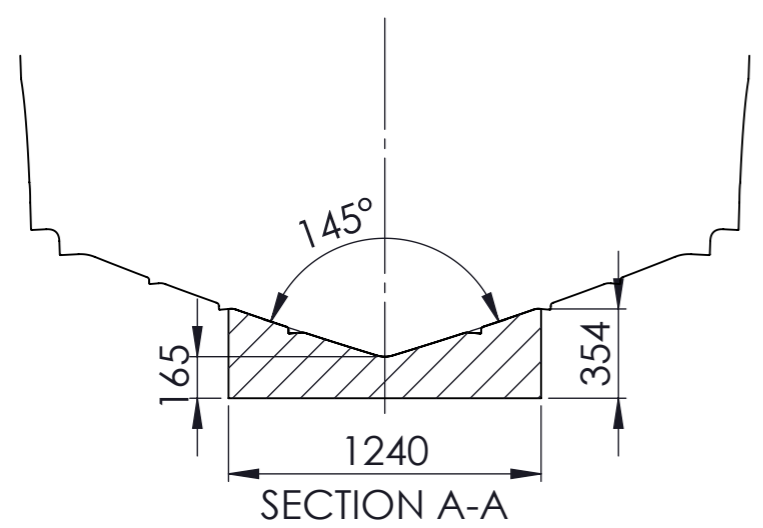
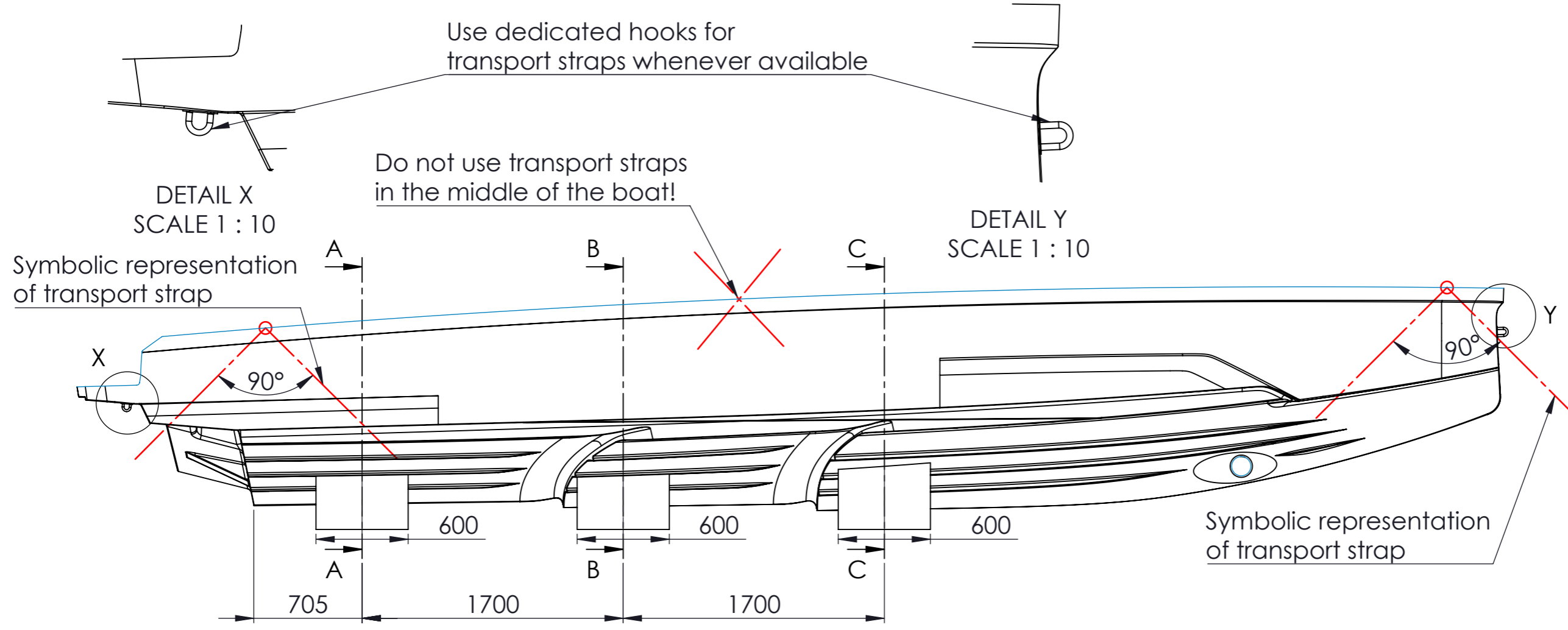

**NOTE:**  
 1. Material of cradles: Foam.  
 2. For transporting and securing the boat, use transport straps only in the indicated places (aft and bow side).

This document and the information contained in it is proprietary and confidential information of Axopar Boats Oy. Neither this document nor any of the information contained herein may be reproduced, disclosed to others, or used for any purpose other than for the purpose it has been provided without the prior written permission of Axopar Boats Oy.

<b>AXOPAR</b>		ITEM	REV
BOAT MODEL AX28 MK3		DRAWING	A
MODEL YEAR 2023		REV	0
BY	DATE	DESCRIPTION	SCALE
CREATED ANTMIH	03.10.2023	Strapping and Transport	1:30
CHECKED L.C.	03.10.2023	TECHNICAL DESCRIPTION	PAGE
ACCEPTED AJU	08.11.2023	Manufacturing specification	1 / 1

